



STAR WARS



75222



**“I’VE JUST MADE A DEAL THAT’LL KEEP THE
EMPIRE OUT OF HERE FOREVER.”**

– Lando Calrissian™



Design Director: Jens Kronvold Frederiksen

ABOUT THE LEGO® STAR WARS™ DESIGN TEAM

LEGO® *Star Wars* started in 1999 and we have made new models for the product line every year since then. The LEGO *Star Wars* design team consists of eleven model designers and four graphic designers. The team is a mix of brand new designers with new fresh ideas, and experienced LEGO *Star Wars* designers with many models under their belts.

This is an ideal team for creating new, innovative LEGO *Star Wars* models, as well as revising and improving previous LEGO versions of classic and iconic *Star Wars* ships. The focus of our main LEGO *Star Wars* product line is to make cool, fun, and inspiring LEGO *Star Wars* models for children.

For LEGO Direct, we have the opportunity to make even bigger, more challenging models with special attention to accuracy and details. These models are fun and exciting to develop, but also a huge challenge! We always do our very best, and hope you will enjoy building them.

Happy building!

Jens Kronvold Frederiksen
Design Director, LEGO® *Star Wars*™



Ralph McQuarrie © & ™ Lucasfilm Ltd.

ABOUT CLOUD CITY

The beautiful Cloud City, known for its aesthetics and luxury, was founded as a Tibanna gas mining colony. It has a population of several million tourists, workers and support staff all hovering over the gas giant, Bespin. The station floats 36,660 miles above Bespin's core, while its disk is approximately 10 miles in diameter. 3,600 repulsorlift engines and tractor beam generators keep the giant city floating above the planet. The city possesses 392 levels, which include platforms and rooms for residents and visitors. The top 50 levels of the city are used as a luxury resort, with famous casinos such as Yarith, Bespin and Pair O'Dice. Meanwhile, the lower levels are used as worker housing for those handling the mining and processing of Tibanna gas.

The Tibanna gas mining process is performed thanks to tractor beams emitted from the underside of the city, converging below the gas mine's reactor bulb to

create a funnel of energy that mines Tibanna gas from Bespin's lower atmosphere, at depths of more than 14,291 miles. The gas is forced up into an opening at the bottom of the bulb, where it travels up the reactor stalk and finally into one of several smaller reactor shafts, where it is filtered through a processing vane. Each vane maintains a carbon-freeze chamber, where Tibanna gas is mixed with carbonite for flash-freeze preservation. One of the chambers was famously used to freeze the smuggler Han Solo™ in carbonite after Imperial forces captured him.

A stay at Cloud City is a memorable but often expensive experience, with luxury resorts often charging as much as 5,000 Imperial credits per night. Popular tourist activities include gambling, cloud car sightseeing tours of the city and occasional tours of the local mining operations.

FACTS/SPECIFICATIONS

Cloud City

Population.....5.5 million
Location.....Bespin
Diameter.....10 miles
Primary function.....Tibanna gas mining and processing

Slave I

- Modified *Firespray-31*-class patrol and attack craft
- Originally piloted by Jango Fett, later by his son Boba Fett™
- Maximum speed of 621 miles per hour

Twin-Pod Cloud Car

- Designed and produced by Bespin Motors to patrol the skies surrounding Cloud City
- Kyromaster dual ion engine system
- Maximum speed of 932 miles per hour



© & ™ Lucasfilm Ltd.



© & ™ Lucasfilm Ltd.

MEET THE MODEL DESIGNER

Hans Burkhard Schlömer

What was the first step in recreating Cloud City as a LEGO® set?

One could say I started early! Years before it was even decided to develop a new Cloud City, I built a small-scale *Slave I*, Boba Fett's ship, with a later Bespin set in mind. As a LEGO *Star Wars* fan and collector myself, Cloud City was always at the top of my personal wish list, so I began thinking about different concepts early on. To me, *Slave I* belongs to Cloud City. Any play set just wouldn't feel complete without it.

Later in the design process I realized that I had to make room inside to store the block of carbonite with frozen Han Solo™—how could Boba Fett™ transport his bounty otherwise? This was quite a challenge with such a small model!

What reference materials did you use?

The main source of reference and inspiration were screenshots from Episode V, *THE EMPIRE STRIKES BACK*. It is interesting to see how light conditions change on the movie set, which affects the colors of some areas. I believe it is early morning when our heroes arrive. Then the day goes by, and when they make their escape the sun is just setting. This was important to keep in mind when choosing colors for the landing platform, for example—I know it really is plain gray, but we never see it like this in the movie. This is why I went with warmer tan and dark tan colors for this area.



Hans Burkhard Schlömer

What is uniquely inspirational about the Cloud City setting?

To me as a designer, the movie's set design is simply amazing. It is a very subtle art deco style. There are so many little details to discover once one starts paying attention. I wanted to have those details in my set. All of them!

The mood and colors also change when moving from one area to the next. It is like a color code! While rooms and corridors initially are mostly white, open and airy, this quickly gives way to an oppressive dark red when entering the prison area. My favorite detail is the "menacing eyes" in the outer walls of the prison cells - light fixtures glowering at people walking by.

What was the most challenging part of the design process?

Cloud City was not a totally straight design process. Most of the interior has been there from the beginning in one form or another, but the overall concept has changed several times. One big challenge was how to tie all the rooms together in order to give the model shape. The four beams on top outlining the roof/outer shell of Cloud City do this job efficiently without blocking any of the play areas. The goal was to achieve a design language similar to our Death Star play set, just less brick-heavy and with all rooms arranged on one level.

What is your favorite feature of the set?

I actually have two favorite features! One is that the rooms are arranged in a logical way, allowing the whole storyline to be played out just like in the movie. The other is that there are two smaller vehicles with the set, one of them a twin-pod cloud car – a vehicle we haven't seen in LEGO® form for a very long time!

How is this set different from others you have done in the past?

Cloud City is certainly the biggest play set I have done so far. Designing it took me even longer than the UCS *Millennium Falcon*™!

Was there anything in the original design that didn't make it to the final design?

From the outside, Cloud City appears like a hovering mushroom. However, my design brief specifically requested a play set, and play sets need to have solid supports and be accessible. This means lifting the whole set far up on a stand and closing it off with covers was not an option. To achieve the quality we want to deliver, a solution with a platform closer to the ground was required. Aside from that, pretty much everything else I wanted to have in the set made it into the box!

What about the set might surprise builders?

The variety of different builds in this set may come as a surprise, albeit a pleasant one! For example, bag two gives you a wide variety of elements to build a detailed spacecraft. And with the following bag you get—bricks only! Big bricks, at that, to create the cross-shaped base of Cloud City. Overall, the building sequence is supposed to make sense, be interesting, and deliver a great building experience until the last bag. Enjoy your stay in the clouds!

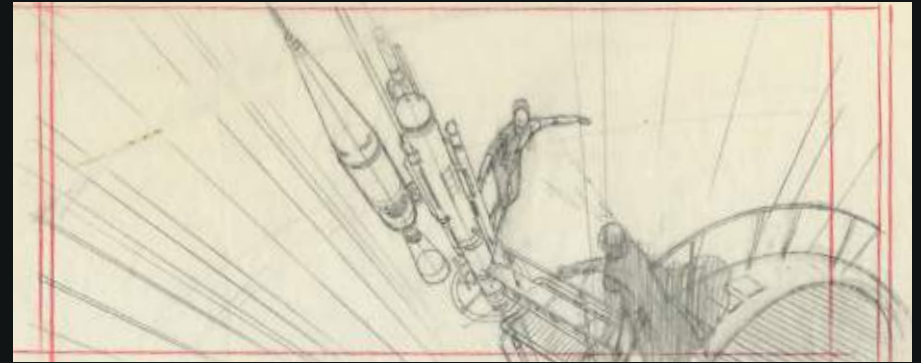

© & ™ Lucasfilm Ltd.



© & ™ Lucasfilm Ltd.

MEET THE GRAPHIC DESIGNER

Madison O'Neil

What is the first step in designing the minifigures?

The very first steps would be establishing which characters to include in the set and determining the design needs of those characters. Are any new elements needed, or are existing elements needed in new colors? How many printed elements are necessary? Do the characters require textiles? What are the best ways to create novelty and excitement in these classic characters? Once these questions are answered we can begin the more specific design tasks.

What kind of reference material did you use?

Cloud City is an iconic classic location, so reference material was easy to assemble. My favorite way to gather reference is to search through the film and take screenshots of the specific scenes or characters I need. I find that even after seeing the film countless times I still discover new details. My biggest surprise in this set was when I realized the inside of Lando's cape is stitched with an intricate pattern, a detail we were able to incorporate into his minifigure.

How did you approach conveying a character's personality in their design?

For minifigures, I find that the vast majority of the personality must come from the facial expressions. On the front side of a minifigure's head we will generally design a character with a slightly neutral expression, a gentle smile or light frown depending on who it is. It's on the back of the head where we push the expression further to capture another aspect of the character's personality or story. For example, Lando's big charming smile, or Luke's shock when he realizes (spoiler alert) that Darth Vader™ is his father.



Madison O'Neil

Even though minifigures are small, often they require a lot of detail. How did you approach incorporating detailed “costumes” and faces on such small figures?

There is a certain level of detail that is considered “LEGO® Star Wars DNA” and anything beyond that starts to fall away from our established design aesthetic. Design for minifigures becomes about prioritizing the most important and iconic aspects of the characters, while perhaps eliminating those details that might not translate well to the minifigure scale.

What was your favorite minifigure to design? What was the most difficult minifigure to design?

My favorite decorations in this set happen to also be the ones that were the most challenging to create. It was a tricky task to translate the pattern on Princess Leia's Cloud City dress down to minifigure scale, and the same goes for the repeating pattern inside Lando's cape. But, I feel that these details and new costumes are exciting additions to the LEGO Star Wars assortment and will get fans excited.



© & ™ Lucasfilm Ltd.



© & ™ Lucasfilm Ltd.

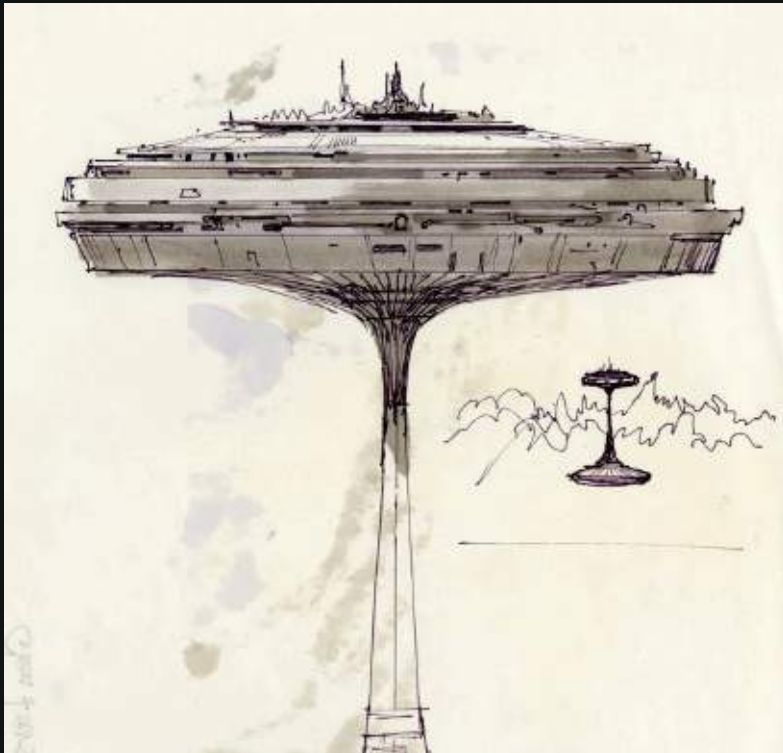

© & ™ Lucasfilm Ltd.

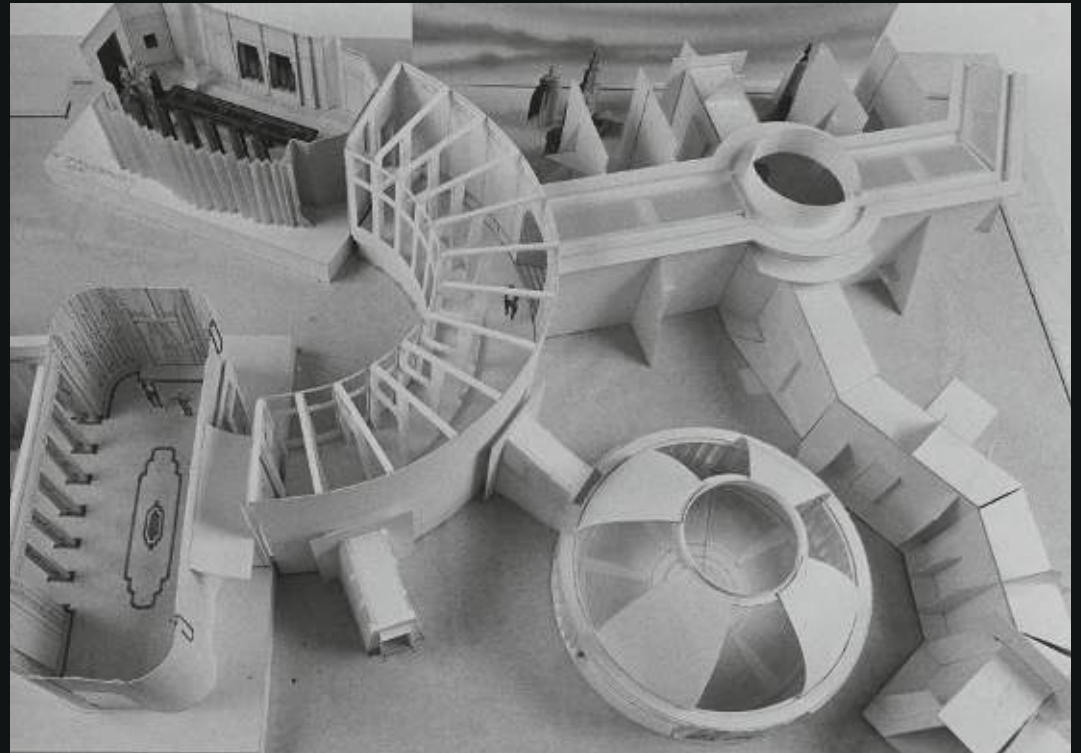

© & ™ Lucasfilm Ltd.



**« J'AI FAIT UN ARRANGEMENT QUI MAINTIENT
DÉFINITIVEMENT L'EMPIRE À L'ÉCART. »**

– Lando Calrissian™



Directeur du design : Jens Kronvold Frederiksen

À PROPOS DE L'ÉQUIPE DE DESIGN LEGO® STAR WARS™

L'aventure LEGO® *Star Wars* a commencé en 1999 et nous avons depuis conçu chaque année de nouveaux modèles pour cette gamme de produits. L'équipe de design LEGO *Star Wars* est composée de onze créateurs de modèles et de quatre graphistes. Elle regroupe de nouveaux designers avec des idées originales et des designers LEGO *Star Wars* expérimentés ayant de nombreux modèles à leur actif.

Il s'agit de l'équipe idéale pour créer de nouveaux modèles LEGO *Star Wars* innovants et pour améliorer les versions LEGO antérieures des célèbres vaisseaux cultes. L'objectif de notre gamme principale de produits LEGO *Star Wars* est de créer des modèles LEGO *Star Wars* cool, amusants et stimulants pour les enfants.

Pour LEGO Direct, nous avons la possibilité de créer des modèles encore plus grands et plus complexes, en prêtant une attention particulière à la précision et aux détails. Ces modèles sont amusants et fascinants à concevoir, mais ils constituent aussi un énorme défi ! Nous faisons toujours de notre mieux et nous espérons que vous apprécierez l'expérience de construction.

Bonne construction !

Jens Kronvold Frederiksen
Directeur du design, LEGO® *Star Wars*™



Ralph McQuarrie © & ™ Lucasfilm Ltd.

À PROPOS DE LA CITÉ DES NUAGES

La belle Cité des Nuages, réputée pour son esthétique et son luxe, a été fondée en tant que colonie minière produisant du gaz Tibanna. Elle a une population de plusieurs millions de touristes, de travailleurs et de personnel de soutien, planant tous sur Bespin, la planète gazeuse géante. La station flotte à 59 000 kilomètres au-dessus du centre de Bespin, tandis que son disque est d'environ 16,2 kilomètres de diamètre. 3 600 répulseurs et générateurs de rayons tracteurs permettent à la ville géante de flotter au-dessus de la planète. La ville possède 392 niveaux, qui comprennent des plates-formes et des pièces pour les résidents et les visiteurs. Les 50 premiers niveaux de la ville sont utilisés comme complexe touristique de luxe, avec des casinos célèbres tels que Yarith, Bespin et Pair O'Dice. Les niveaux inférieurs sont eux utilisés comme logements pour les travailleurs effectuant l'extraction et le traitement du gaz Tibanna.

Le processus d'extraction du gaz Tibanna est réalisé grâce à des rayons tracteurs émis depuis le dessous de la ville, convergeant sous le bulbe du réacteur de la mine de gaz pour

créer une cheminée d'énergie qui extrait le gaz Tibanna depuis l'atmosphère inférieure de Bespin, à des profondeurs de plus de 23 000 kilomètres. Le gaz est poussé vers le haut dans une ouverture au fond du bulbe, où il se déplace vers le haut de la tige de réacteur et finalement dans l'un des arbres de réacteur plus petits, où il est filtré par une aube de traitement. Chaque aube maintient une chambre de congélation carbonique, où le gaz Tibanna est mélangé avec de la carbonite pour une préservation en congélation instantanée. Une des chambres est célèbre pour avoir été utilisée pour congeler le contrebandier Han Solo™ dans la carbonite après que les forces impériales l'aient capturé.

Un séjour dans la Cité des Nuages est une expérience inoubliable mais souvent coûteuse, avec des complexes touristiques de luxe coûtant souvent plus de 5 000 crédits impériaux par nuit. Les activités touristiques populaires incluent le jeu, les visites guidées de la ville et les visites occasionnelles des opérations minières locales.

INFORMATIONS/CARACTÉRISTIQUES

Cité des Nuages

Population..... 5,5 millions
Lieu..... Bespin
Diamètre..... 16,2 kilomètres
Fonction primaire..... Extraction et transformation de gaz Tibanna

Slave I

- Vaisseau de patrouille et d'attaque *Firespray-31* modifié
- Piloté à l'origine par Jango Fett, plus tard par son fils Boba Fett™
- Vitesse maximale de 1 000 km/h

Voiture des nuages à doubles capsules

- Conçue et produite par Bespin Motors pour patrouiller les lieux entourant la Cité des Nuages
- Système de propulseur ionique double Kyromaster
- Vitesse maximale de 1 500 km/h



© & ™ Lucasfilm Ltd.



© & ™ Lucasfilm Ltd.

RENCONTRE AVEC LE DESIGNER DU MODÈLE

Hans Burkhard Schlömer

Quelle a été la première étape de la recréation de la Cité des Nuages en tant qu'ensemble LEGO® ?

On pourrait dire que j'ai commencé tôt ! Des années avant même de décider de concevoir une nouvelle Cité des Nuages, j'ai construit une version à petite échelle du *Slave I*, le vaisseau de Boba Fett™, avec l'idée d'un ensemble Bospin ultérieur. En tant que fan et collectionneur de LEGO *Star Wars*, la Cité des Nuages a toujours été au sommet de ma liste de souhaits personnels, alors j'ai commencé à penser à différents concepts dès le début. Pour moi, le *Slave I* appartient à la Cité des Nuages. Tout ensemble ne semblerait pas complet sans cela.

Plus tard dans le processus de conception, j'ai réalisé que je devais faire de la place à l'intérieur pour le bloc de carbonite dans lequel Han Solo™ est congelé : comment Boba Fett pourrait-il transporter sa prime autrement ? C'était un vrai défi avec un si petit modèle !

Quels documents de référence avez-vous utilisés ?

La principale source de référence et d'inspiration a été des captures d'écran de l'Épisode V, *L'EMPIRE CONTRE-ATTAQUE*. Il est intéressant de voir comment les conditions de lumière changent sur le plateau du film, ce qui affecte les couleurs de certaines zones. Je crois qu'il est tôt le matin quand nos héros arrivent. Puis le jour passe, et quand ils s'évadent, le soleil se couche. Il était important d'y penser lors du choix des couleurs pour la plate-forme d'atterrissage, par exemple. Je sais qu'en réalité elle est grise, mais nous ne la voyons jamais comme ça dans le film. C'est pourquoi j'ai choisi des couleurs plus chaudes, beige et beige foncé, pour cette zone.



Hans Burkhard Schlömer

Qu'est-ce qui est particulièrement inspirant sur le décor de la Cité des Nuages ?

Pour moi, en tant que designer, la conception du décor du film est tout simplement incroyable. C'est un style Art déco très subtil. Il y a tellement de petits détails à découvrir une fois que l'on commence à y faire attention. Je voulais avoir ces détails dans mon ensemble. Tous !

L'ambiance et les couleurs changent également en passant d'une zone à l'autre. C'est comme un code de couleurs ! Alors que les pièces et les couloirs sont d'abord principalement blancs, ouverts et aérés, cela cède rapidement la place à un oppressant rouge foncé en entrant dans la zone carcérale. Mes détails préférés sont les « yeux menaçants » dans les murs extérieurs des cellules de la prison - des lumières terribles regardant d'un air méchant les gens qui marchent.

Quelle a été la partie la plus complexe dans la création de cet ensemble ?

Le processus de conception de la Cité des Nuages n'était pas aisé. La plus grande partie de l'intérieur était là dès le début sous une forme ou une autre, mais le concept global a changé à plusieurs reprises. Un grand défi était de savoir comment attacher toutes les pièces ensemble afin de donner sa forme au modèle. Les quatre poutres sur le dessus décrivant le toit/la coquille extérieure de la Cité des Nuages font ce travail efficacement sans bloquer aucune zone de jeu. L'objectif était de parvenir à un langage de conception similaire à notre ensemble de l'Étoile de la Mort, avec moins de briques et avec toutes les pièces disposées sur un niveau.

Quelle est votre caractéristique préférée de l'ensemble ?

En fait, j'ai deux caractéristiques préférées ! L'une est que les pièces sont arrangées d'une manière logique, permettant à l'histoire entière d'être jouée comme dans le film. L'autre est qu'il y a deux véhicules plus petits avec l'ensemble, l'un d'eux une voiture des nuages à doubles capsules, un véhicule que nous n'avons pas vu sous forme LEGO® depuis très longtemps !

En quoi cet ensemble est-il différent des autres que vous avez faits dans le passé ?

La Cité des Nuages est certainement le plus grand ensemble que j'ai fait jusqu'à présent. Concevoir cet ensemble m'a pris encore plus de temps que le *Millennium Falcon*™ de la série de collection suprême !

Y a-t-il quelque chose dans la conception originale qui a été éliminé de la conception finale ?

De l'extérieur, la Cité des Nuages ressemble à un champignon en vol stationnaire. Cependant, mon énoncé de conception demandait spécifiquement un ensemble de jeu, et les ensembles de jeu doivent avoir des supports solides et être accessibles. Cela signifie qu'élever l'ensemble sur un support et le fermer avec des couvercles n'était pas une option. Pour atteindre la qualité que nous voulons offrir, une solution avec une plate-forme plus proche du sol était requise. Mis à part cela, à peu près tout ce que je voulais avoir dans l'ensemble se trouve dans la boîte !

Qu'est-ce qui pourrait étonner les constructeurs dans cet ensemble ?

La variété des différentes constructions dans cet ensemble peut être une surprise, mais agréable ! Par exemple, le sac deux vous donne une grande variété d'éléments pour construire un vaisseau spatial détaillé. Et avec le sac suivant, vous obtenez... seulement des briques ! De grandes briques, pour créer la base en forme de croix de la Cité des Nuages. Dans l'ensemble, la séquence de construction est censée avoir du sens, être intéressante, et livrer une grande expérience de construction jusqu'au dernier sac. Profitez de votre séjour dans les nuages !

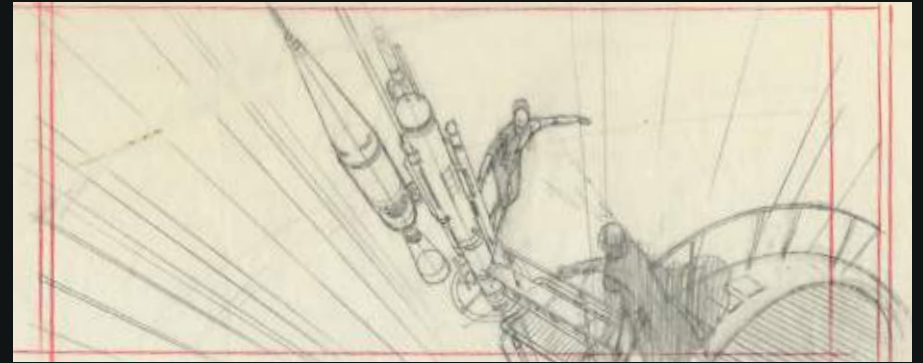

© & ™ Lucasfilm Ltd.

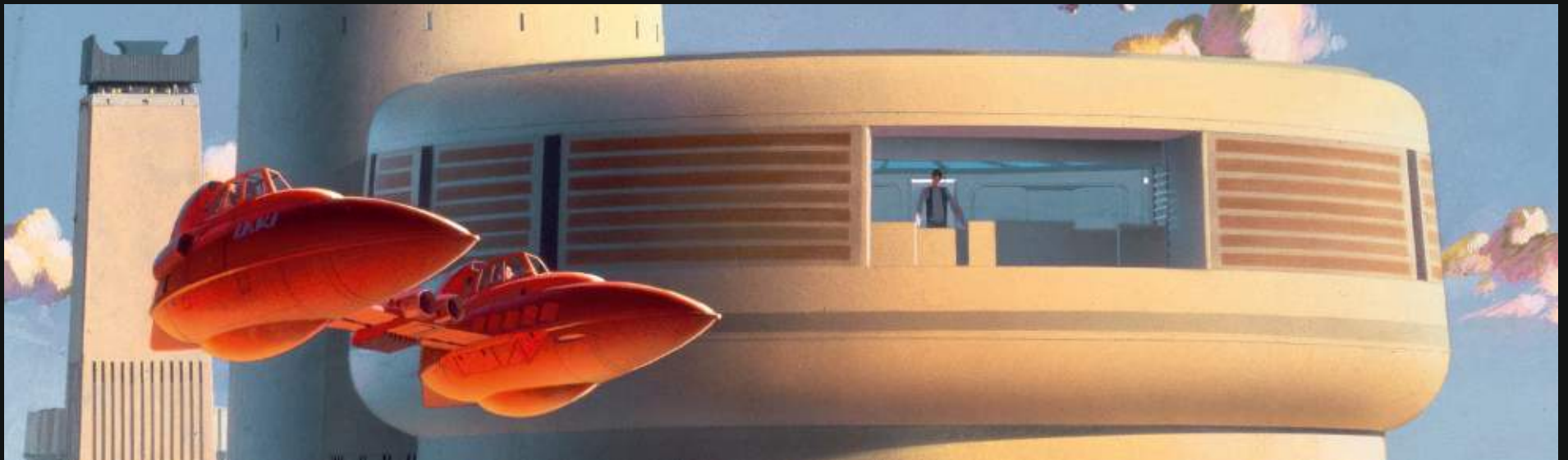

© & ™ Lucasfilm Ltd.

RENCONTRE AVEC LE GRAPHISTE

Madison O'Neil

Quelle est la première étape dans la conception des figurines ?

Les tout premiers pas seraient de décider quels personnages inclure dans l'ensemble et de déterminer les besoins de conception de ces personnages. Des éléments nouveaux ou existants sont-ils nécessaires dans de nouvelles couleurs ? Combien d'éléments imprimés sont nécessaires ? Les personnages nécessitent-ils des textiles ? Quelles sont les meilleures façons de créer de la nouveauté et de l'enthousiasme dans ces personnages classiques ? Une fois que ces questions sont résolues, nous pouvons commencer les tâches de conception plus spécifiques.

Quel type de documents de référence avez-vous utilisé ?

La Cité des Nuages est un lieu classique emblématique, le matériel de référence était donc facile à réunir. Ma manière préférée de rassembler des références est de chercher dans le film et de prendre des captures d'écran des scènes ou des personnages spécifiques dont j'ai besoin. Je trouve que même après avoir vu le film d'innombrables fois, je continue à découvrir de nouveaux détails. Ma plus grande surprise dans cet ensemble a été quand j'ai réalisé que l'intérieur de la cape de Lando est cousu avec un motif complexe, un détail que nous avons pu intégrer dans sa figurine.

Comment avez-vous abordé le fait de transmettre la personnalité d'un personnage dans sa conception ?

Pour les figurines, je trouve que la majorité de leur personnalité doit venir des expressions faciales. Sur l'avant de la tête d'une figurine, nous concevons généralement un personnage avec une expression légèrement neutre, un sourire doux ou un froncement de sourcils léger, selon de qui il s'agit. C'est sur l'arrière de la tête que nous poussons l'expression plus loin pour capturer un autre aspect de la personnalité ou de l'histoire du personnage. Par exemple, le grand sourire charmant de Lando, ou le choc de Luke quand il se rend compte (attention divulgâcheur) que Dark Vador™ est son père.



Madison O'Neil

Même si les figurines sont petites, elles exigent souvent beaucoup de détails.

Comment avez-vous abordé l'incorporation de « costumes » et de visages détaillés sur de si petites figures ?

Il y a un certain niveau de détail qui est considéré comme « l'ADN LEGO® Star Wars » et tout ce qui va au-delà s'éloigne de notre esthétique de conception établie. Concevoir des figurines implique de hiérarchiser les aspects les plus importants et les plus emblématiques des personnages, tout en éliminant peut-être les détails qui pourraient ne pas bien se traduire à l'échelle d'une figurine.

Quelle a été la figurine que vous avez préféré concevoir ? Quelle a été la figurine la plus difficile à concevoir ?

Mes décorations préférées dans cet ensemble se trouvent être celles qui ont aussi été les plus difficiles à créer. C'était une tâche délicate de reproduire le modèle de la robe de la Cité des Nuages de la Princesse Leia à l'échelle d'une figurine, et il en va de même pour le motif répétitif à l'intérieur de la cape de Lando. Mais je pense que ces détails et de nouveaux costumes sont des ajouts passionnants à l'assortiment LEGO Star Wars et raviront les fans.



© & ™ Lucasfilm Ltd.



© & ™ Lucasfilm Ltd.



© & ™ Lucasfilm Ltd.

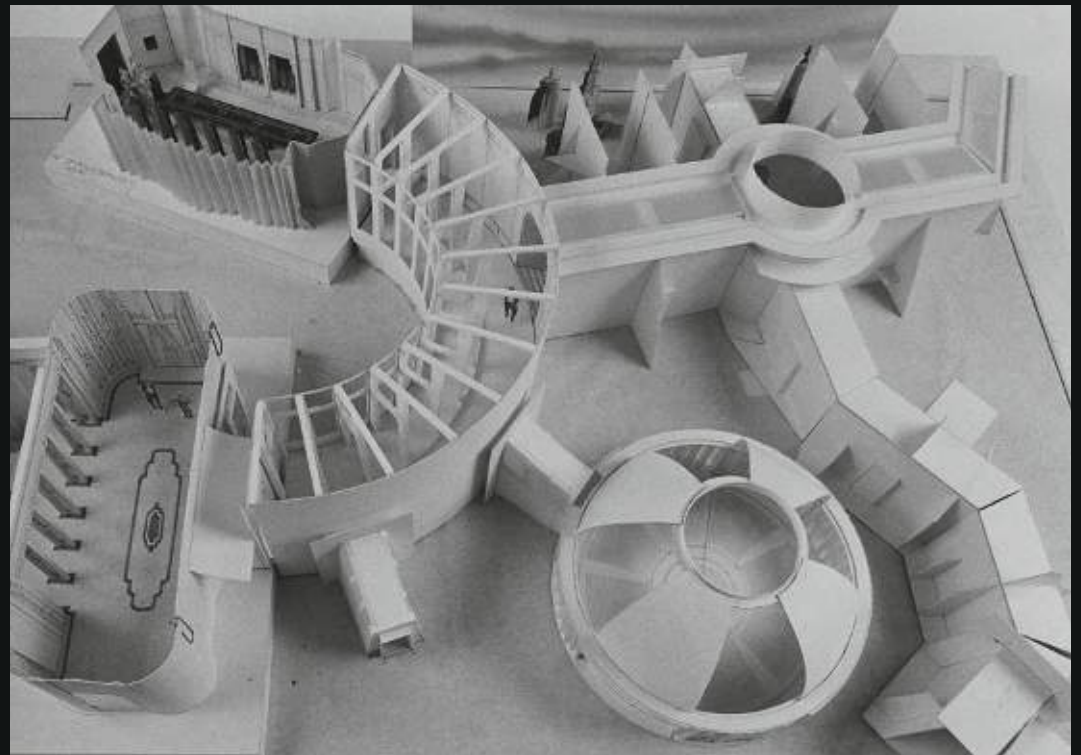

© & ™ Lucasfilm Ltd.



**“ACABO DE HACER UN TRATO QUE MANTENDRÁ
AL IMPERIO FUERA DE AQUÍ PARA SIEMPRE”.**

– Lando Calrissian™



Director de diseño: Jens Kronvold Frederiksen

ACERCA DEL EQUIPO DE DISEÑO DE LEGO® STAR WARS™

La línea LEGO® *Star Wars* inició en 1999 y se ha ido ampliando con nuevos modelos cada año desde entonces. El equipo de diseño de LEGO *Star Wars* se compone de once diseñadores de modelos y cuatro diseñadores gráficos. El grupo combina nuevos diseñadores con ideas frescas y diseñadores con mucha experiencia en el universo LEGO *Star Wars* y un gran número de modelos a sus espaldas.

Es un equipo ideal para la creación de modelos LEGO *Star Wars* innovadores, así como para la revisión y mejora de las antiguas versiones LEGO de las naves más clásicas y populares de la saga. El principal objetivo de la línea LEGO *Star Wars* es hacer llegar a los niños modelos divertidos, modernos e inspiradores basados en este universo.

Para LEGO Direct, es una magnífica oportunidad de crear modelos más grandes y complejos, poniendo especial atención a la precisión y los detalles. Desarrollar estos modelos es divertido y emocionante, ipero también es un gran reto! Siempre nos esforzamos al máximo. ¡Esperamos que disfrutes de la experiencia de construcción!

¡Feliz construcción!

Jens Kronvold Frederiksen
Director de diseño, LEGO® *Star Wars*™



Ralph McQuarrie © & ™ Lucasfilm Ltd.

ACERCA DE LA CIUDAD DE LAS NUBES

La hermosa Ciudad de las Nubes, conocida por su belleza y sus lujos, fue en sus orígenes una colonia dedicada a la extracción de gas Tibanna. Posee una población de varios millones de turistas, trabajadores y profesionales de apoyo, todos ellos suspendidos sobre el gigante gaseoso llamado Bespín. La estación flota a 59.000 kilómetros por encima del núcleo de Bespín, mientras que su disco mide unos 16,2 kilómetros de diámetro. 3.600 repulsores y generadores de rayos de tracción mantienen a la gigantesca ciudad flotando sobre el planeta. La ciudad en sí cuenta con 392 niveles e incluye plataformas y habitaciones para residentes y visitantes. Los 50 niveles más altos de la ciudad integran un centro turístico de lujo del que forman parte casinos tan famosos como el Yarith, el Bespín o el Pair O'Dice. Los niveles inferiores, por su parte, se usan para albergar a los trabajadores que se dedican a extraer y procesar el gas Tibanna.

El proceso de extracción del gas Tibanna se lleva a cabo mediante una serie de rayos de tracción emitidos por la parte inferior de la ciudad que convergen debajo del bulbo reactor de la mina, creando un canal de energía que extrae el gas de la atmósfera inferior

de Bespín a profundidades de más de 23.000 kilómetros. El gas asciende, atravesando una abertura ubicada en el extremo inferior del bulbo desde la que sube por el tallo del reactor y, finalmente, se deriva hacia uno de sus ejes menores, donde se filtra mediante una aleta de procesamiento.

Cada aleta contiene una cámara de congelación en carbonita donde el gas Tibanna se mezcla con dicho material para congelarlo rápidamente y, de este modo, conservarlo. Fue una de estas cámaras la que se usó para congelar en carbonita al contrabandista Han Solo™ luego de su captura por las fuerzas imperiales.

Descansar en la Ciudad de las Nubes es una experiencia memorable, aunque, con frecuencia, muy cara: los centros turísticos de lujo suelen cobrar hasta 5.000 créditos imperiales por noche. Algunas de las actividades más populares entre los turistas son las apuestas, los paseos por la ciudad en auto-nube y las ocasionales visitas a las operaciones mineras locales.

DATOS/ESPECIFICACIONES

Ciudad de las Nubes

Población.....5,5 millones de habitantes
Ubicación.....Bespín
Diámetro.....16,2 kilómetros
Función principal.....Extracción y procesamiento de gas Tibanna

Esclavo I

- Nave de patrulla y ataque clase *Firespray-31* modificada
- Piloteada originalmente por Jango Fett y posteriormente por su hijo, Boba Fett™
- Velocidad máxima de 1.000 kilómetros por hora

Auto-nube de doble cápsula

- Diseñado y fabricado por Bespin Motors para patrullar los cielos que rodean a la Ciudad de las Nubes
- Sistema de propulsión de iones doble Kyromaster
- Velocidad máxima de 1.500 kilómetros por hora



© & ™ Lucasfilm Ltd.



© & ™ Lucasfilm Ltd.

CONOCE AL DISEÑADOR DEL MODELO

Hans Burkhard Schlömer

Llegado el momento de convertir a la Ciudad de las Nubes en un set LEGO®, ¿cuál fue el primer paso?

¡Se podría decir que empecé temprano! Años antes de que se decidiera siquiera desarrollar una nueva Ciudad de las Nubes, construí una pequeña *Esclavo I*, la nave de Boba Fett™, pensando en un futuro set basado en Bespin. Como fan de LEGO *Star Wars* y coleccionista que soy, la Ciudad de las Nubes había ocupado siempre el primer lugar en mi lista de deseos personal, así que no tardé en empezar a pensar en diferentes conceptos. Para mí, la *Esclavo I* pertenece a la Ciudad de las Nubes. Ningún set que no la incluyera parecería estar completo.

Más adelante, aún durante el proceso de diseño, me di cuenta de que tenía que hacer espacio dentro para guardar el bloque de carbonita con Han Solo™ congelado; si no, ¿cómo iba Boba Fett a transportar su botín? ¡Resultó ser un gran desafío al tratarse de un modelo tan pequeño!

¿Qué materiales de referencia usaste?

Mi principal fuente de referencias e inspiración fueron varias imágenes del Episodio V: *EL IMPERIO CONTRAATAACA*. Es interesante observar cómo cambia la iluminación en el escenario de la película, algo que afecta a los colores de ciertas zonas. Creo que los héroes llegan a primera hora de la mañana. Después, va pasando el día y, cuando huyen, el sol se está poniendo. Este fue un aspecto que consideré importante al elegir los colores de la plataforma de aterrizaje, por ejemplo; sé que en realidad es gris, pero nunca se ve de ese color en la película. Eso fue lo que me llevó a elegir cafés más cálidos y oscuros para esa zona.



Hans Burkhard Schlömer

¿Qué es lo que más te inspira del escenario de la Ciudad de las Nubes?

Como diseñador, el diseño del escenario de la película me parece sencillamente asombroso. Posee un estilo *art déco* muy sutil. Tiene un montón de pequeños detalles que sólo se descubren poniendo mucha atención. Quería que esos detalles estuvieran en mi set. ¡Todos!

La atmósfera y los colores también cambian al pasar de un área a la siguiente. ¡Es como un código cromático! Mientras que las salas y los pasillos son principalmente blancos, diáfanos y amplios al inicio, todo eso da paso rápidamente a un opresivo rojo oscuro al entrar en el área de prisiones. Mi detalle favorito son los “ojos amenazantes” que hay en las paredes exteriores de las celdas: luminarias que te miran con furia al pasar junto a ellas.

¿Cuál fue la parte más complicada del proceso de diseño?

El de la Ciudad de las Nubes no fue un proceso de diseño como el resto. La mayoría de los interiores ya estaban ahí desde el principio de un modo u otro, pero el concepto general cambió unas cuantas veces. Uno de los mayores desafíos fue conectar todas las salas de tal manera que al hacerlo dieran forma al modelo. Las cuatro vigas superiores, que conforman el techo o la coraza exterior de la Ciudad de las Nubes, cumplen muy bien con este objetivo sin obstruir las áreas de juego. Nuestra meta era desarrollar un lenguaje de diseño similar al del set de la Estrella de la Muerte, pero usando menos bricks y con todas las salas a la misma altura.

¿Qué te gusta más del set?

¡En realidad, hay dos cosas que me gustan mucho! Una es que las salas están organizadas de forma lógica, lo cual permite representar toda la historia tal como sucede en la película. La otra es que el set incluye dos vehículos a pequeña escala y uno es un auto-nube de doble cápsula: ¡no lo veíamos en formato LEGO® desde hace muchísimo tiempo!

¿En qué se diferencia este set de otros en los que hayas trabajado?

Definitivamente, la Ciudad de las Nubes es el set más grande que he creado hasta hoy. ¡Diseñarlo me llevó aún más tiempo del que invertí en el *Millennium Falcon*™ UCS!

¿Hay algo del diseño original que no haya llegado a la versión final?

Desde afuera, la Ciudad de las Nubes parece un hongo flotante. Sin embargo, me encargaron específicamente un set de juego y estos tienen que ser muy estables y accesibles. Lo que trato de decir es que colocar el set en un soporte a gran altura y encerrarlo en una vitrina no era una opción. Para alcanzar la calidad que queríamos ofrecer, necesitábamos una solución que acercara la plataforma al suelo. Aparte de eso, ¡casi todo lo demás que quería que estuviera en el set está adentro de la caja!

¿Qué parte del set podría sorprender a los constructores?

Los numerosos y variados modelos que componen el set pueden sorprender a más de uno, ¡pero será una sorpresa agradable! Por ejemplo, en la bolsa número dos encuentras un amplio surtido de elementos para construir una detallada nave espacial. Sin embargo, ¡la siguiente bolsa sólo contiene bricks! Son bricks grandes que se usan para crear la base en cruz de la Ciudad de las Nubes. En general, la secuencia de construcción debe tener sentido, ser interesante y proporcionar una extraordinaria experiencia hasta la última bolsa. ¡Disfrute de su estancia en las nubes!

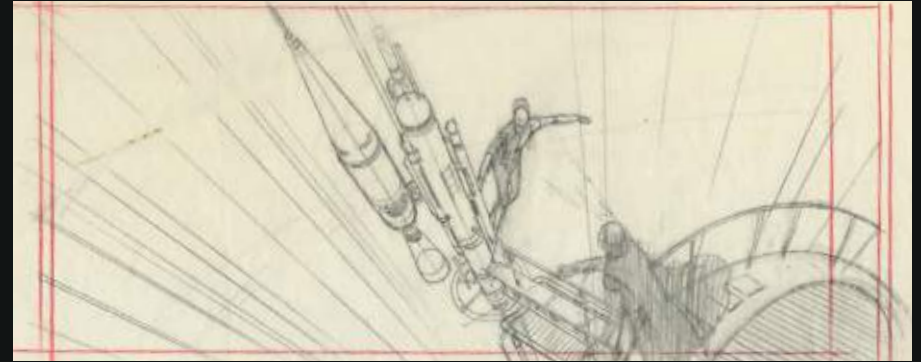

© & ™ Lucasfilm Ltd.



© & ™ Lucasfilm Ltd.

CONOCE AL DISEÑADOR GRÁFICO

Madison O'Neil

¿Cuál es el primer paso a la hora de diseñar las minifiguras de un set?

El primer paso de todos es determinar qué personajes formarán parte del set, así como los requisitos de cada uno de ellos en cuanto a diseño. ¿Hacen falta nuevos elementos o elementos que ya existan en nuevos colores? ¿Cuántos elementos impresos se necesitan? ¿Los personajes requieren textiles? ¿Cuáles son las mejores maneras de darles novedad y emoción a personajes tan clásicos? Una vez contestadas estas preguntas, podemos dar paso a otras tareas de diseño más específicas.

¿Qué tipo de materiales de referencia usaste?

La Ciudad de las Nubes es uno de los lugares más clásicos y emblemáticos, así que fue fácil reunir materiales de referencia. Mi forma favorita de recopilar referencias es buscar en la película y capturar imágenes de las escenas o los personajes que necesito. Siempre descubro detalles nuevos, incluso después de ver la película muchísimas veces. En el caso de este set, me llevé una gran sorpresa cuando descubrí que la capa de Lando está forrada por dentro con una tela muy elaborada, un detalle que pudimos incorporar a su minifigura.

¿Cómo transmites la personalidad de un personaje mediante su diseño?

En el caso de las minifiguras, la personalidad viene determinada casi exclusivamente por las expresiones faciales. En la parte delantera de la cabeza de una minifigura, acostumbramos dibujar el rostro del personaje con una expresión más o menos neutra, una leve sonrisa o el ceño un poco fruncido, dependiendo de quién se trate. Es en la parte trasera de la cabeza donde llevamos la expresión un poco más allá para capturar otro aspecto de la personalidad del personaje o la historia. Por ejemplo, la amplia y encantadora sonrisa de Lando o el desconcierto de Luke al descubrir (alerta de spoiler) que Darth Vader™ es su padre.



Madison O'Neil

Aunque son muy pequeñas, las minifiguras requieren frecuentemente muchos detalles. ¿Cómo logras incorporar “disfraces” y rostros detallados a figuras tan pequeñas?

Existe un cierto nivel de detalle que se considera “ADN LEGO® Star Wars” y todo lo que va más allá suele ser descartado por no ajustarse a la estética establecida.

El diseño de una minifigura pasa por dar prioridad a los aspectos más importantes y emblemáticos del personaje, eliminando, quizá, aquellos detalles que no puedan representarse bien a escala de minifigura.

¿Qué minifigura te gustó más diseñar? ¿Cuál te pareció más difícil?

Las decoraciones que más me gustan de este set son también las que más trabajo me costó crear. Fue complicado reducir a escala de minifigura el diseño del traje que lleva la Princesa Leia en la Ciudad de las Nubes, al igual que el patrón de la cara interna de la capa de Lando. Sin embargo, creo que tanto esos detalles como los nuevos trajes son novedades fantásticas para el surtido LEGO Star Wars y de seguro les encantarán a los fans.



© & ™ Lucasfilm Ltd.



© & ™ Lucasfilm Ltd.



© & ™ Lucasfilm Ltd.

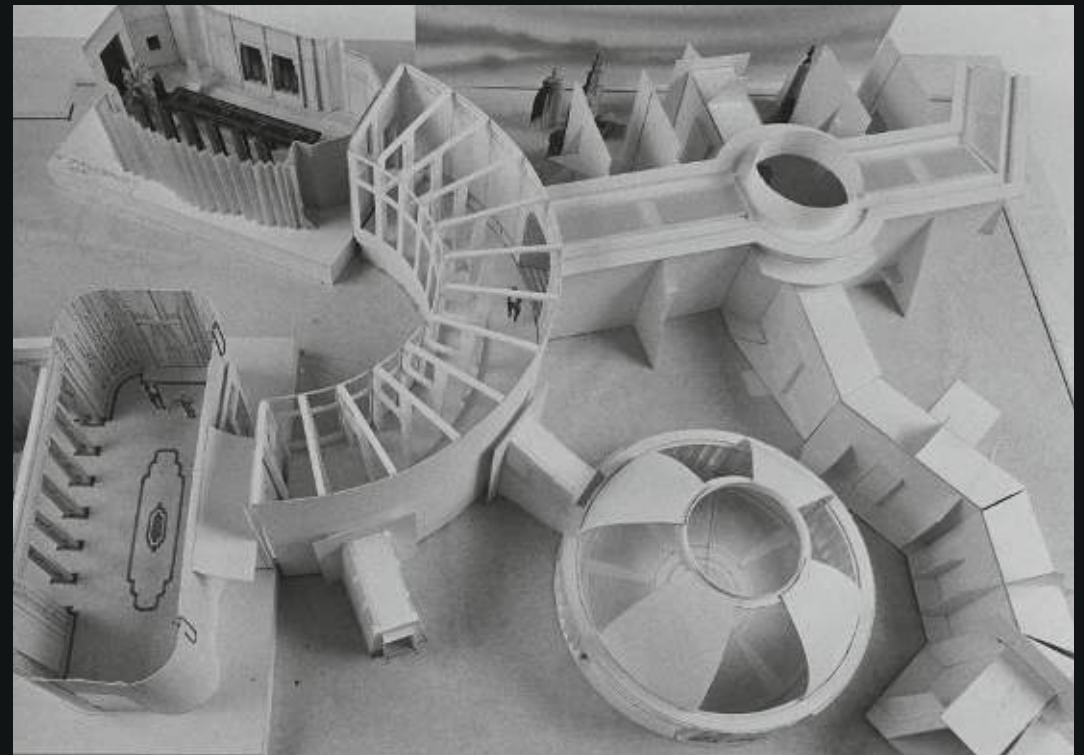

© & ™ Lucasfilm Ltd.

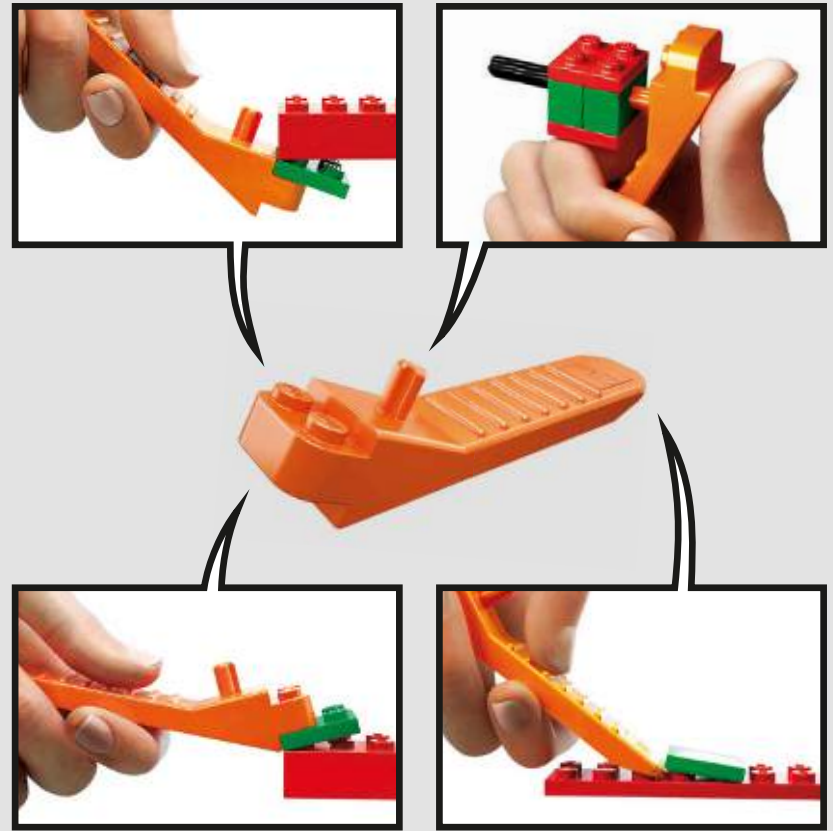

[LEGO.com/brickseparator](https://www.lego.com/brickseparator)

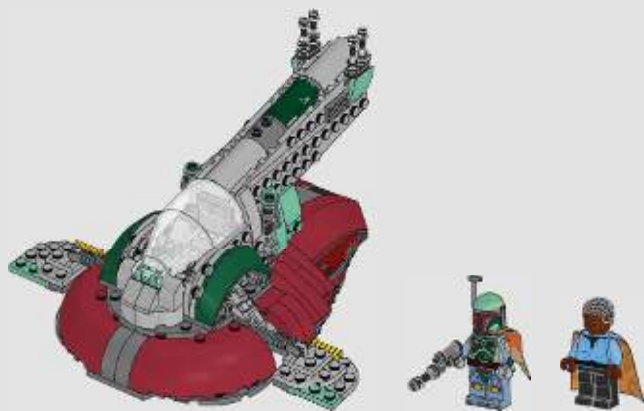
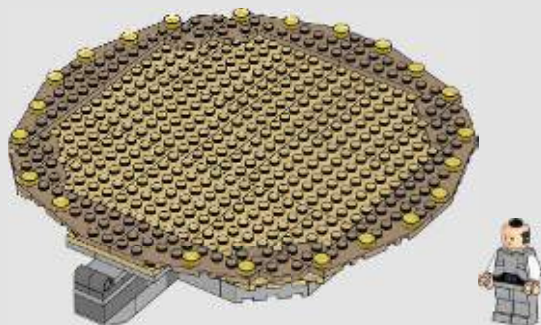

3

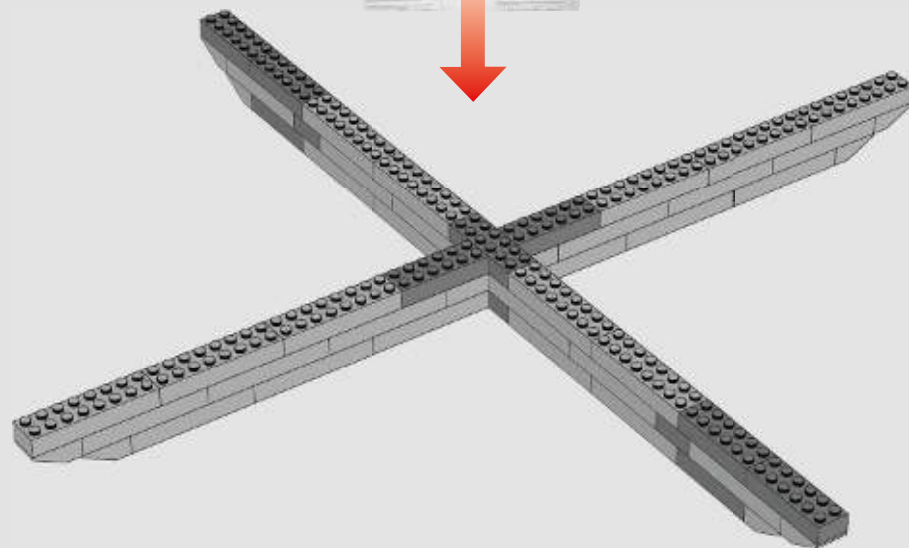

4

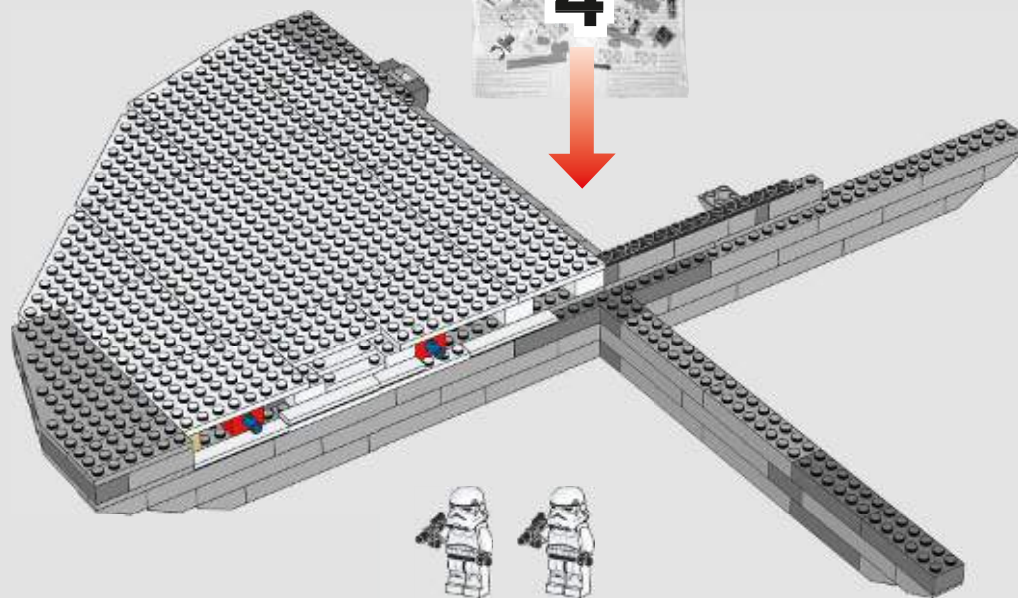

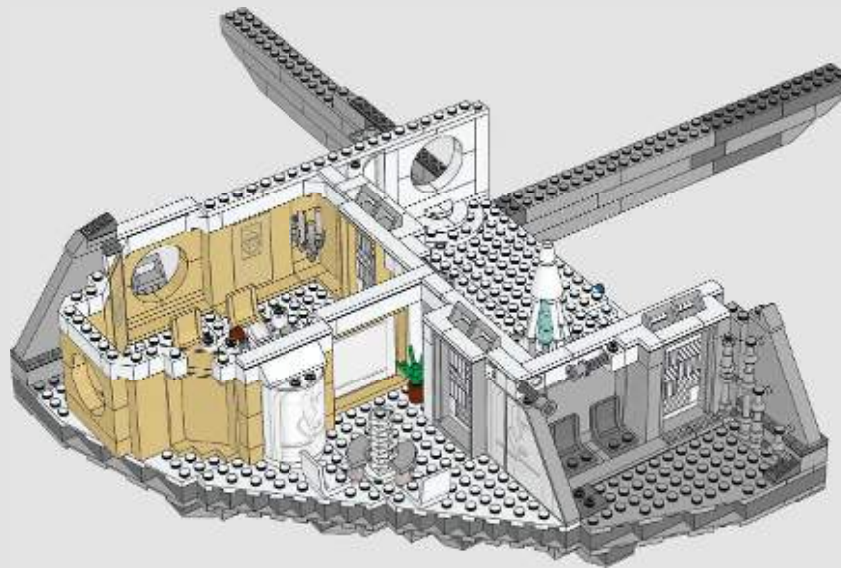



7



8

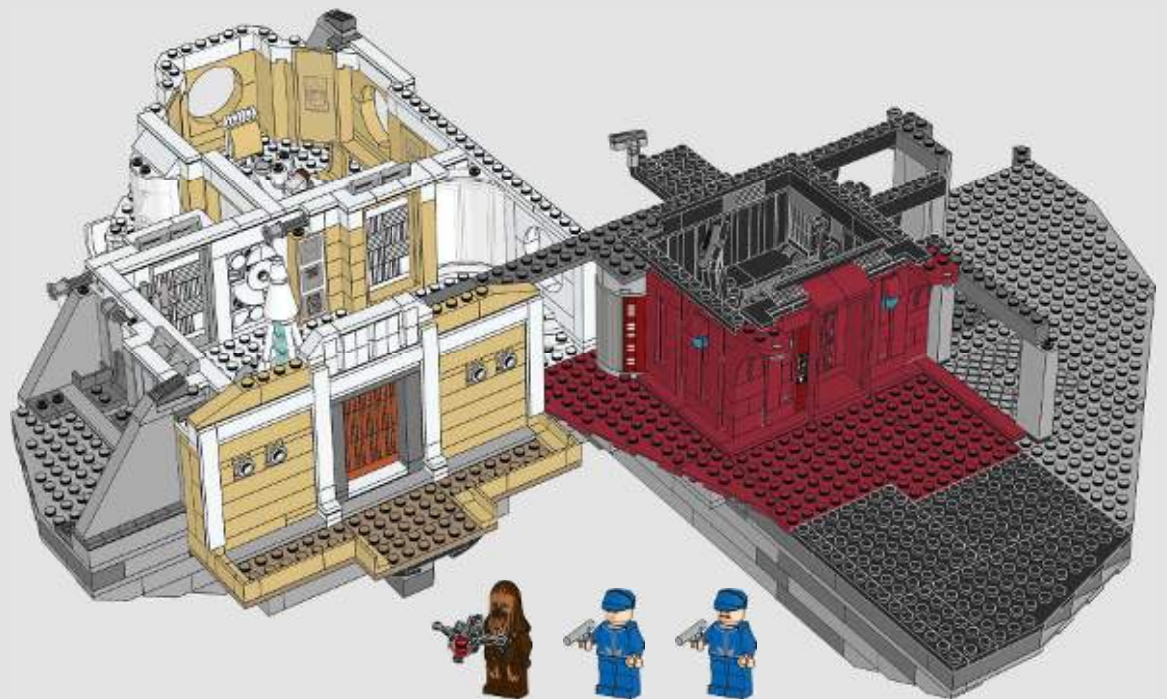



9



10

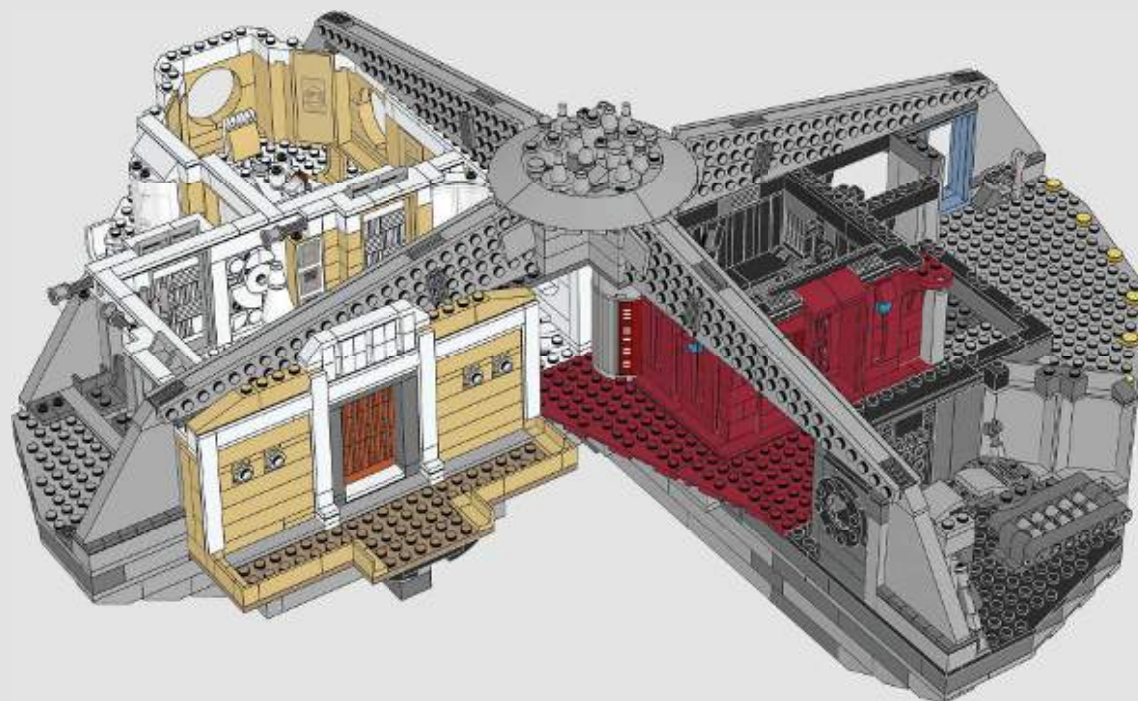



11

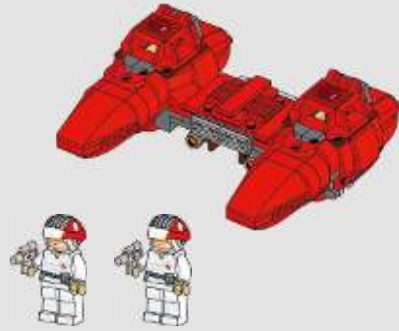

12

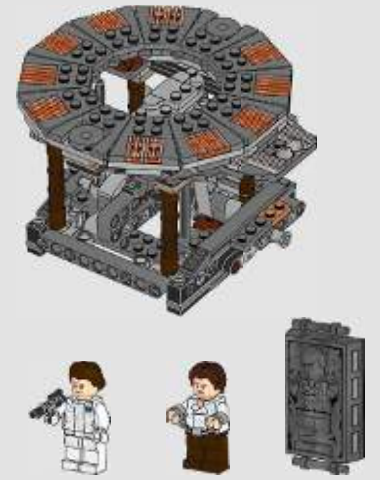

13

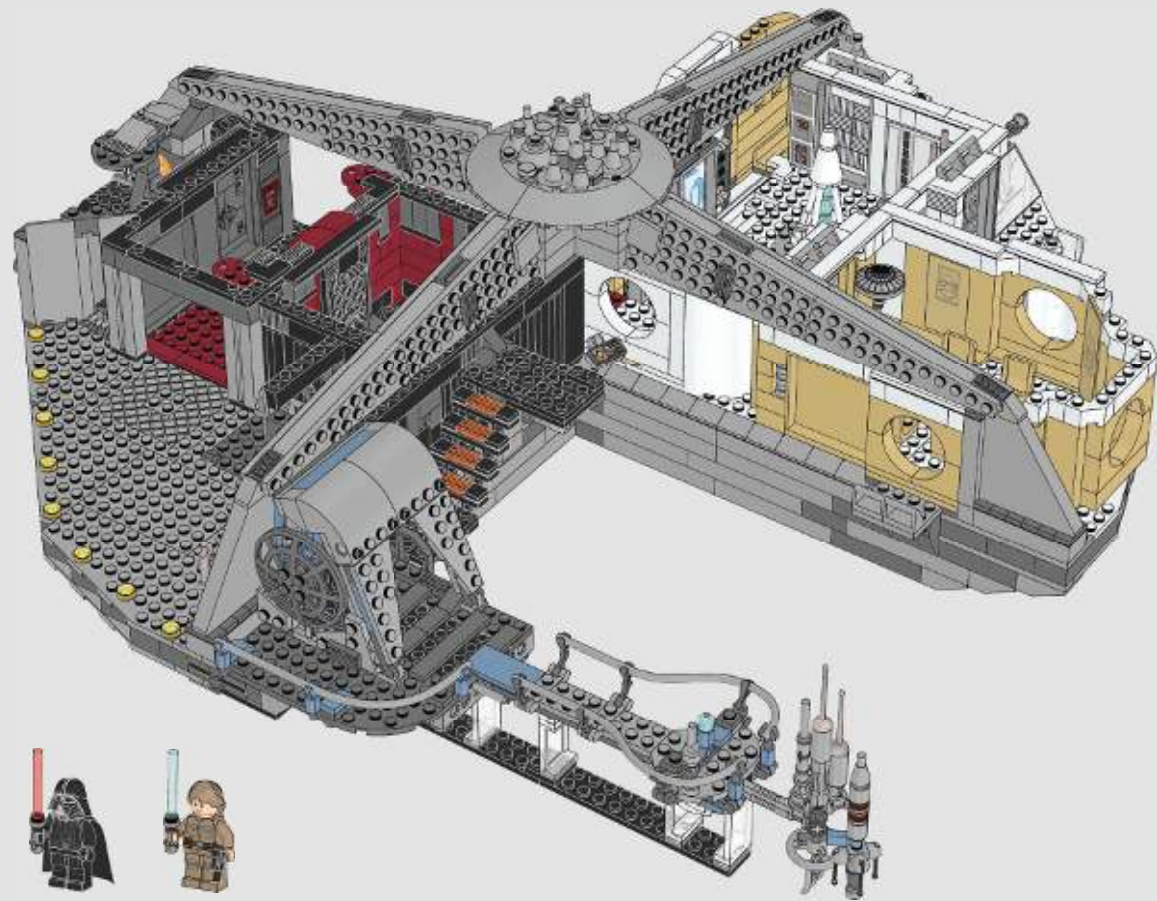

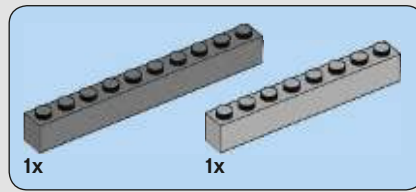
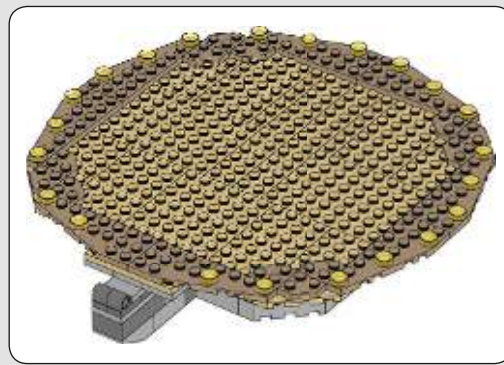
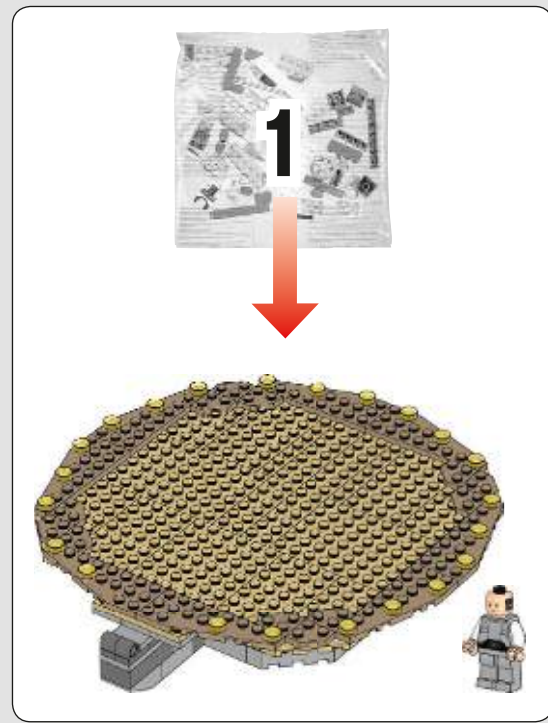

1

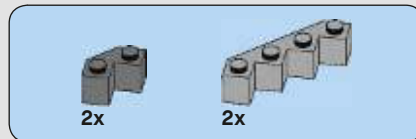
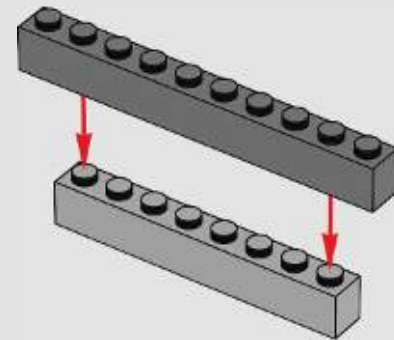

2

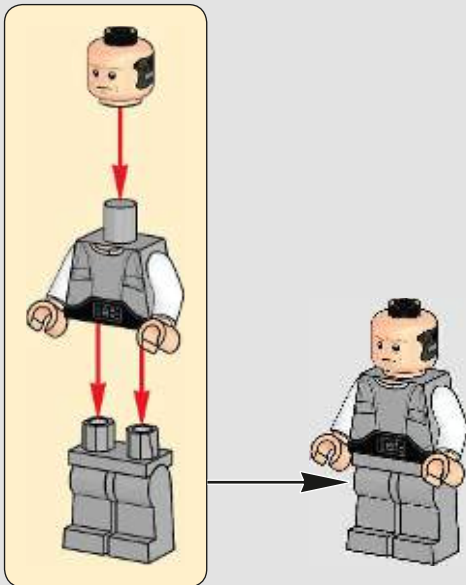
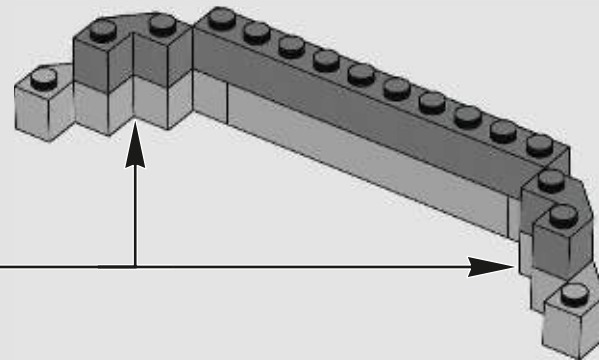
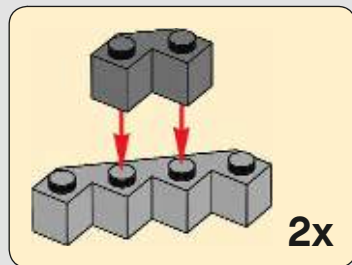

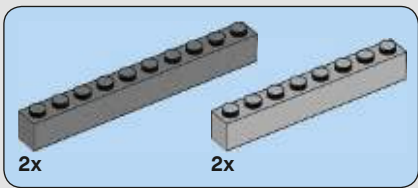

3

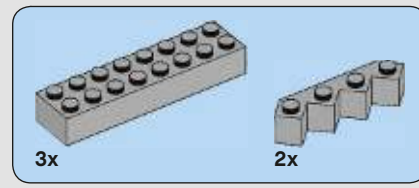
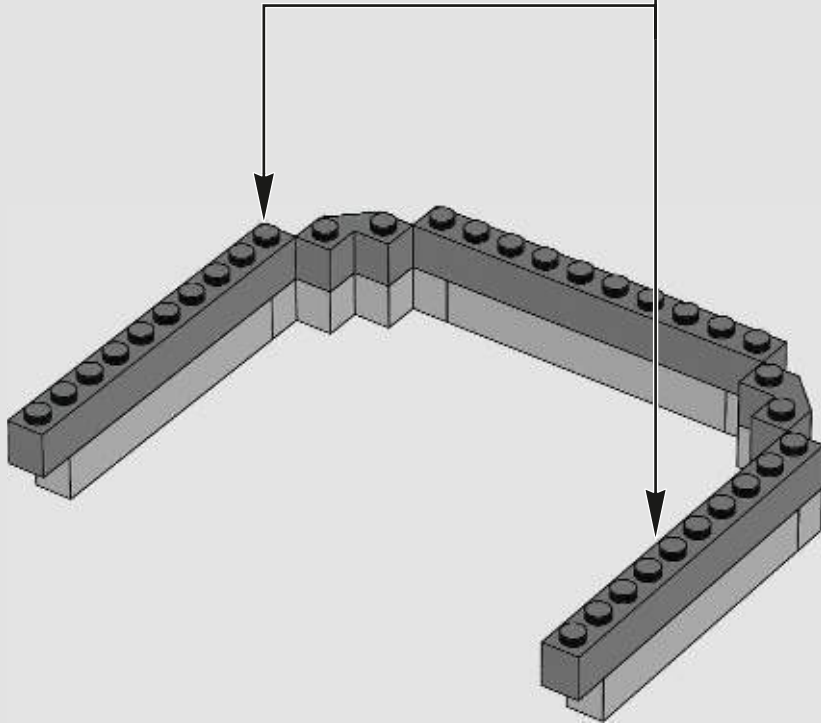
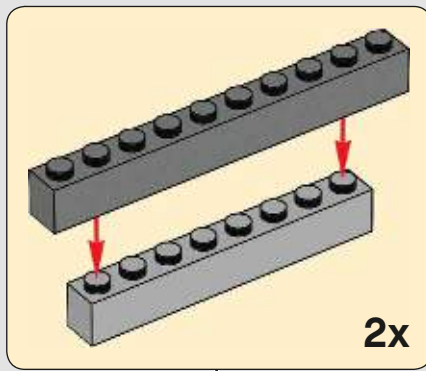

4

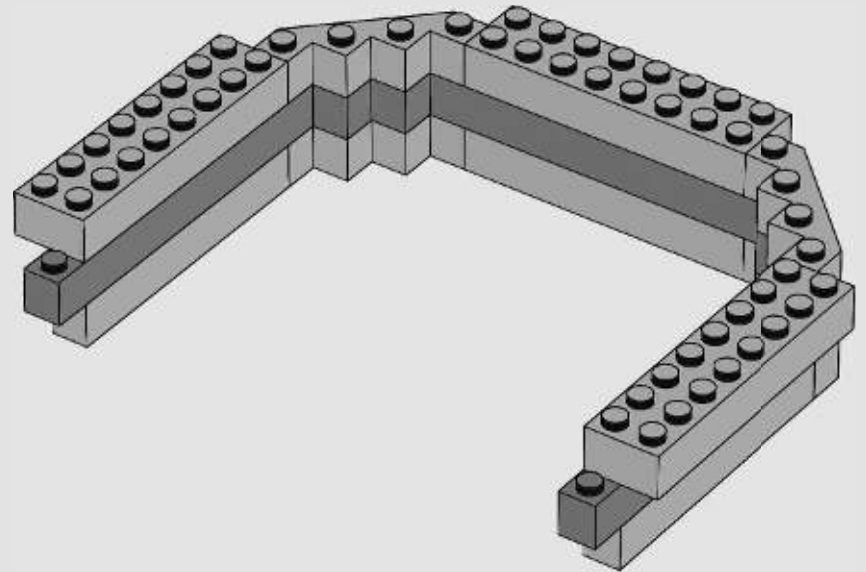

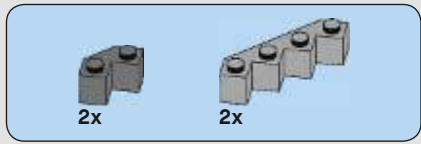

5

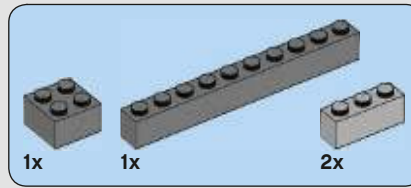
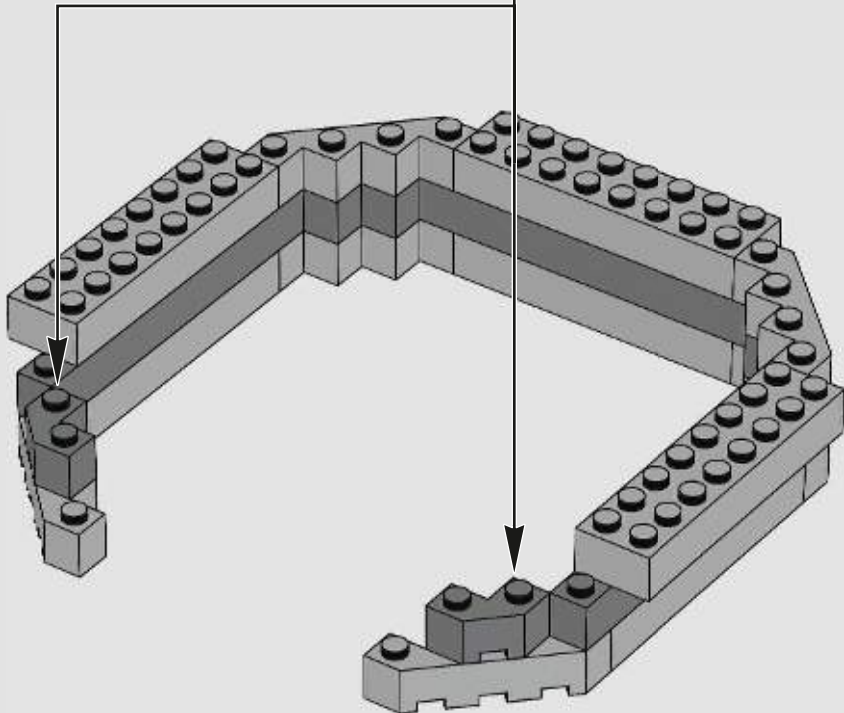
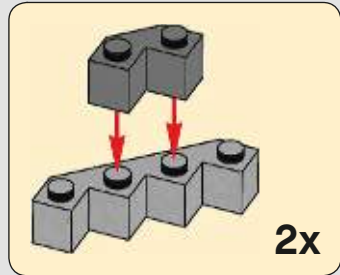

6

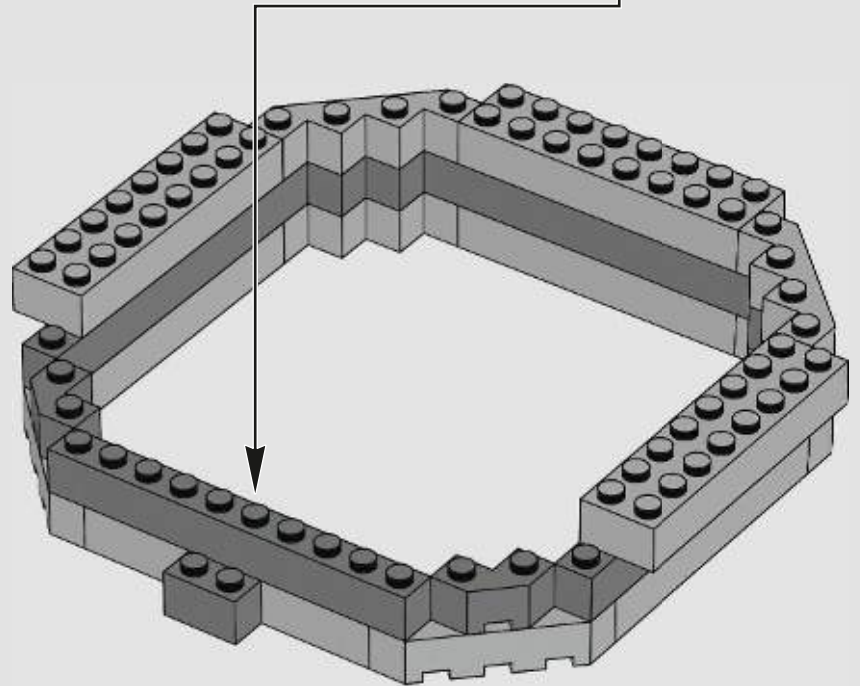
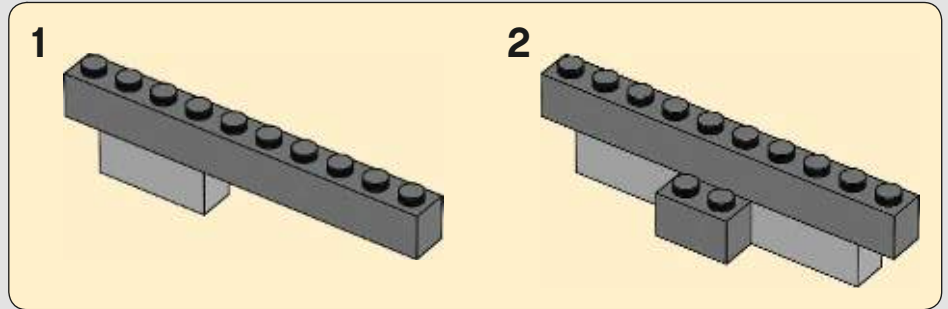

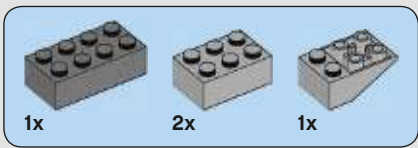

7

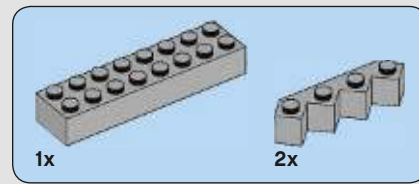
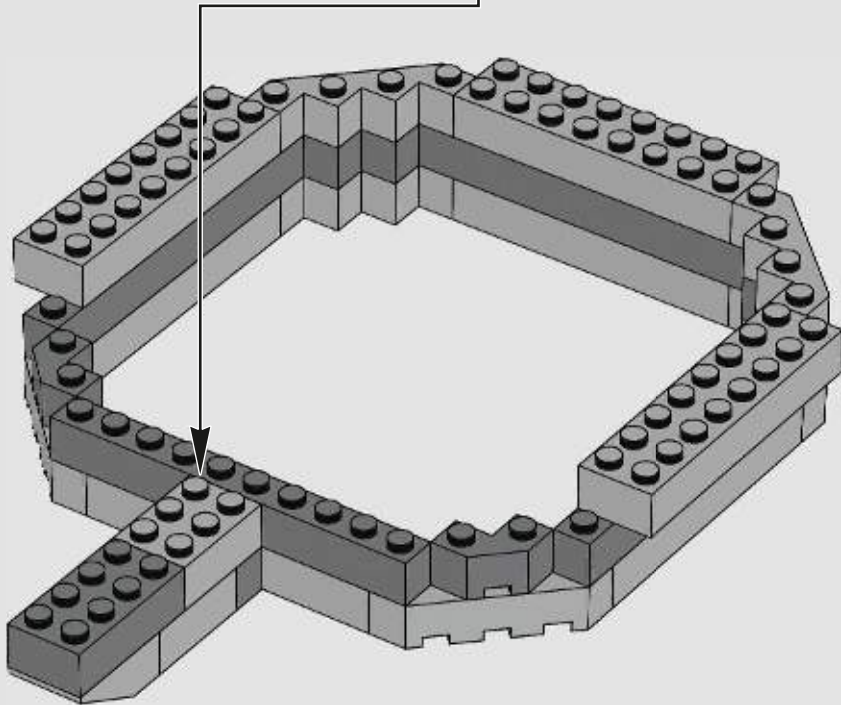
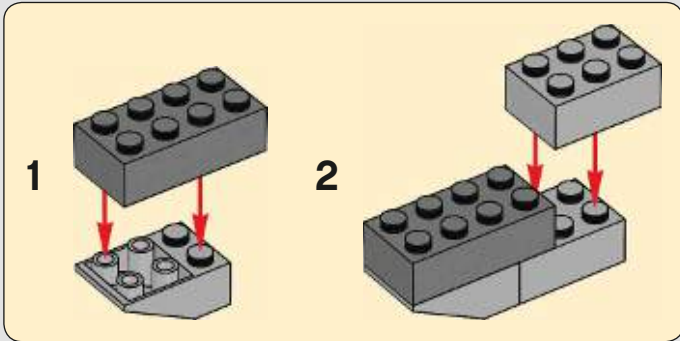

8

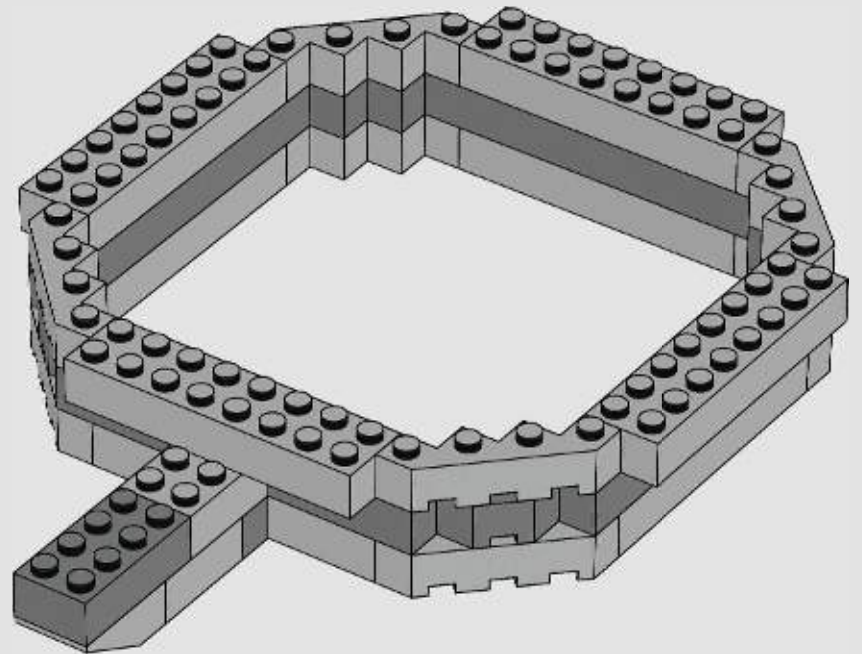

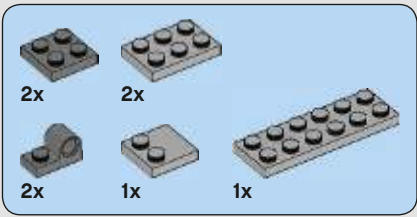

9

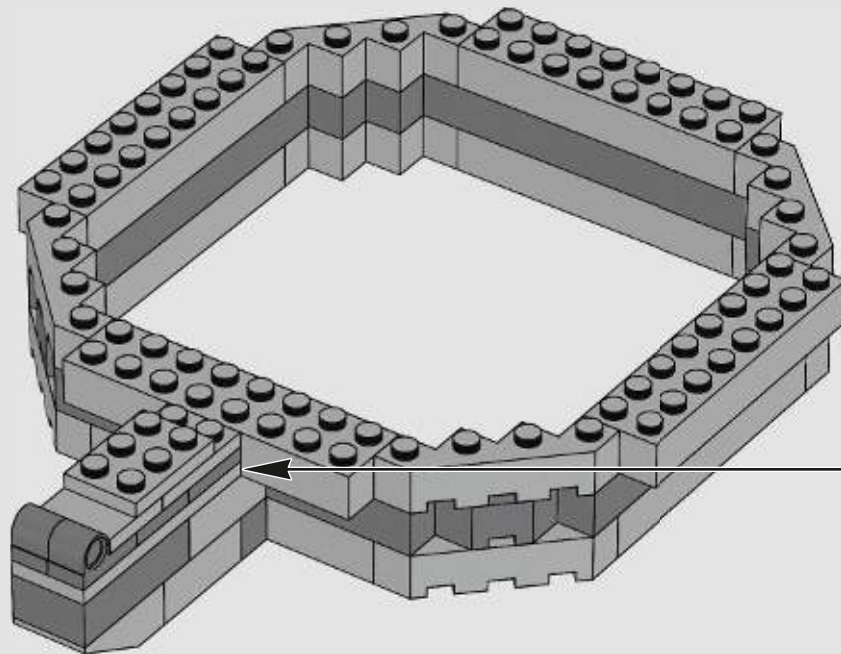
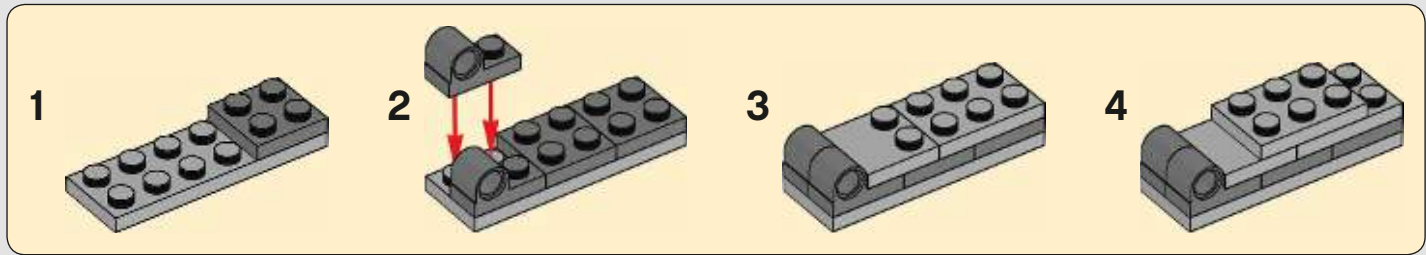

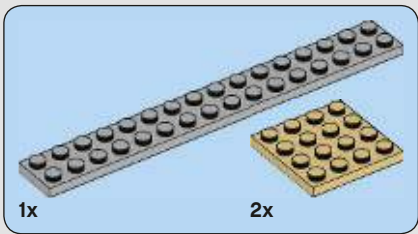
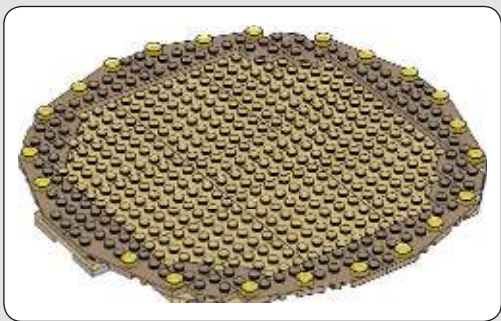

10

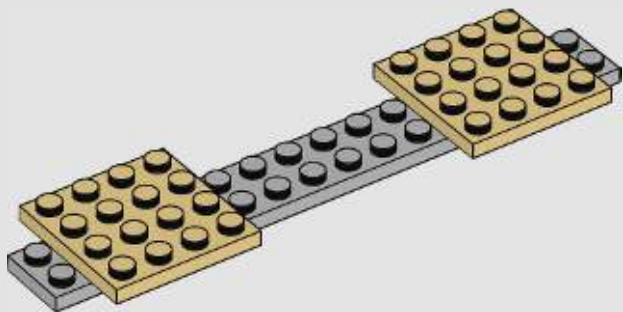

11

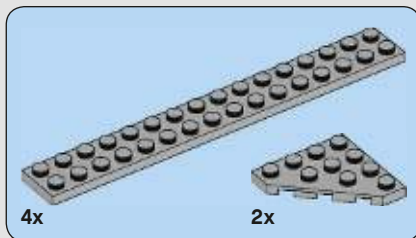
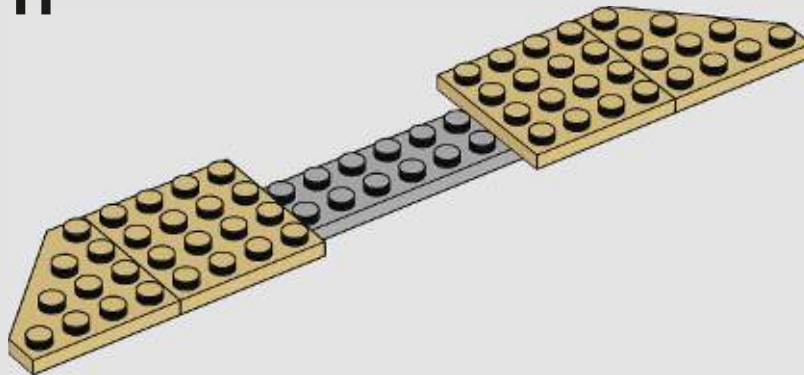

12

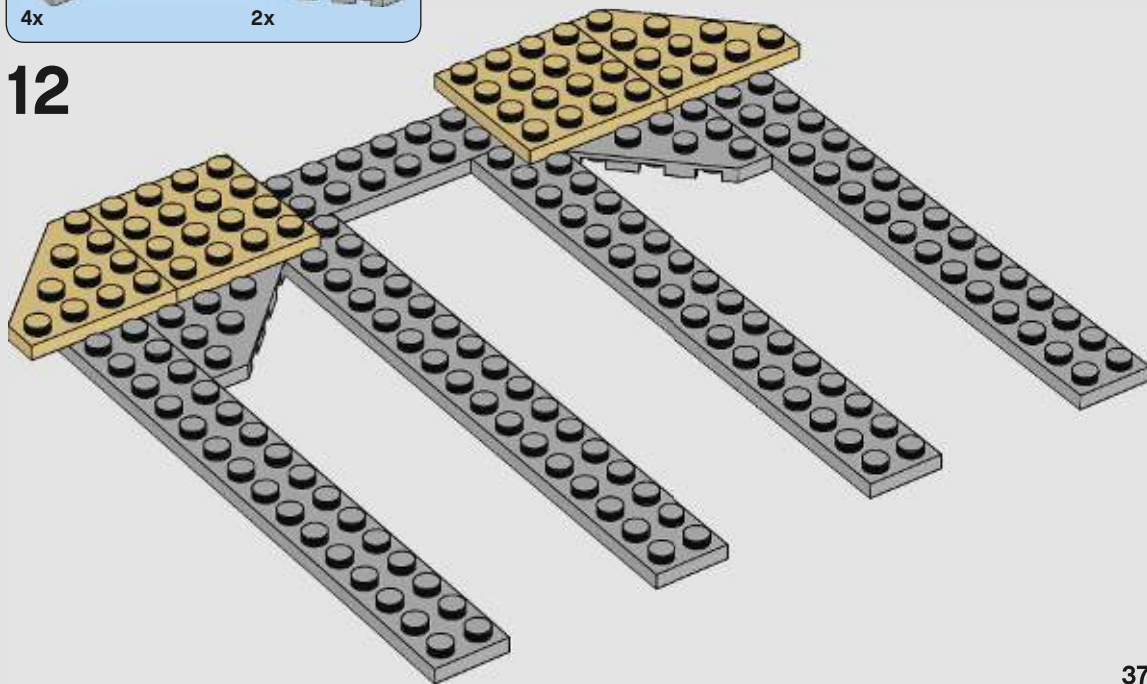

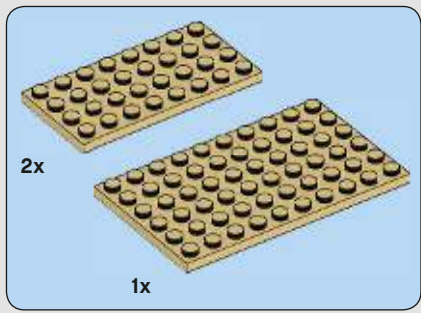

13

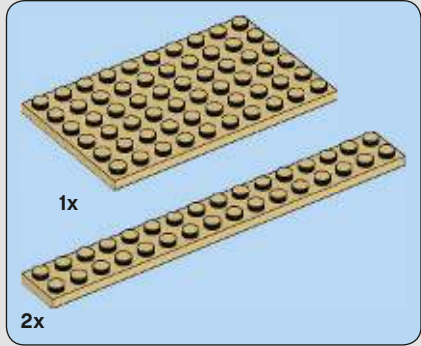
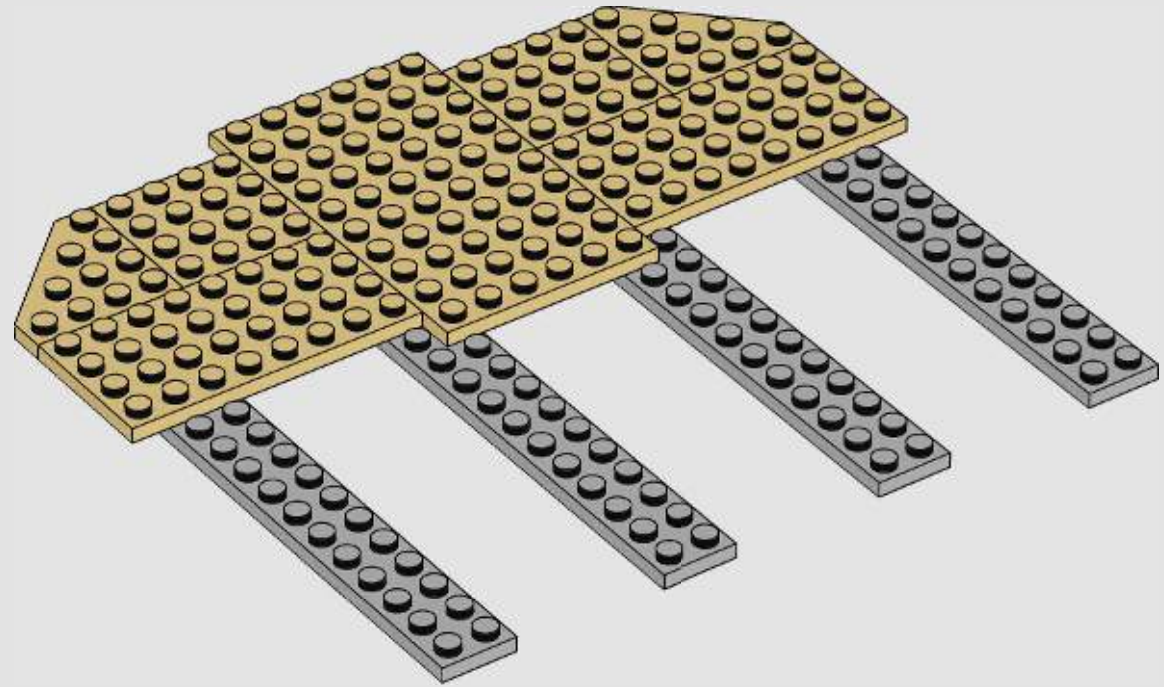

14

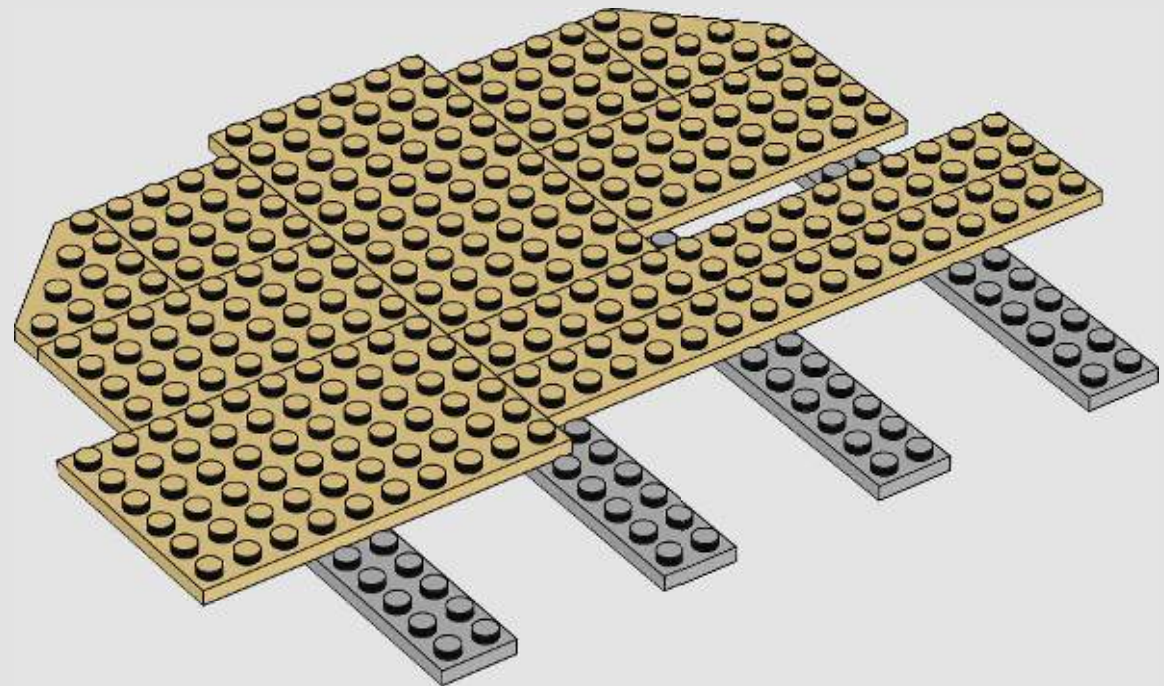

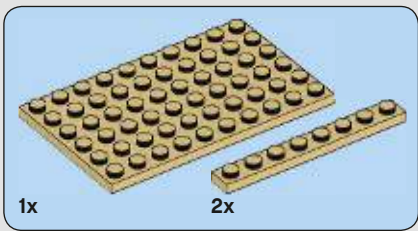

15

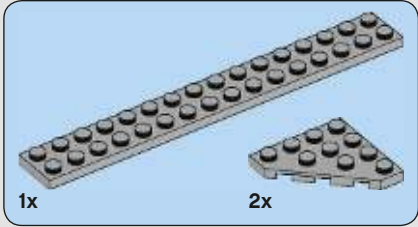
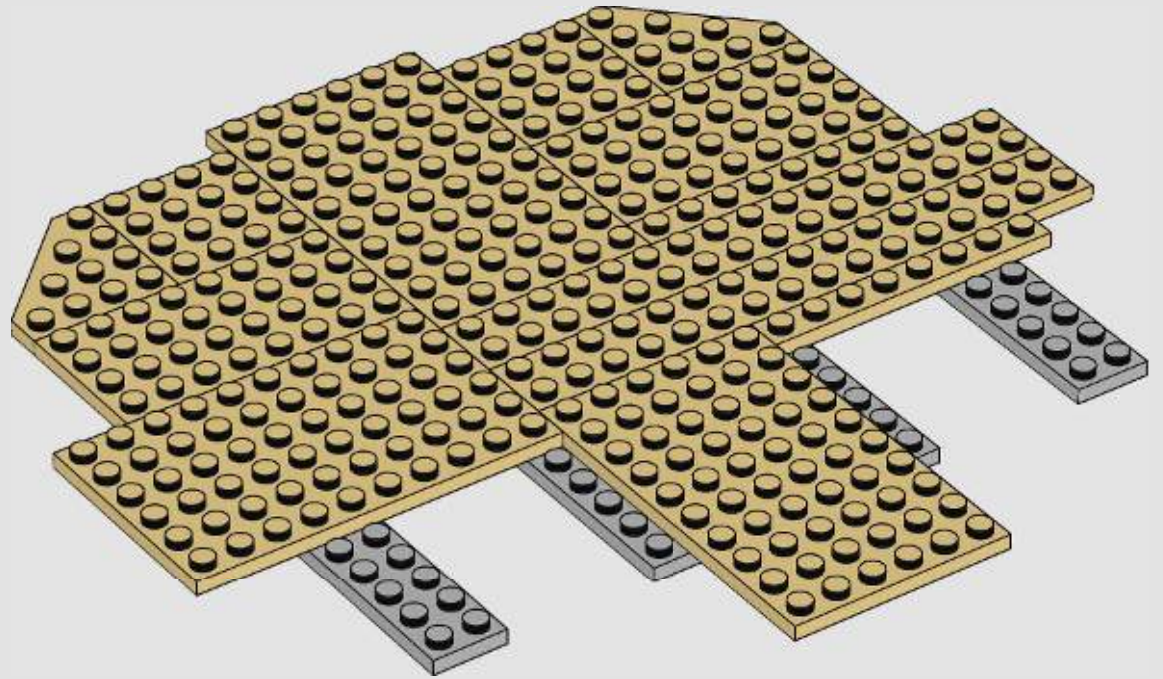

16

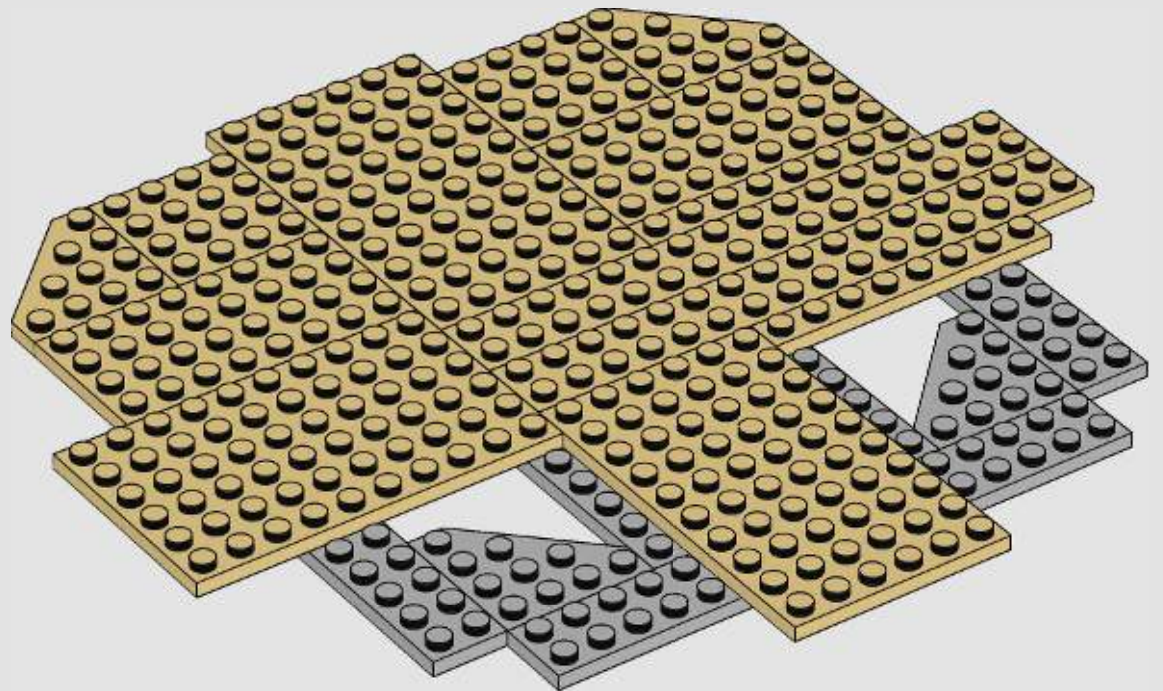

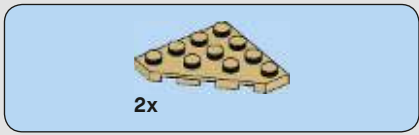

17

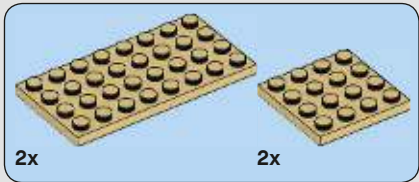
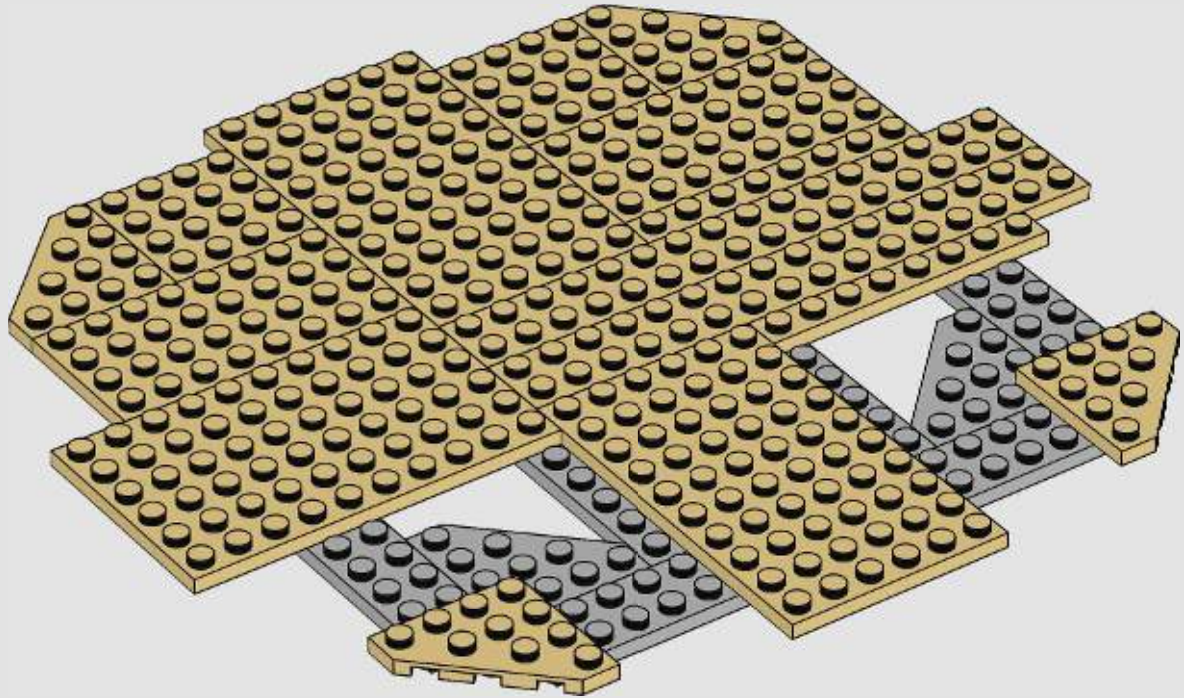

18





19

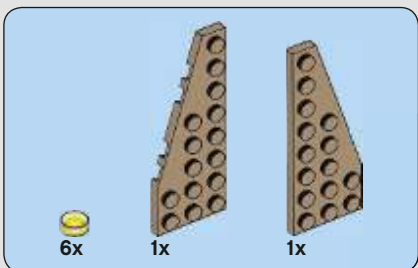
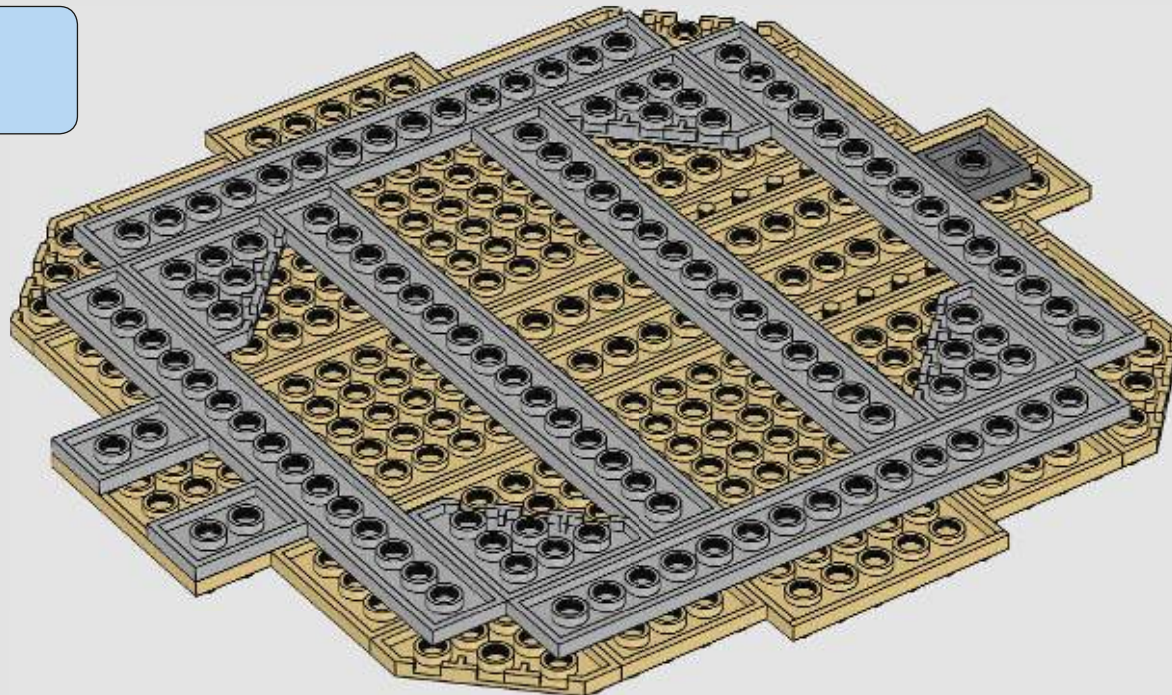
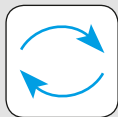

20

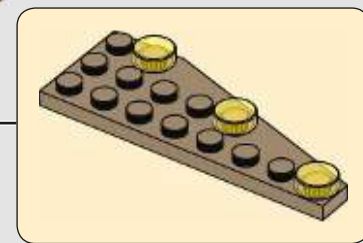
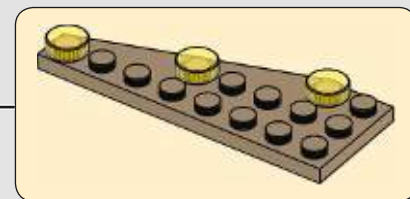
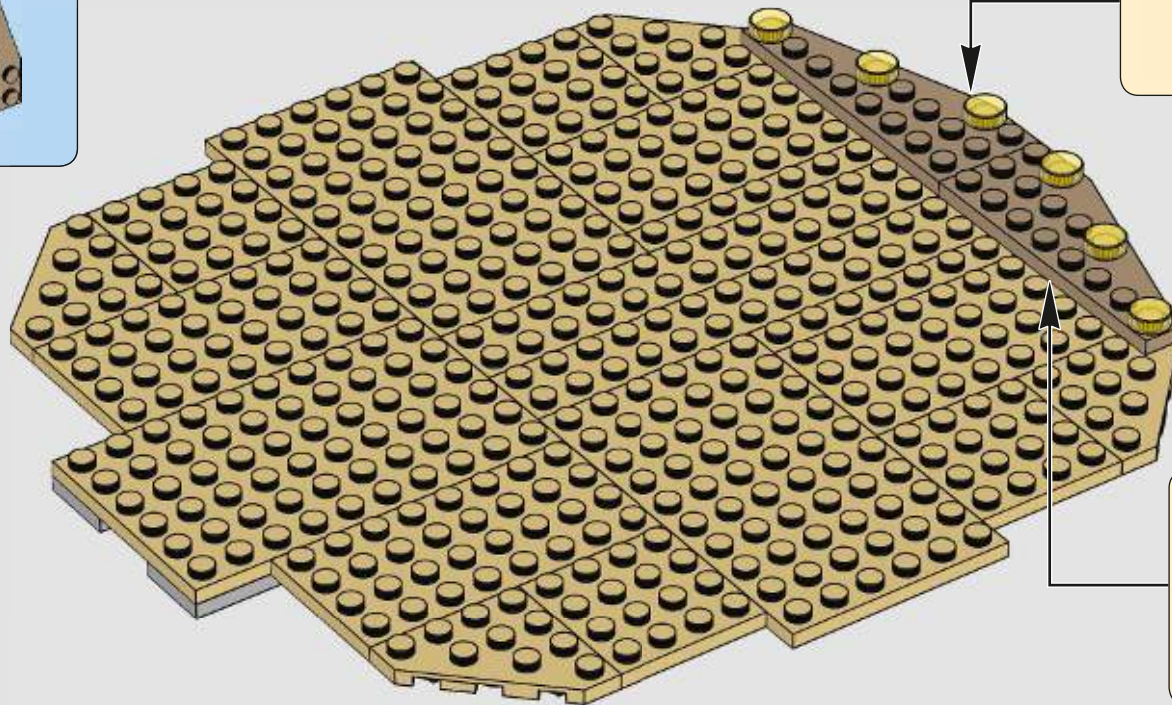
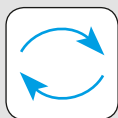



6x

21

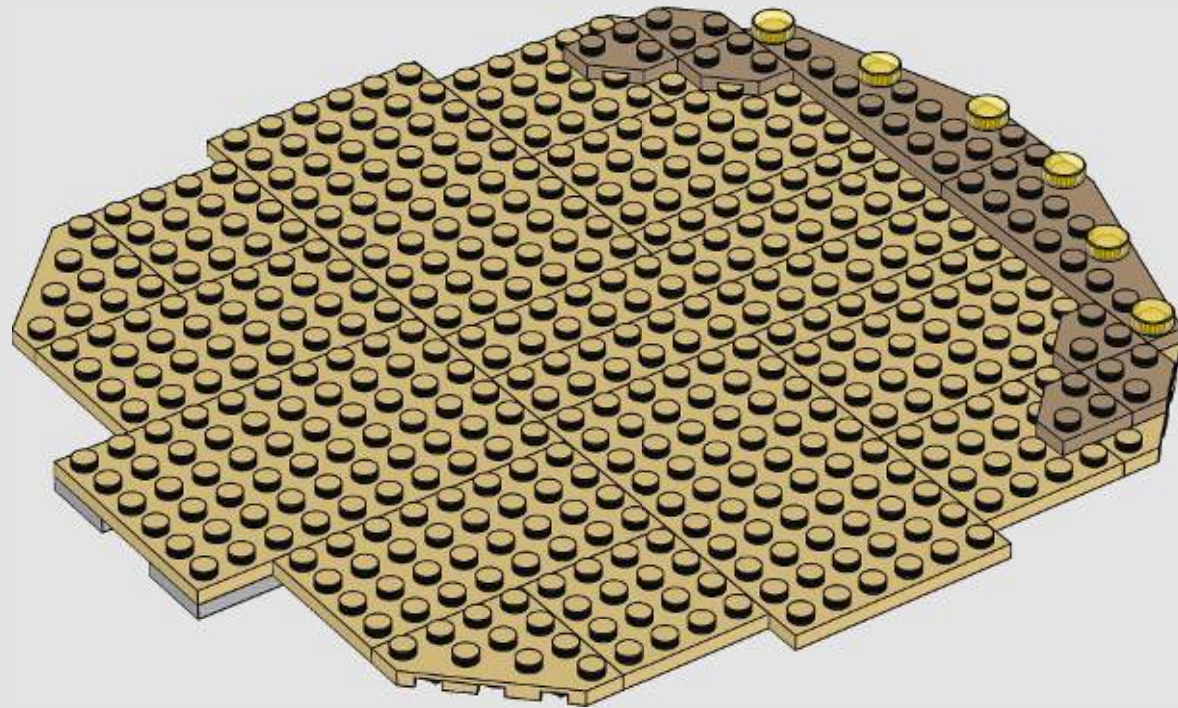

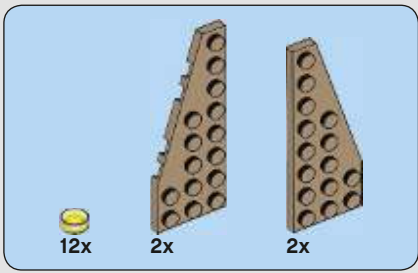

22

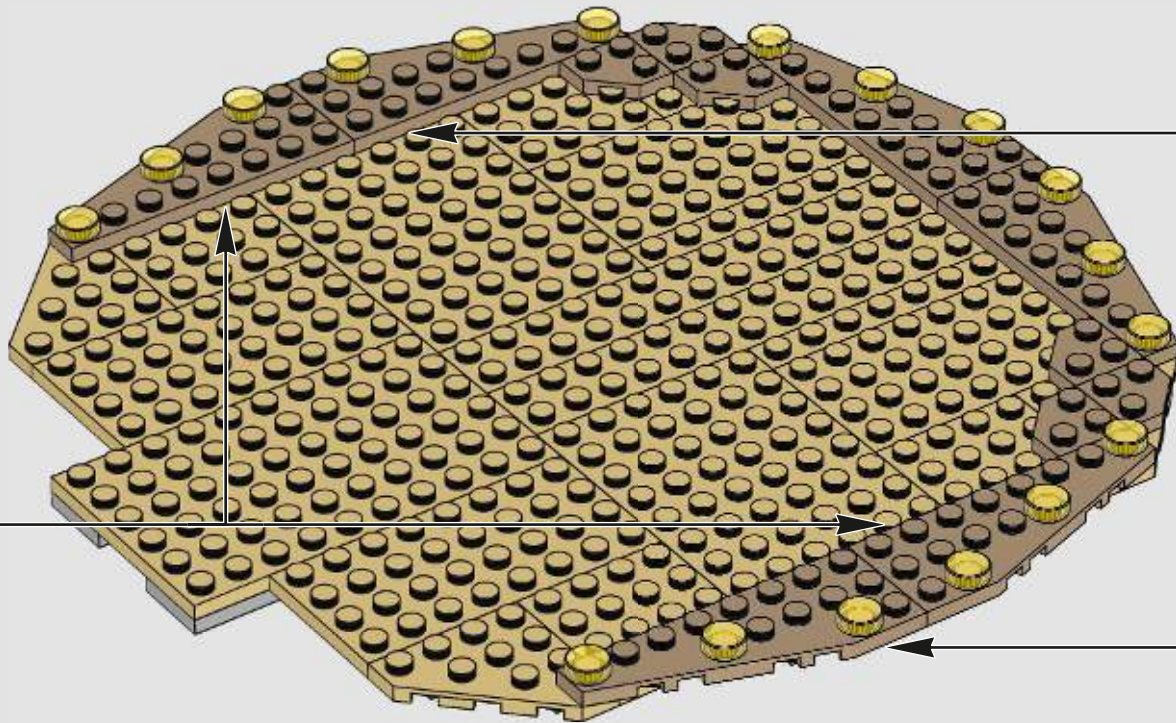
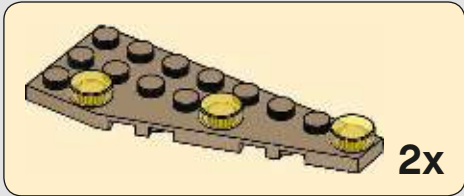
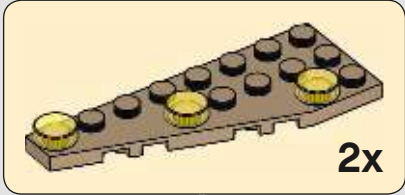



6x

23

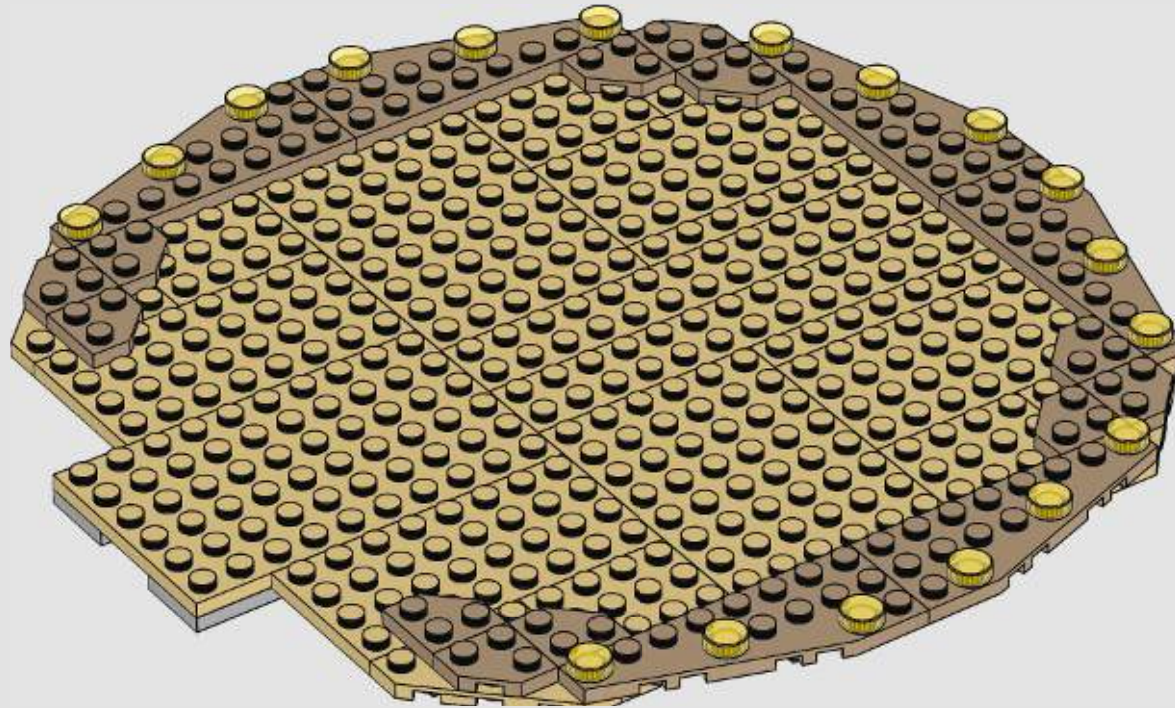

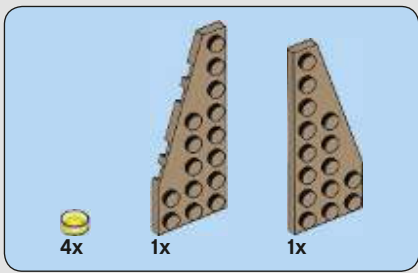

24

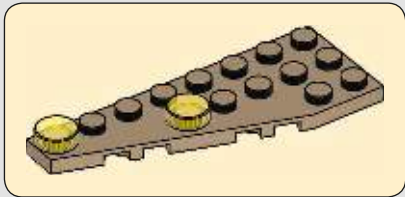

25

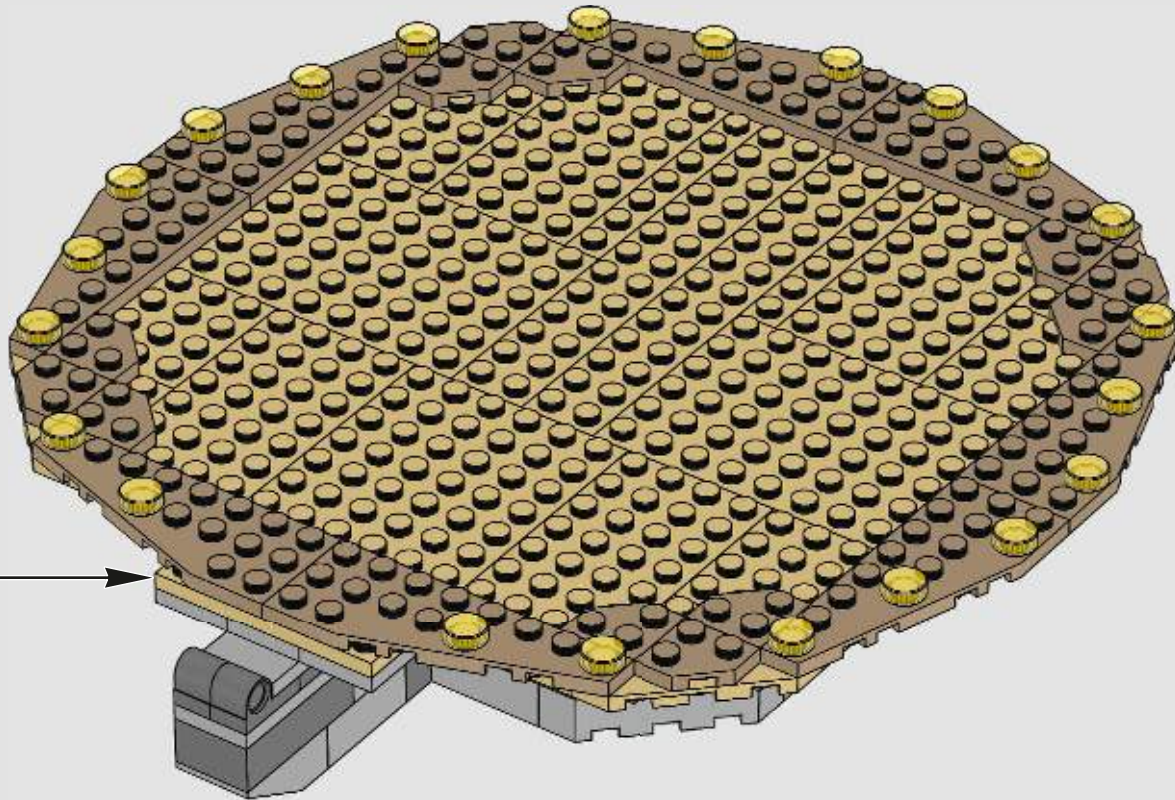

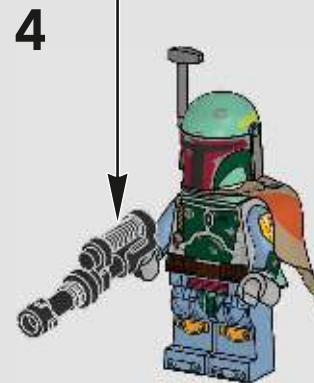
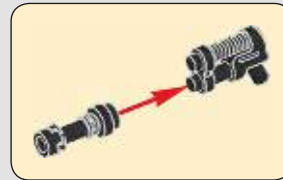
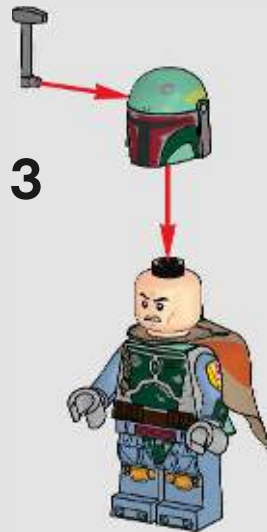
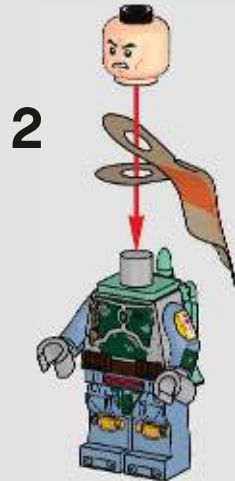
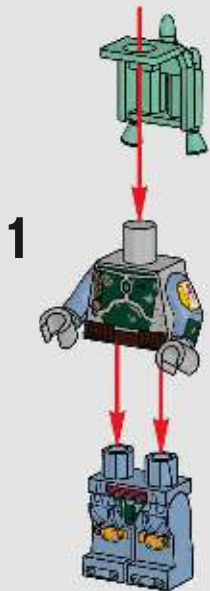
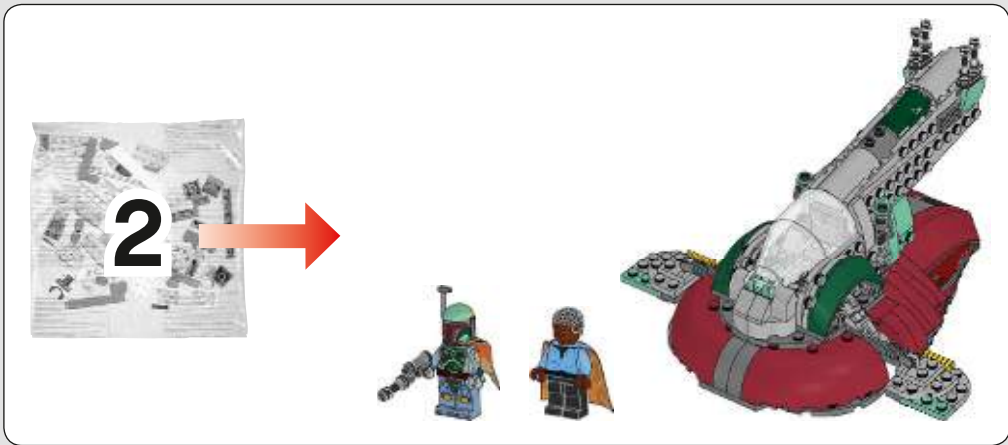

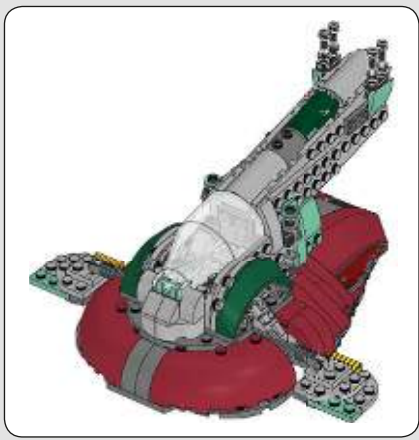

1

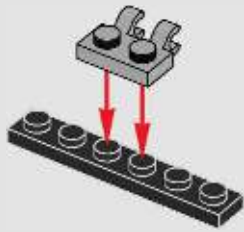

2

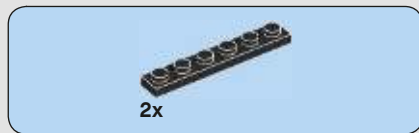
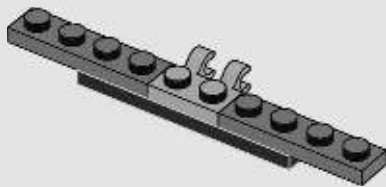

3

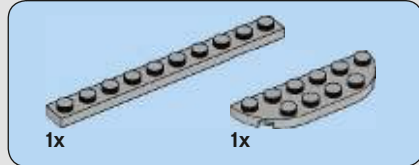
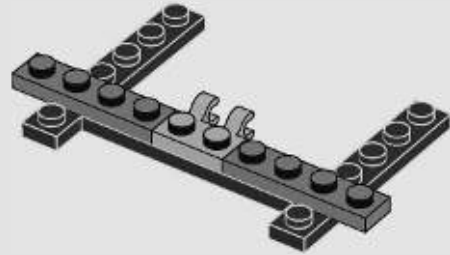

4

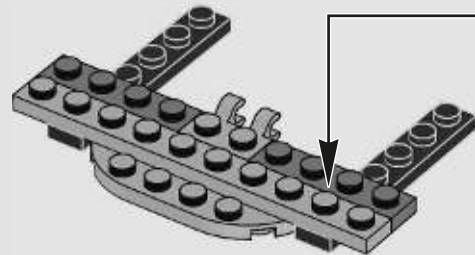
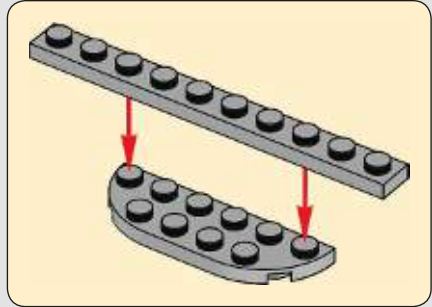

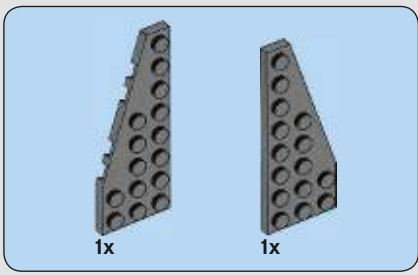

5

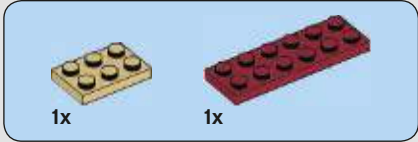
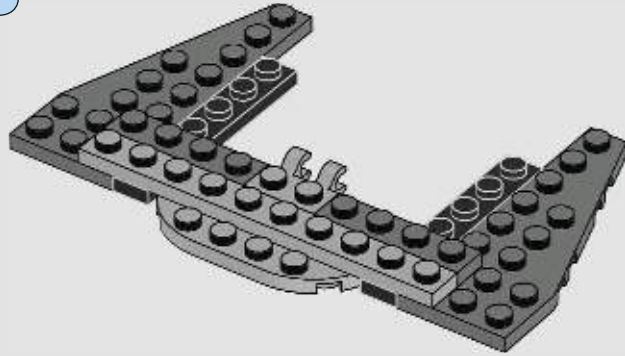

6

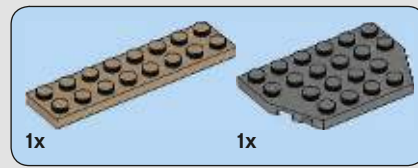
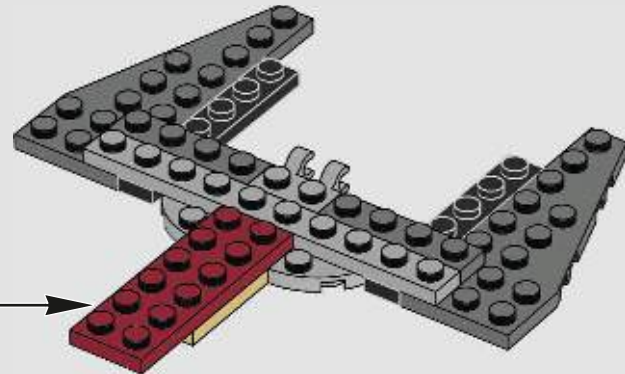
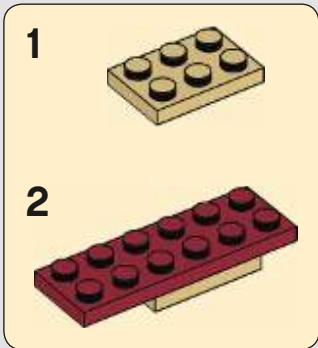

7

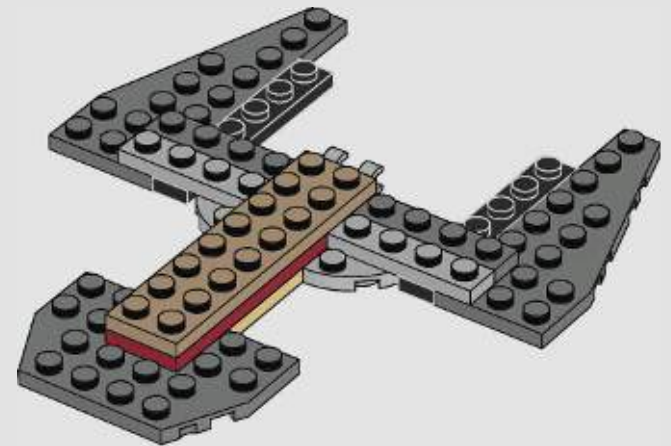



8

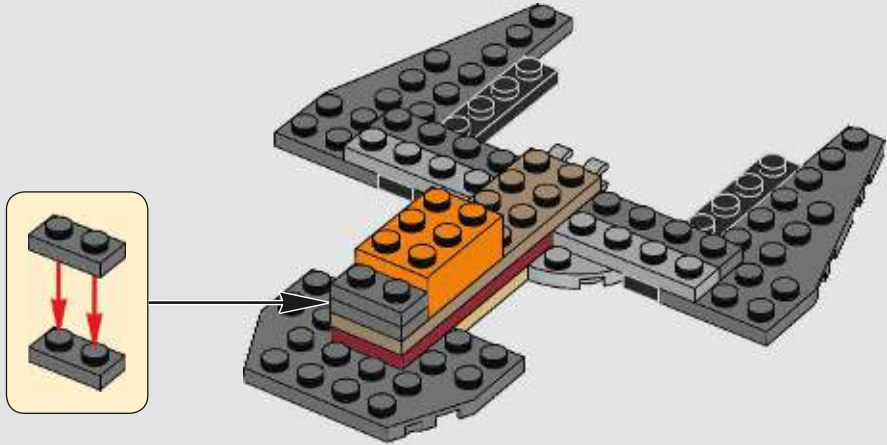

9

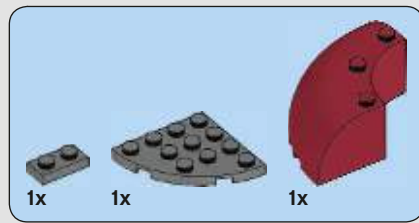
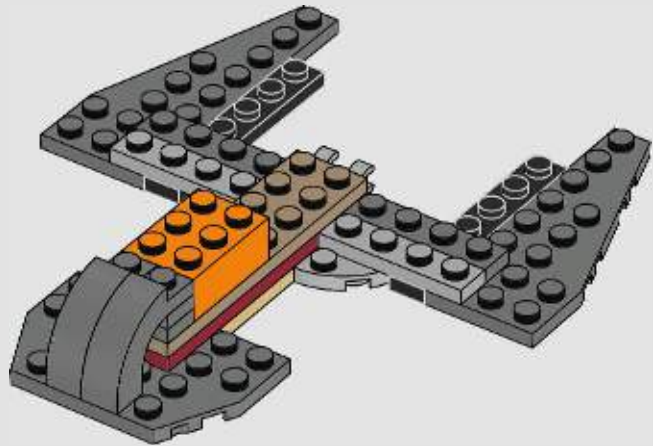

10

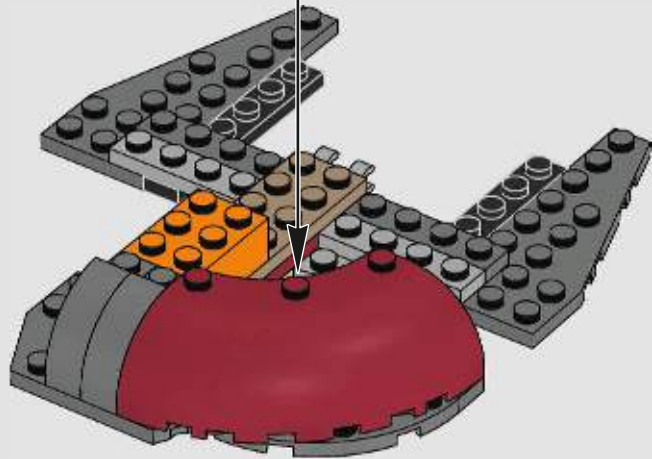
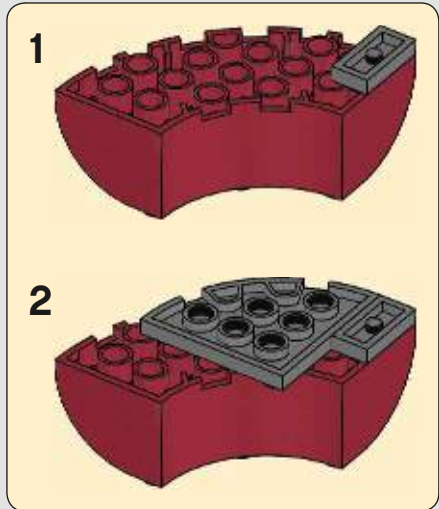

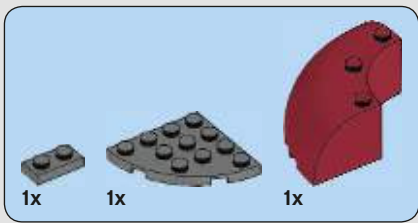

11

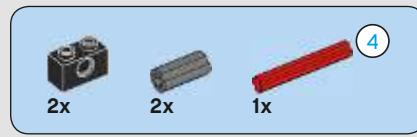
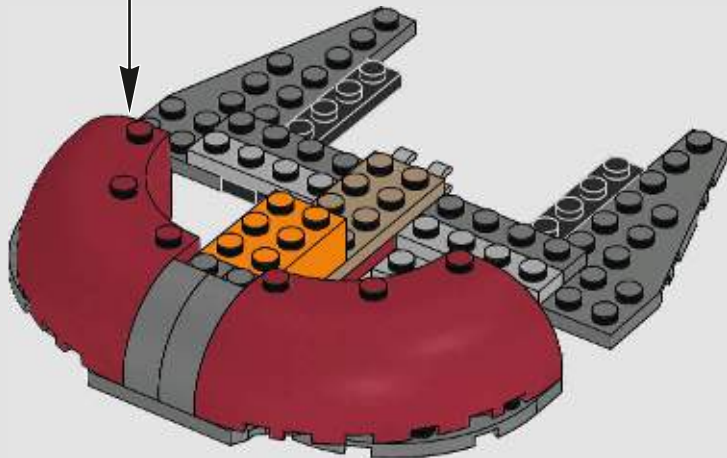
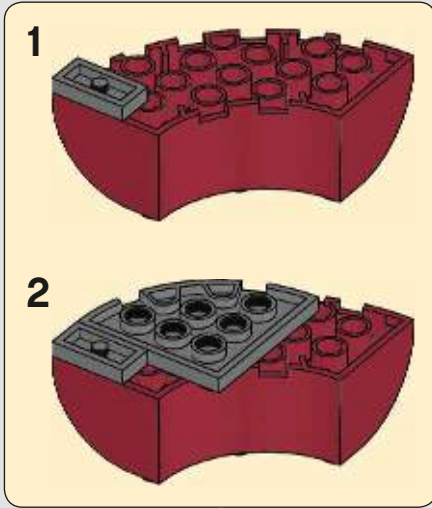

12

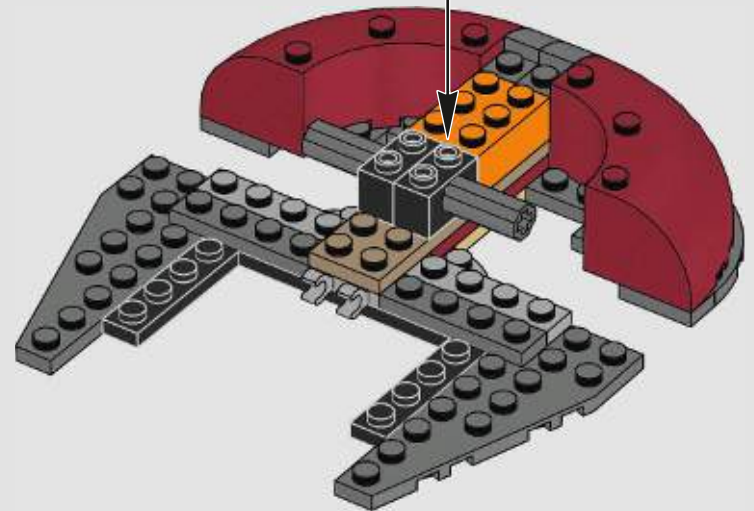
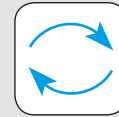
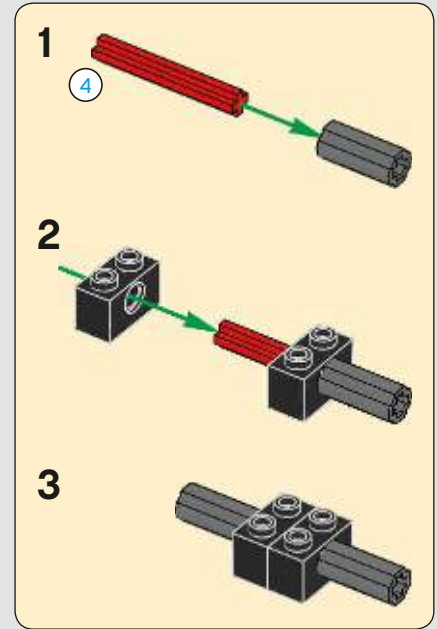
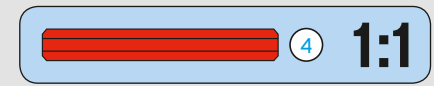

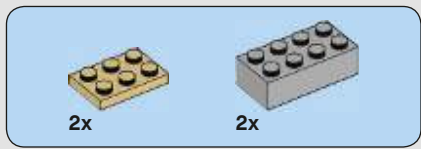

13

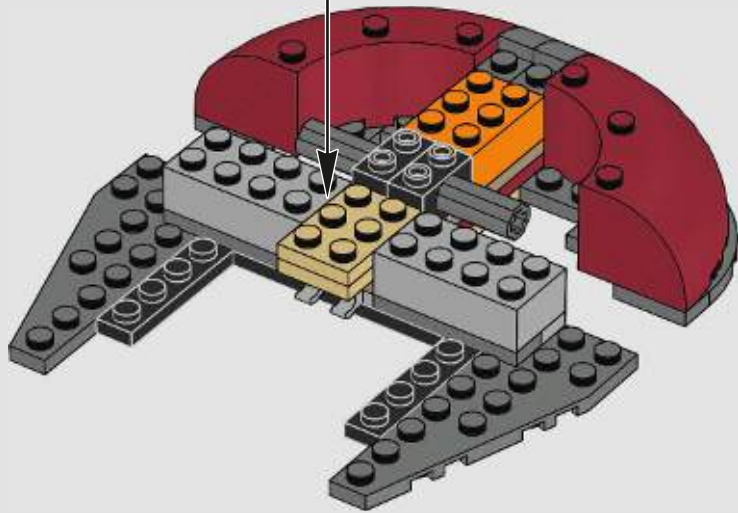
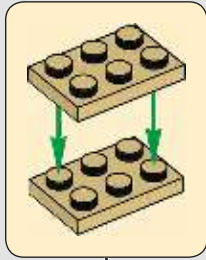

14

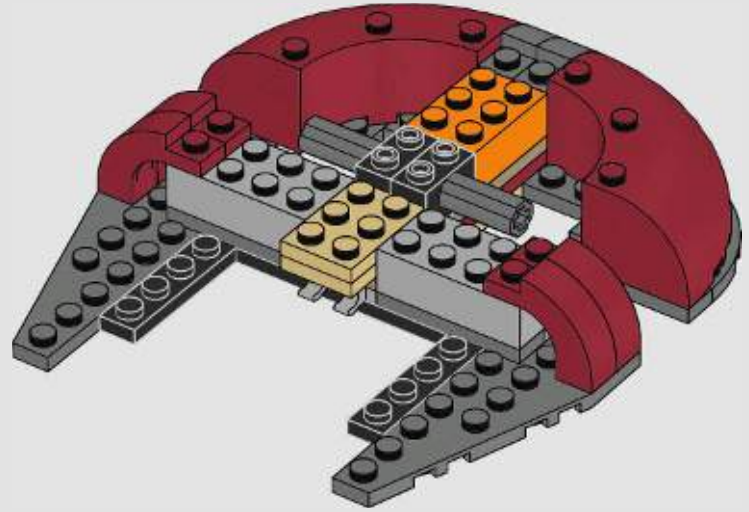

15

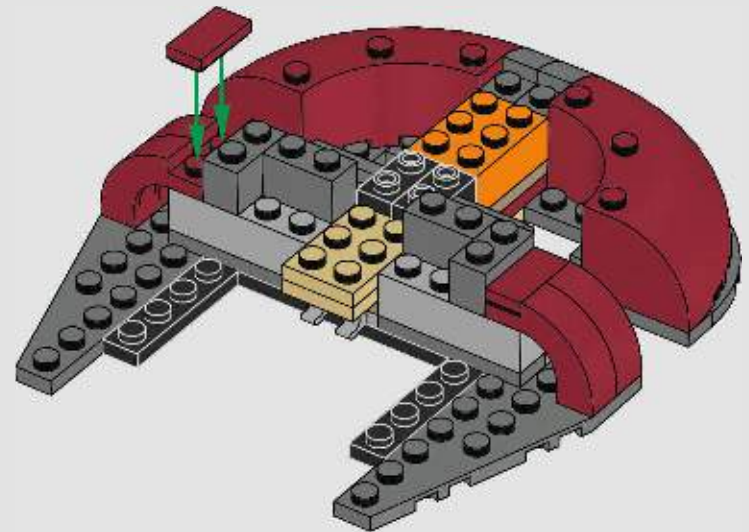

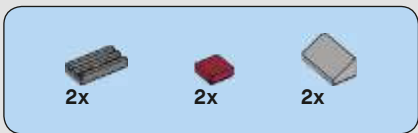

16

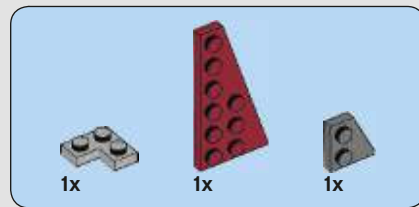
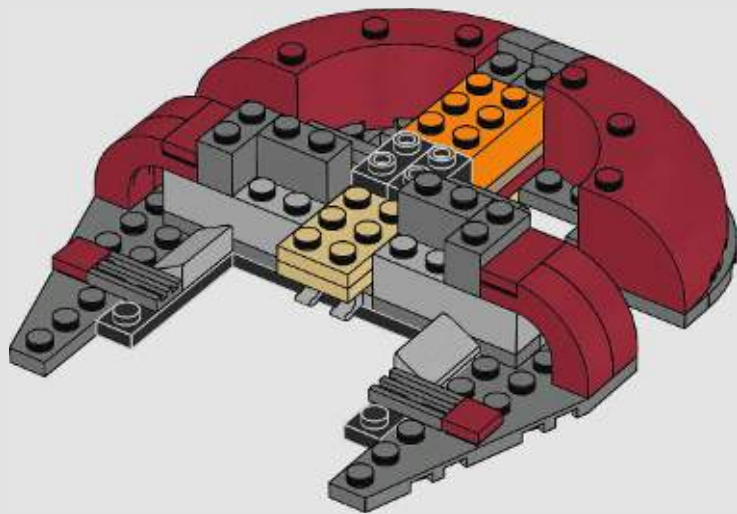

17

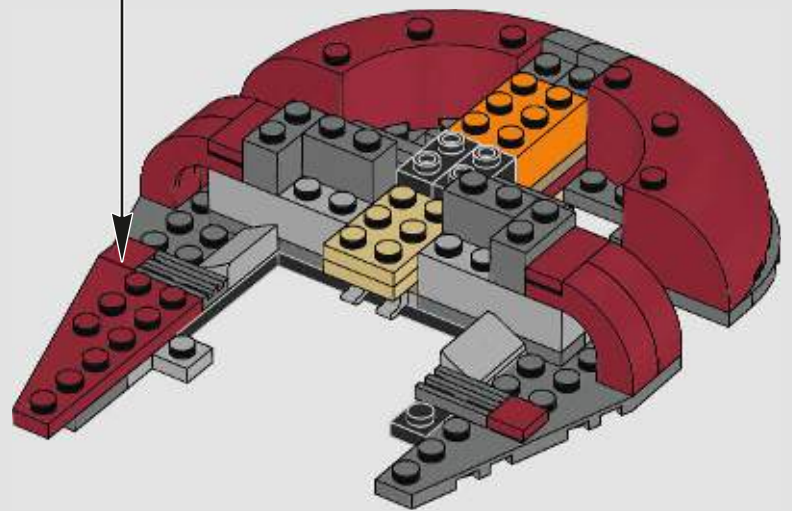
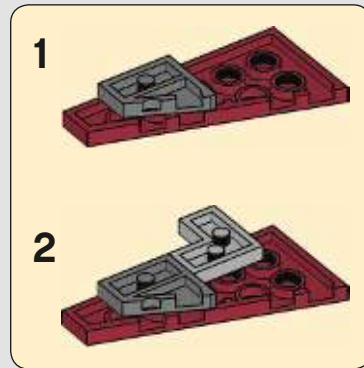

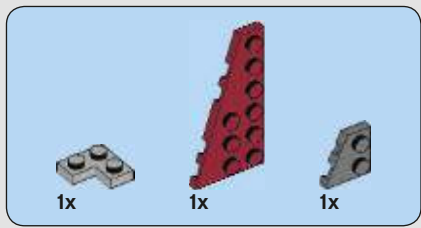

18

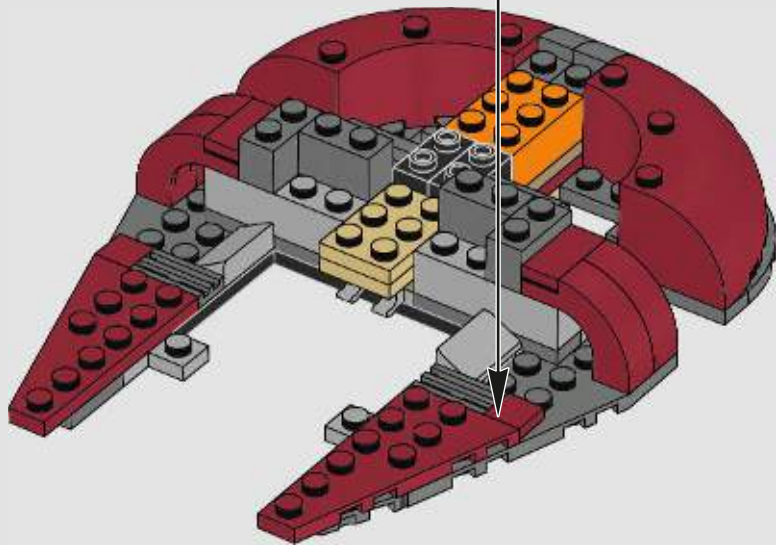
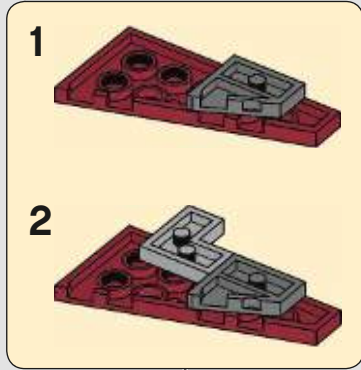

19

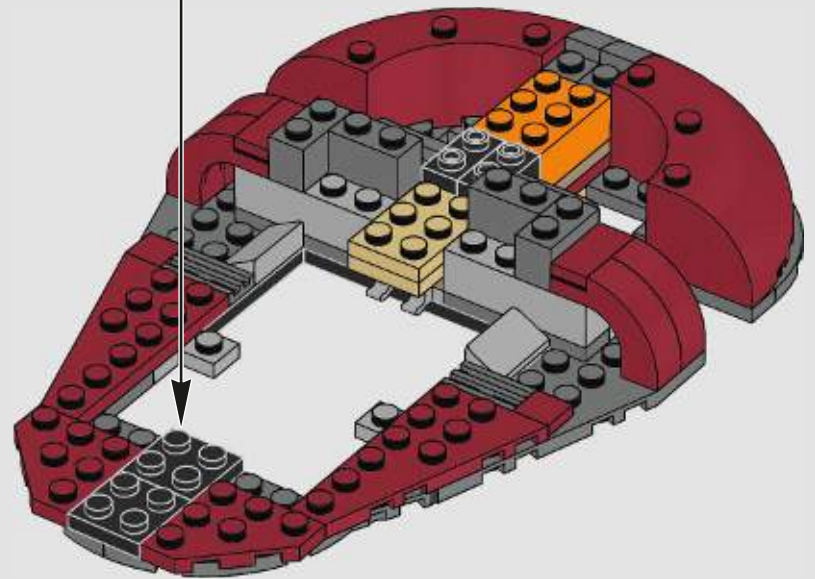
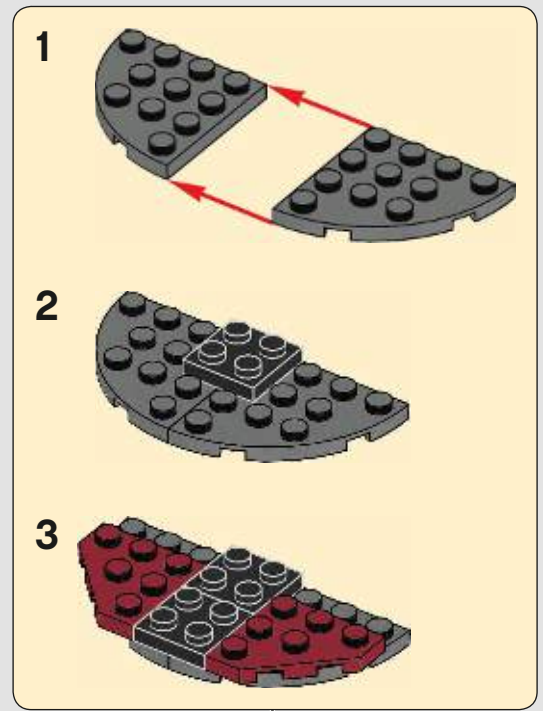



20

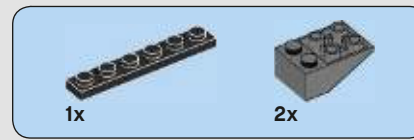
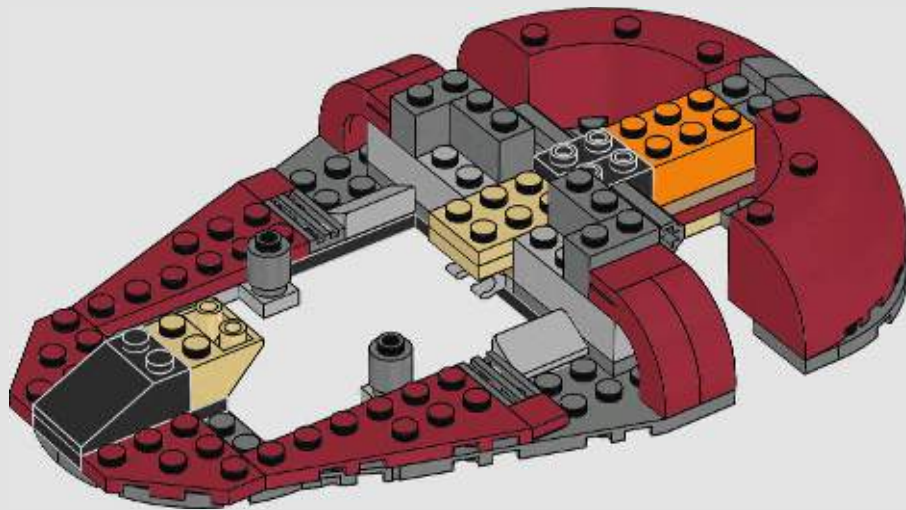

21

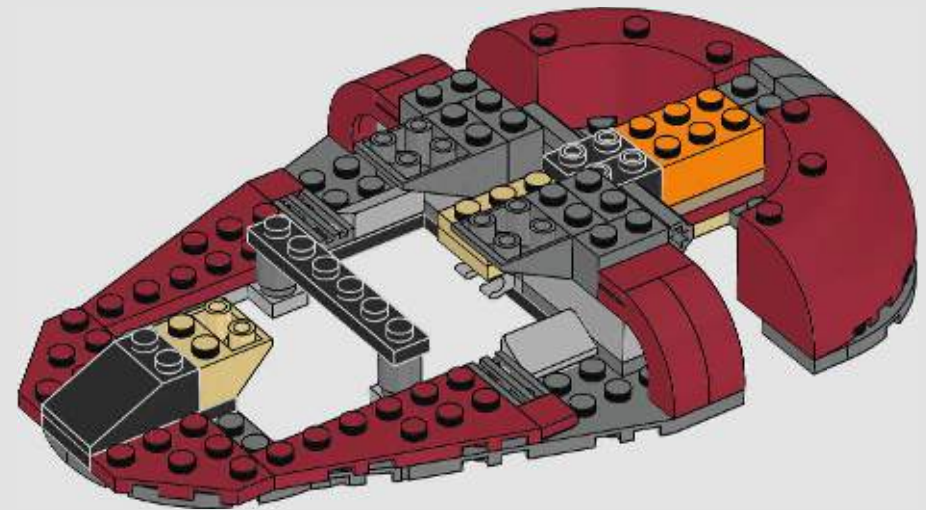

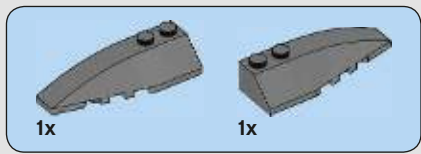

22

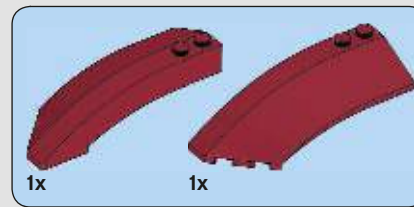
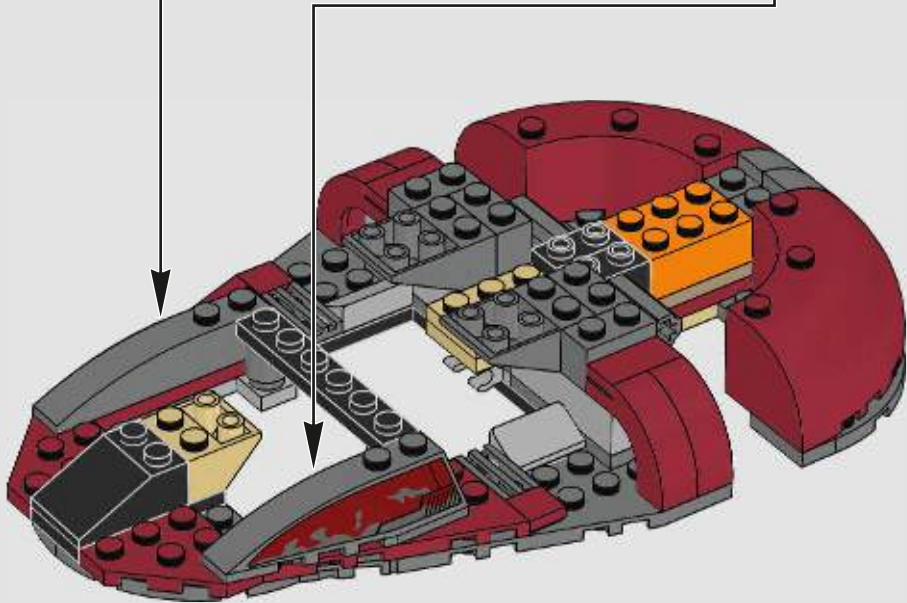
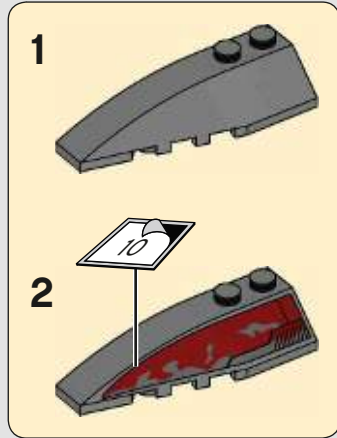
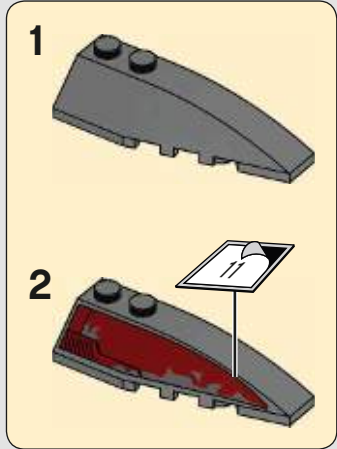

23

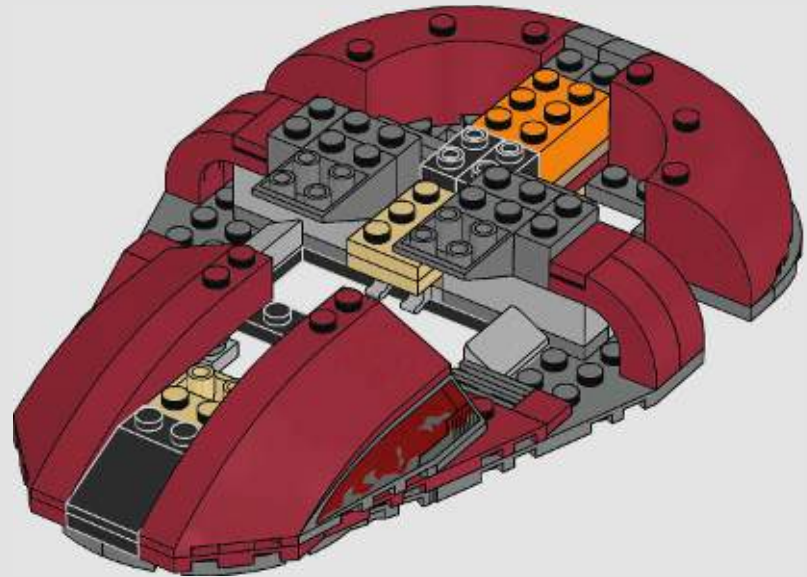

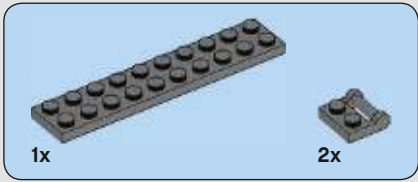
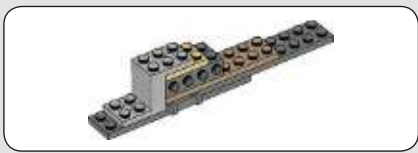

24

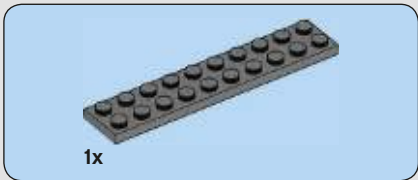
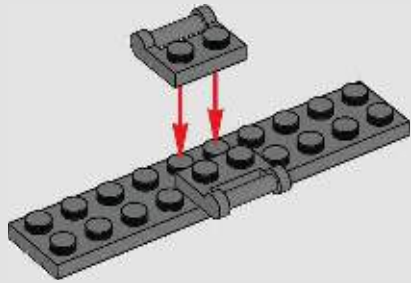

25

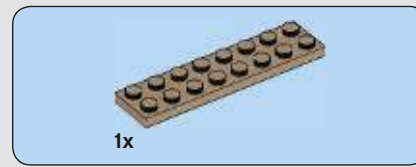
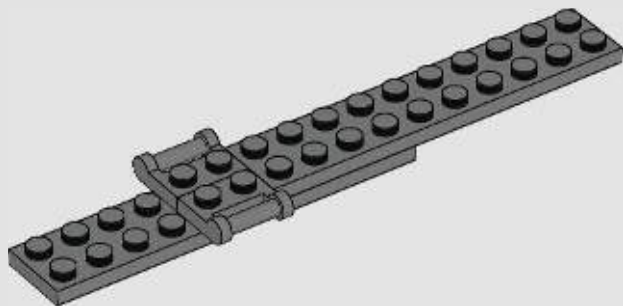

26

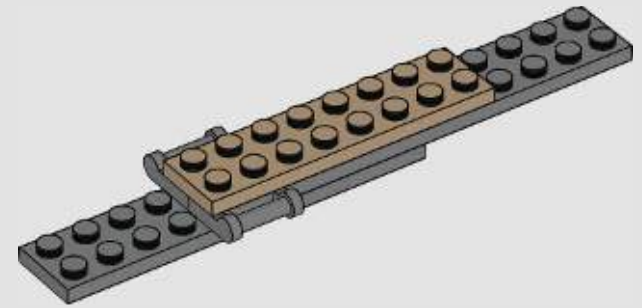

27

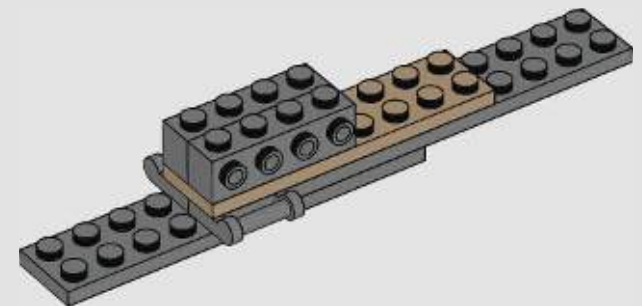



28

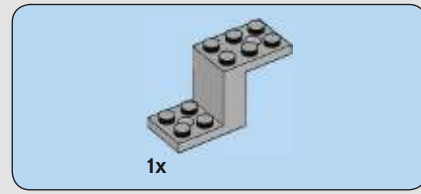
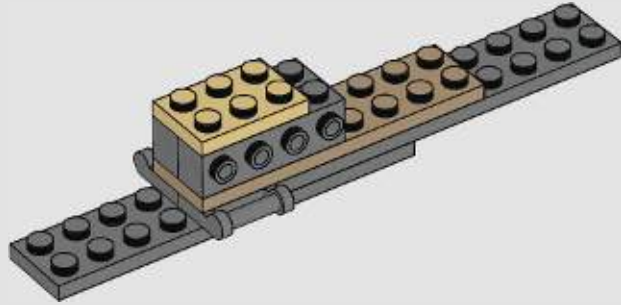

29

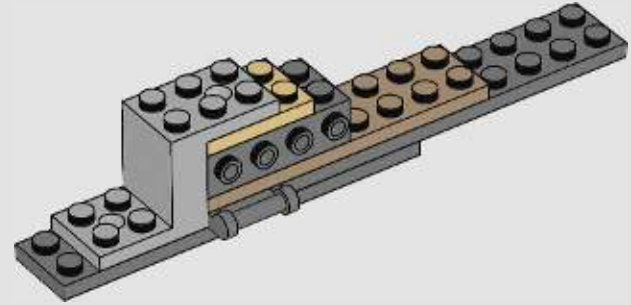

30

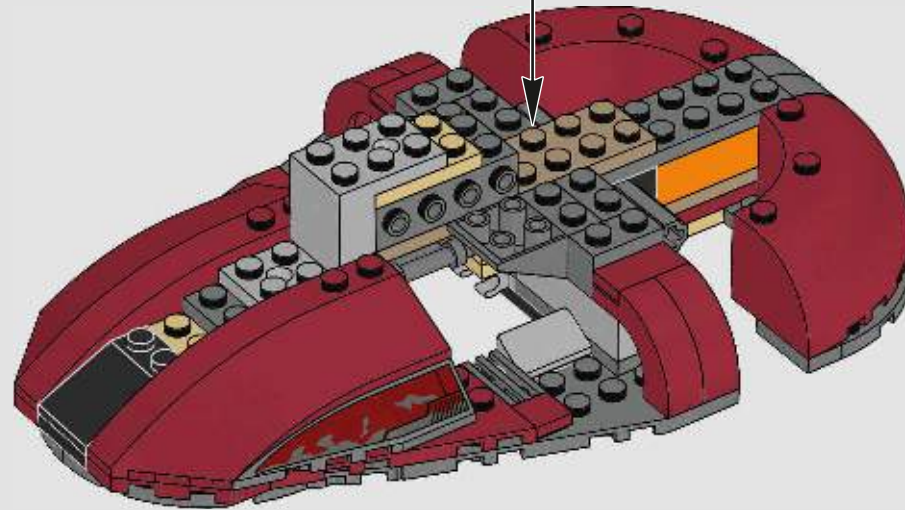



31

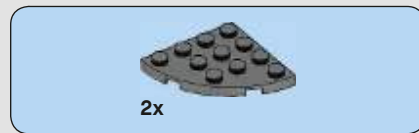
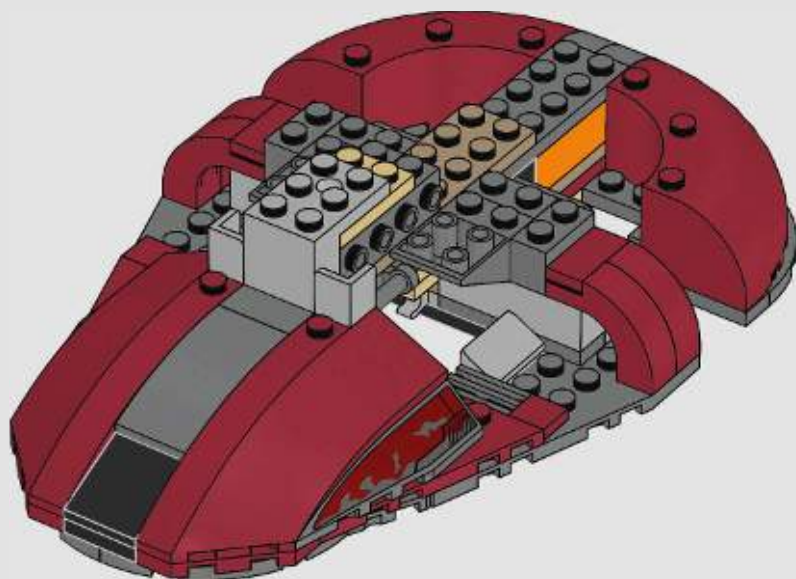

32

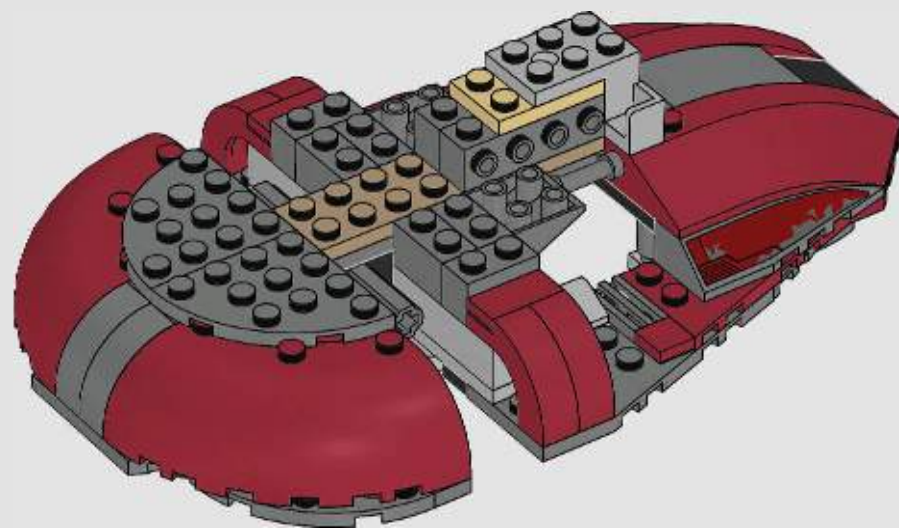
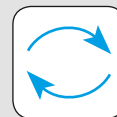

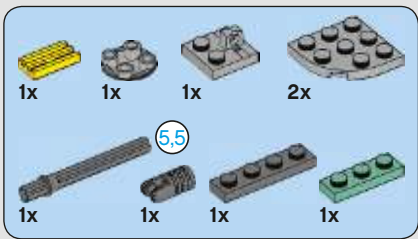

34

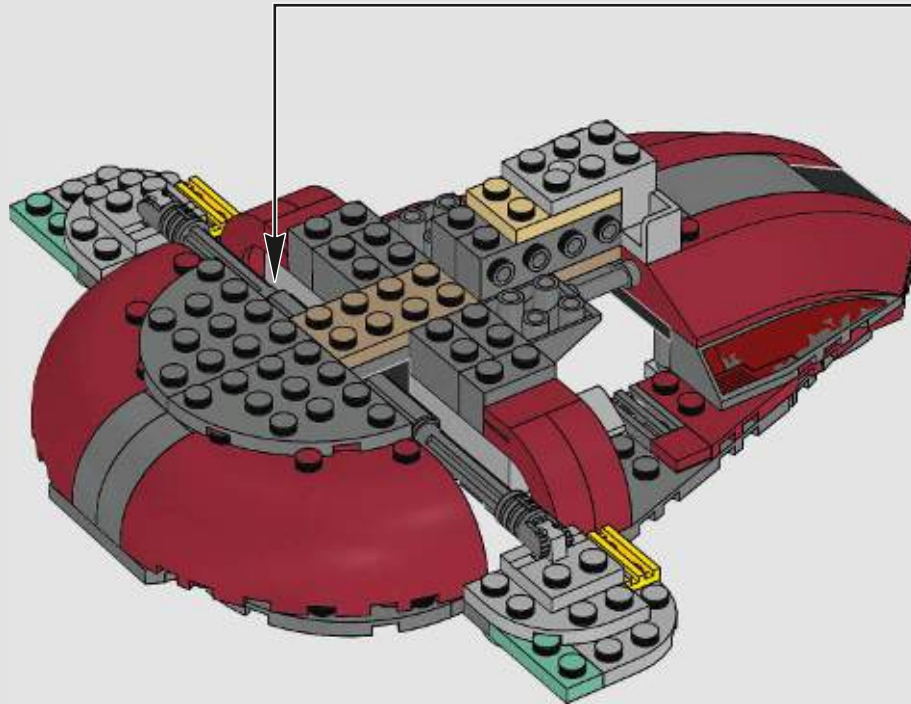
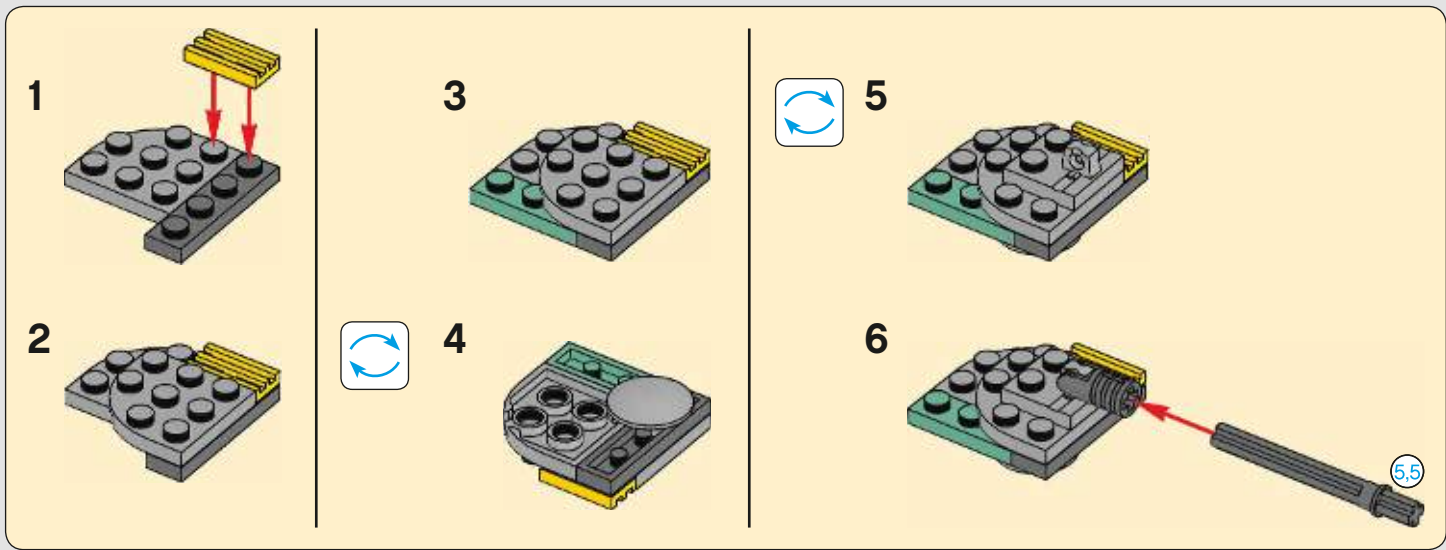

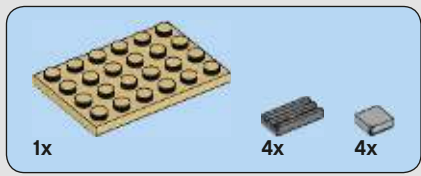

35

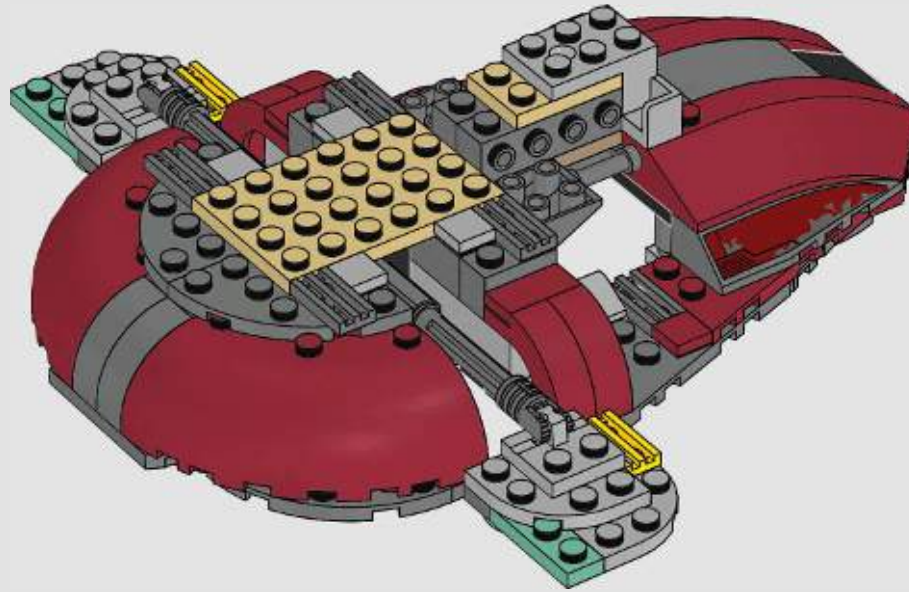

36

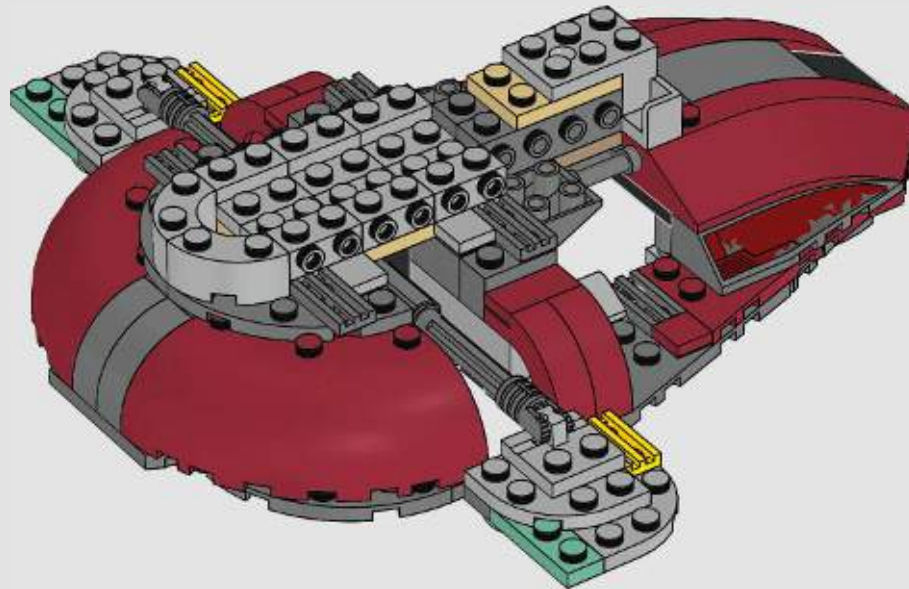



37

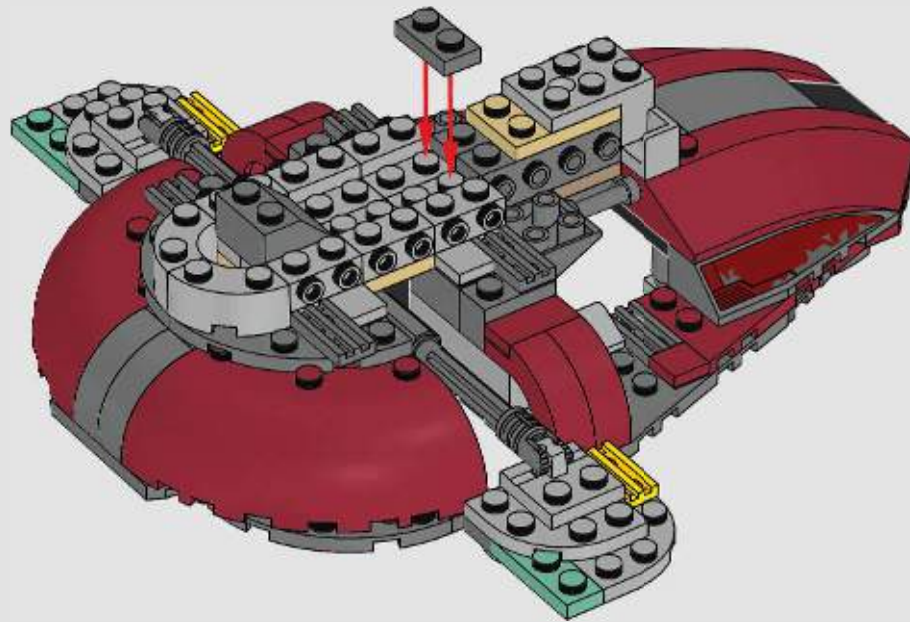

38

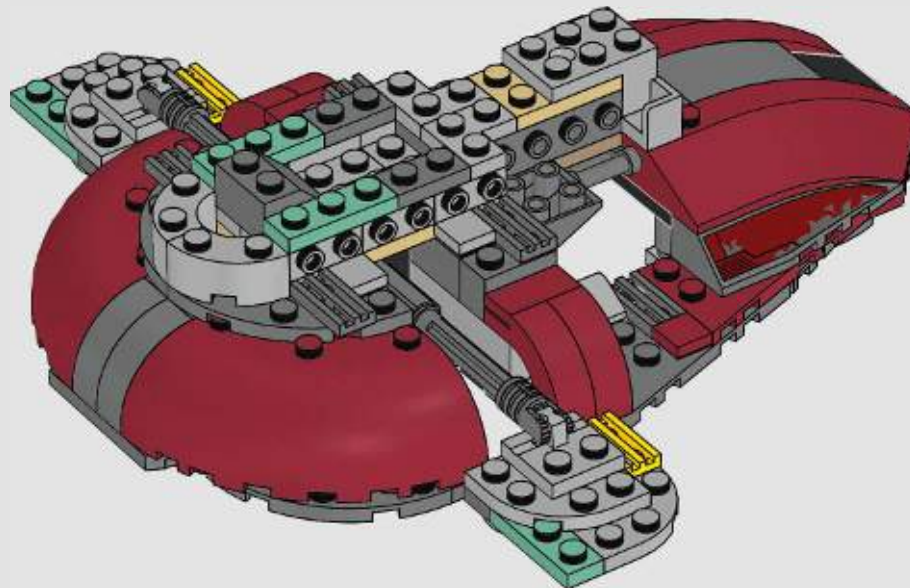



39

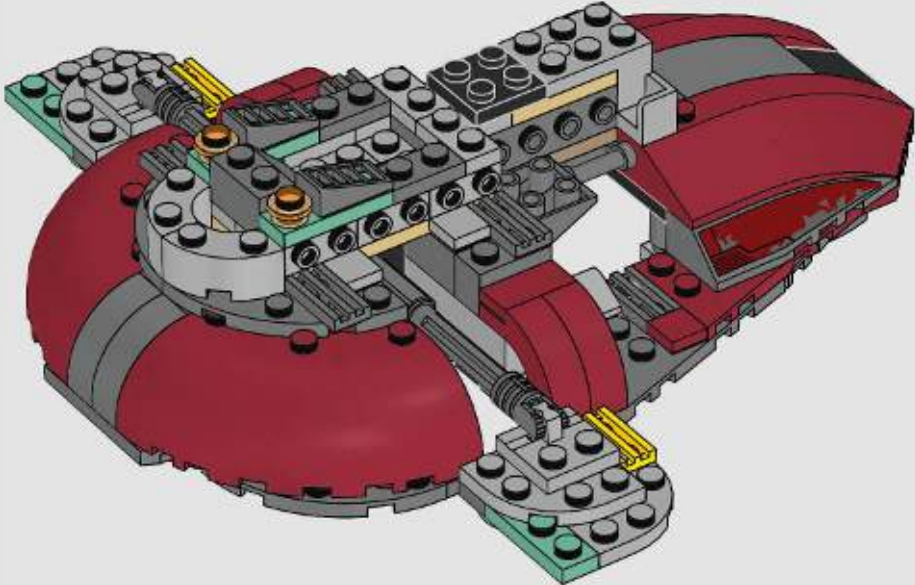

40

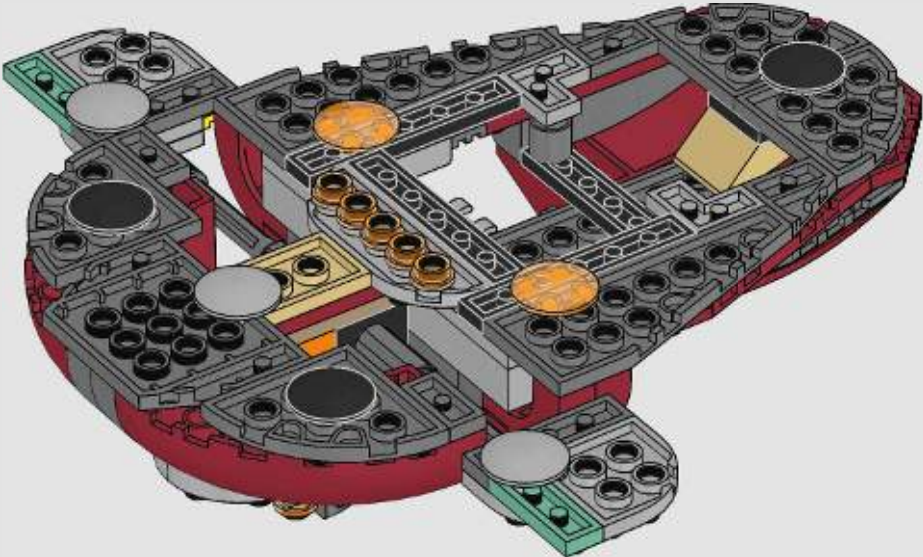



41

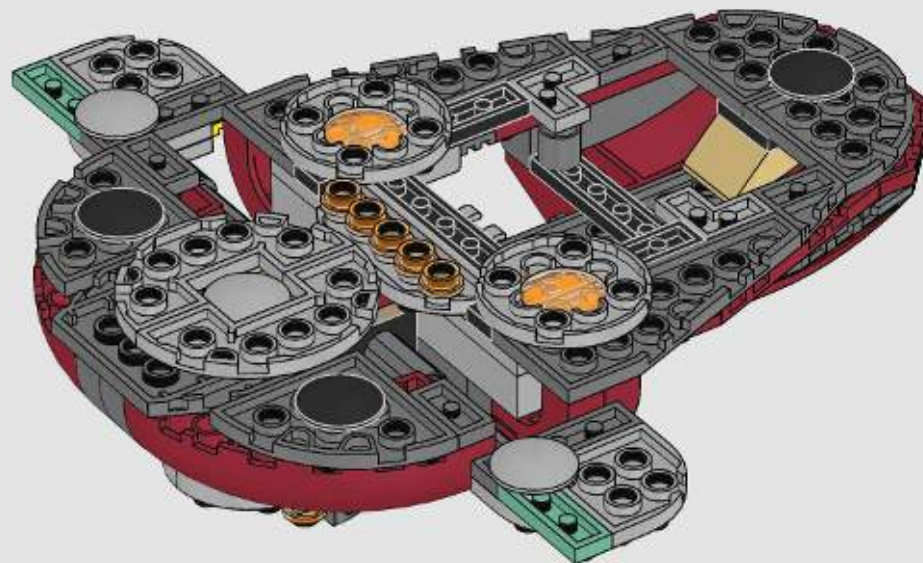

42

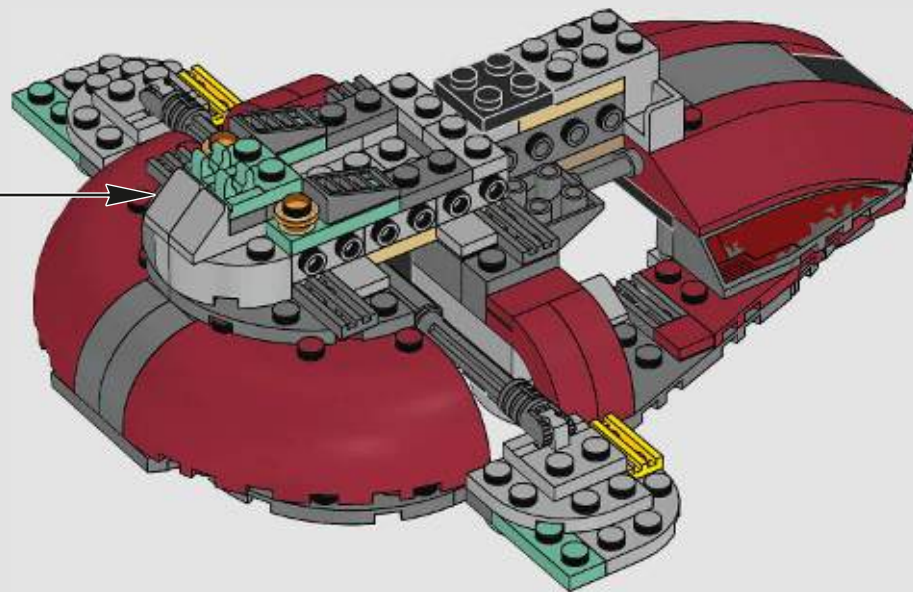
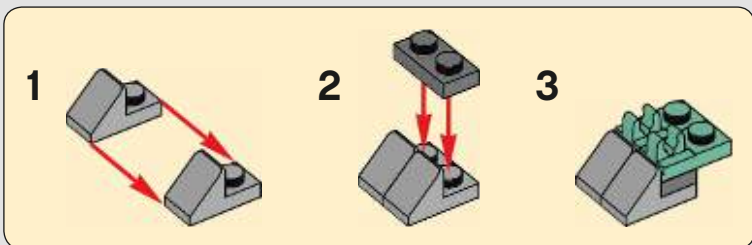
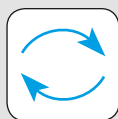

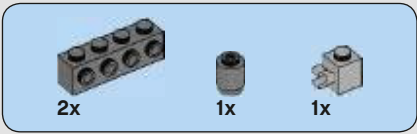

43

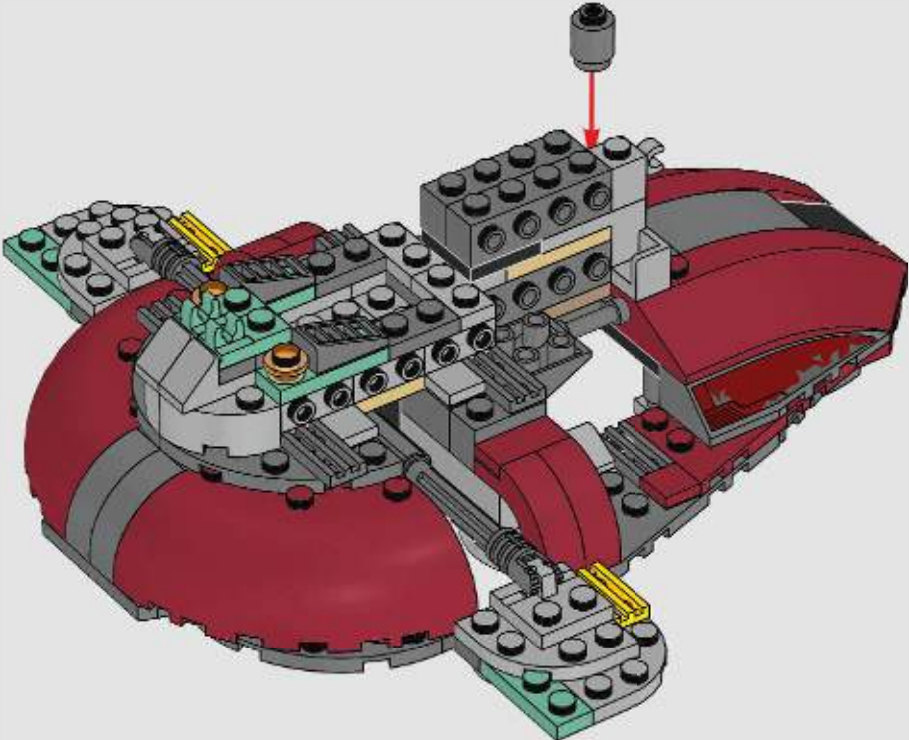

44

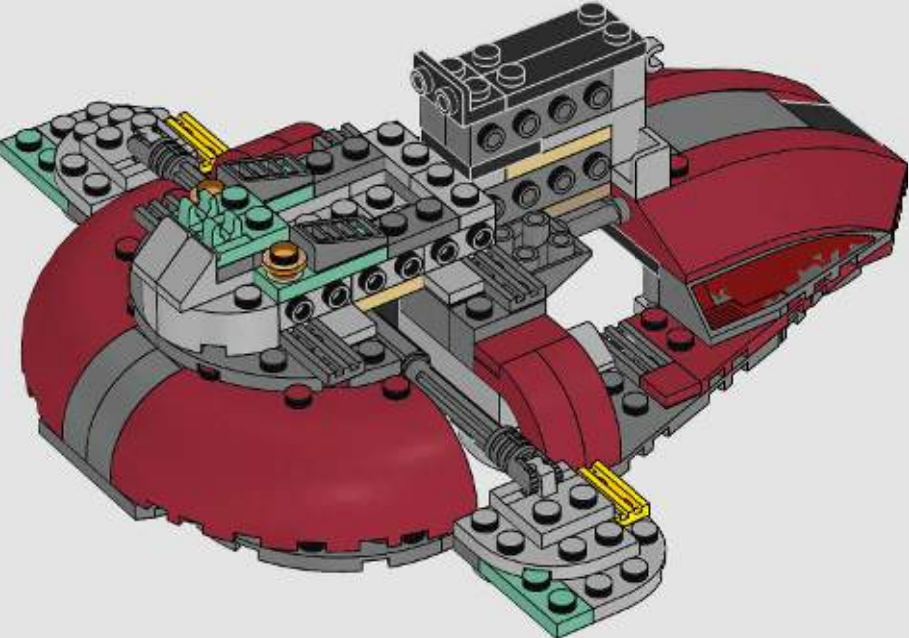



45

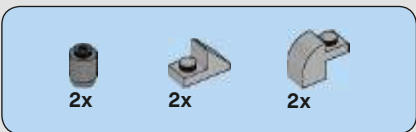
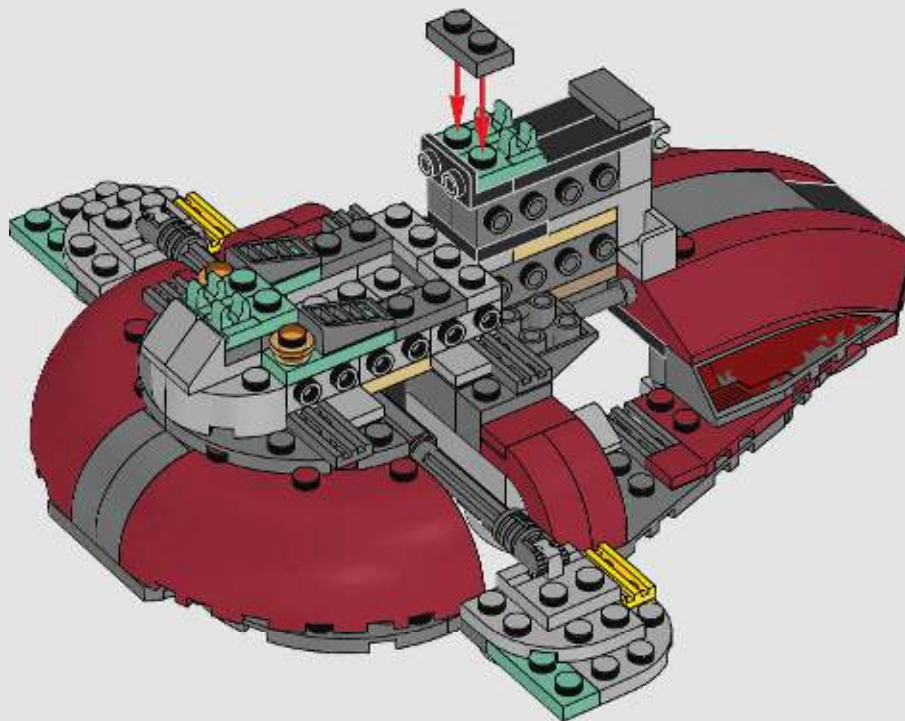

46

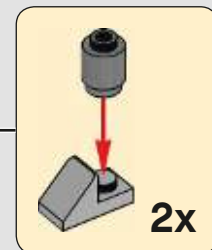
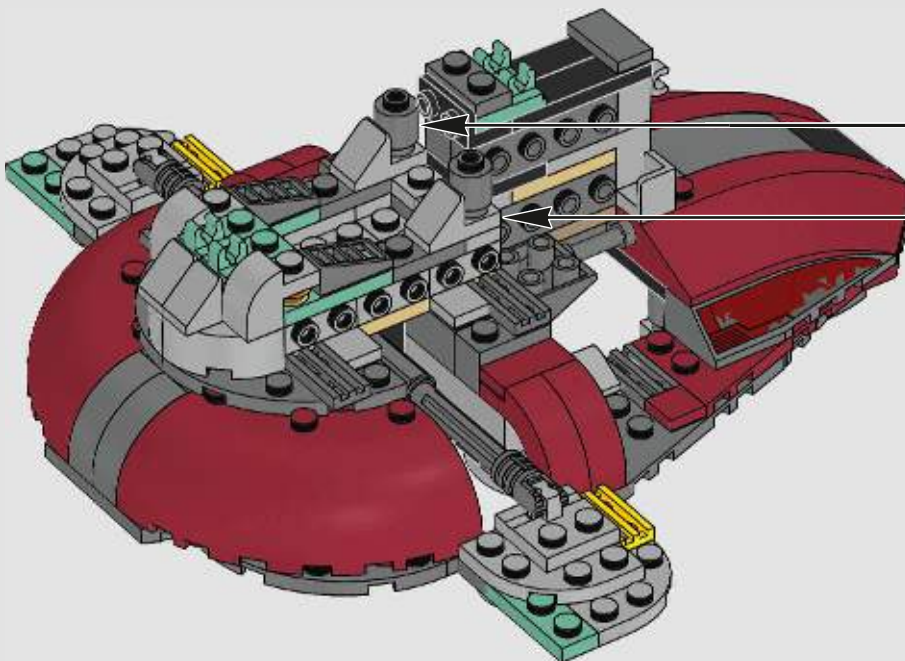

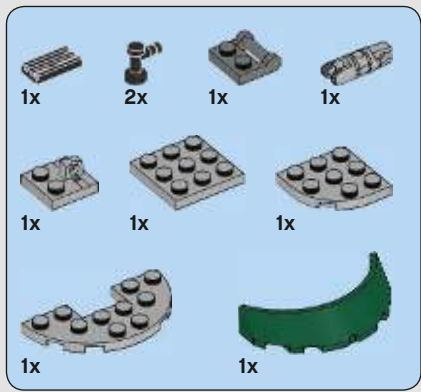

47

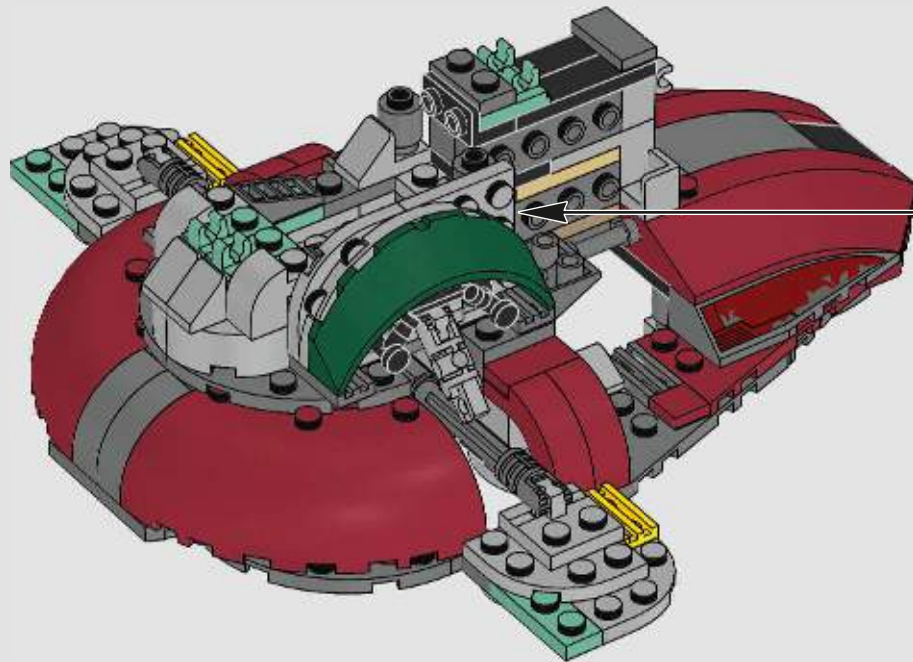
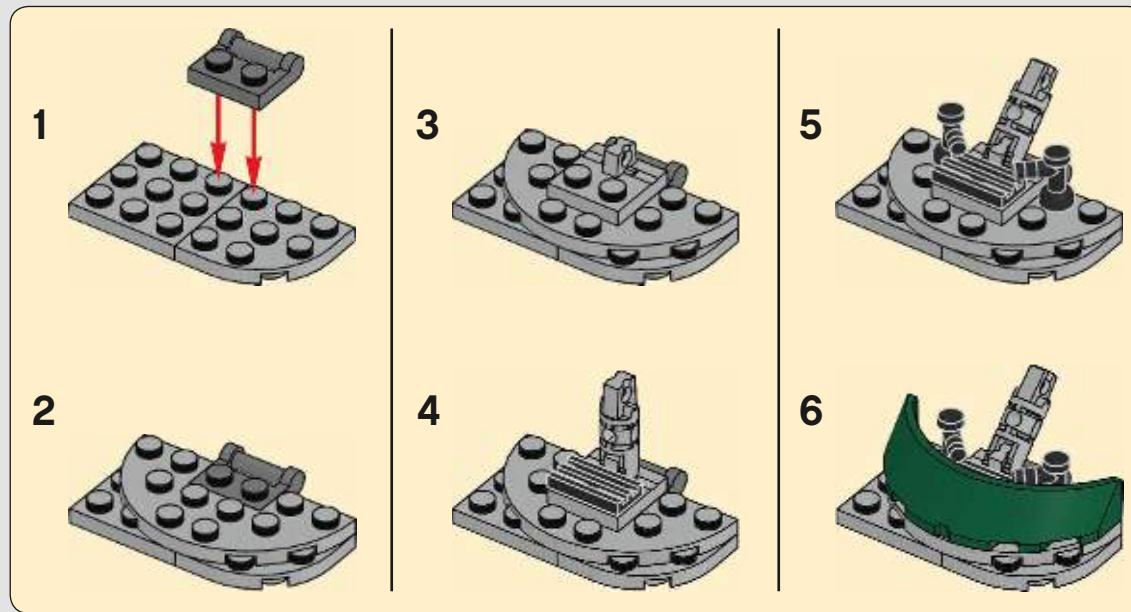



48

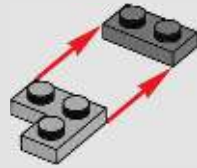

49



50



51

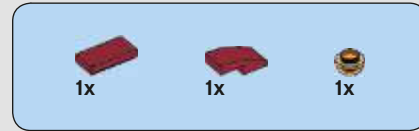

52



53

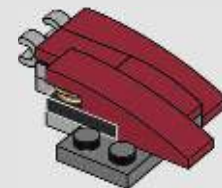

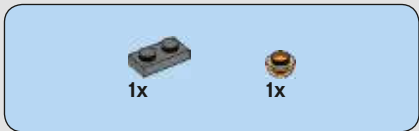

54

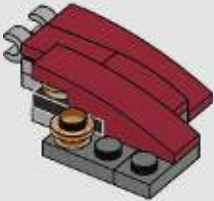

55

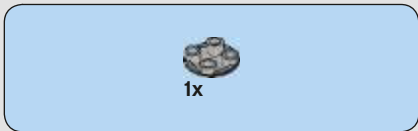
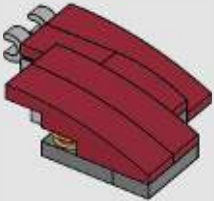

56



57

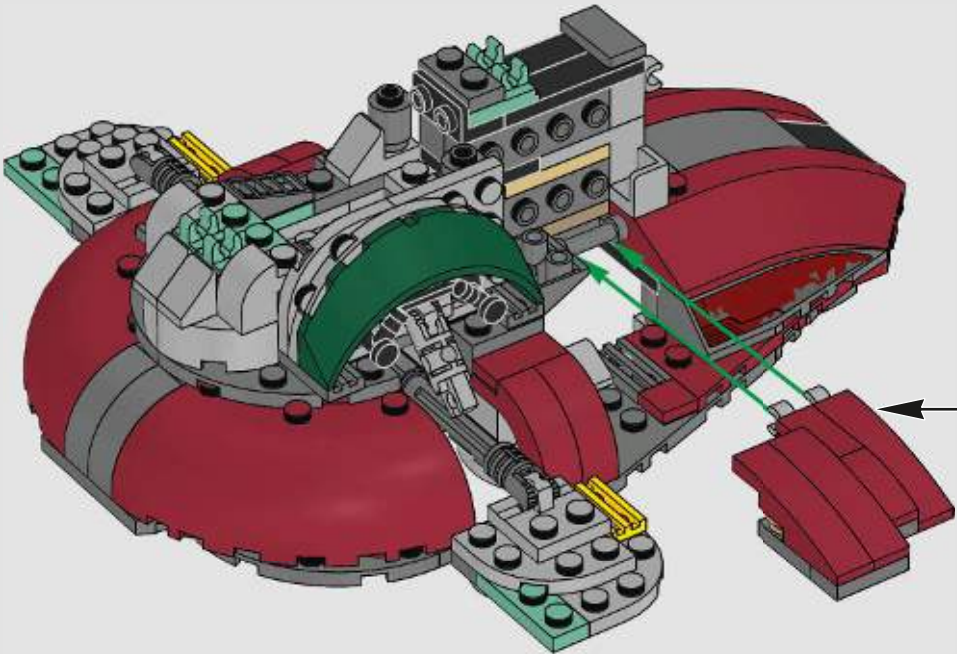

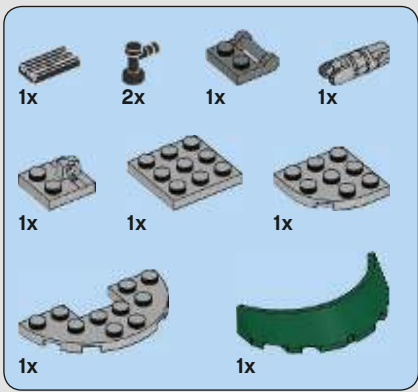

58

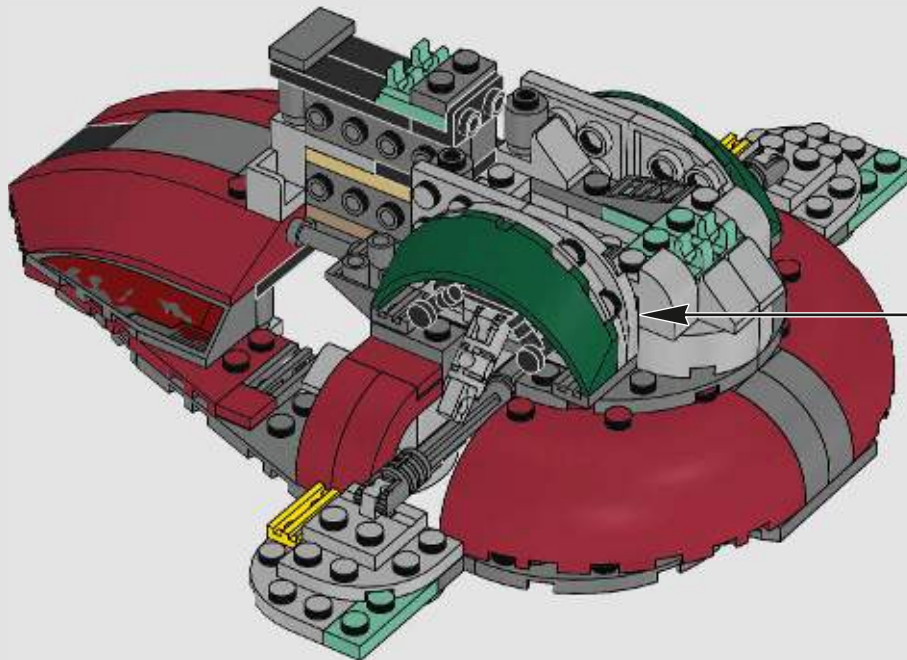
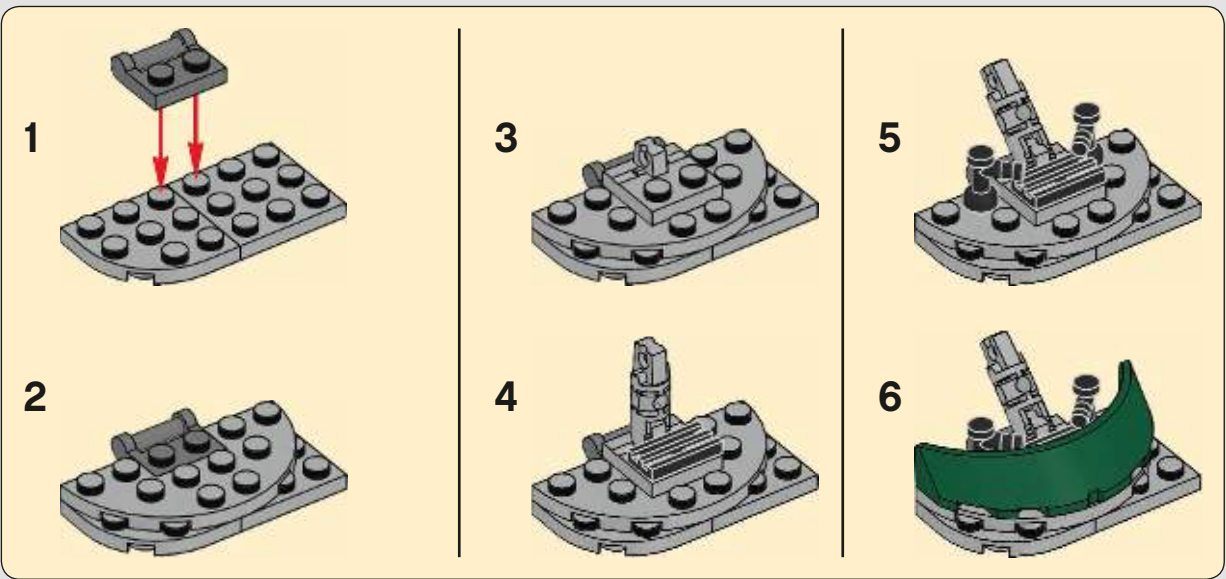



59

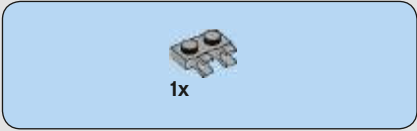
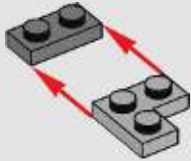

60

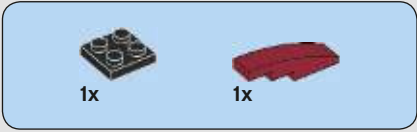

61



62

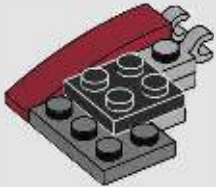

63



64

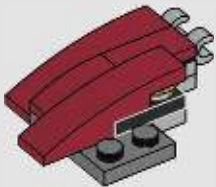

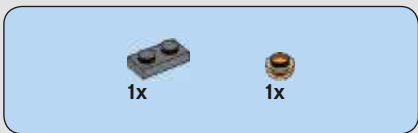

65

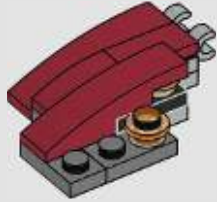

66

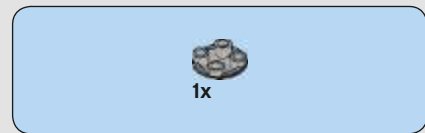
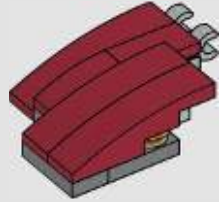

67

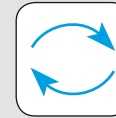

68

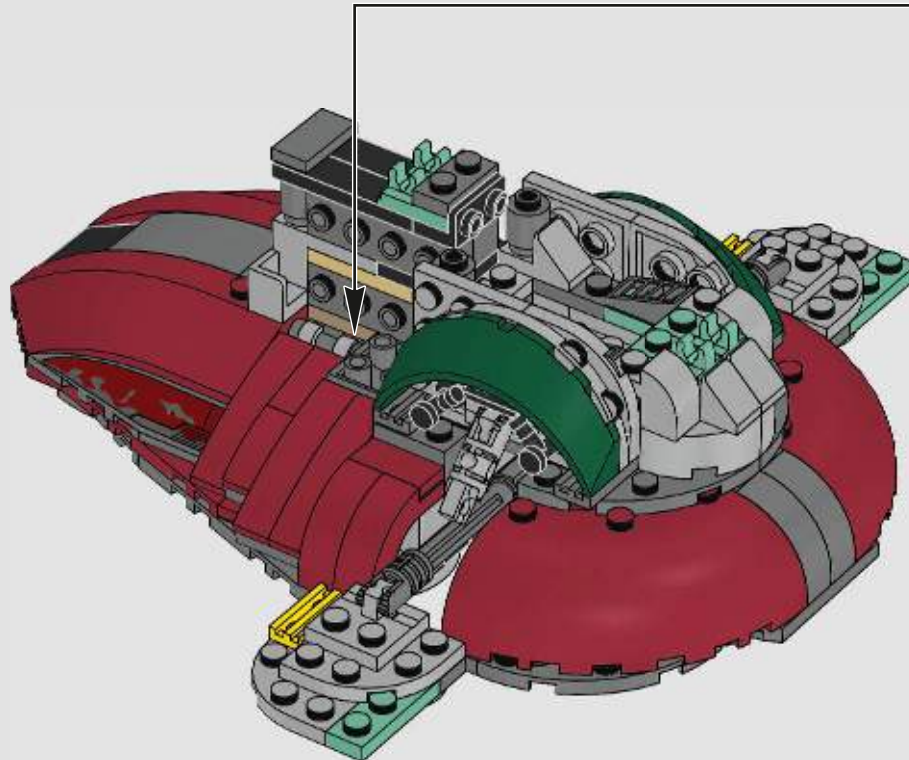

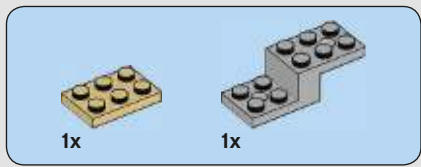

69

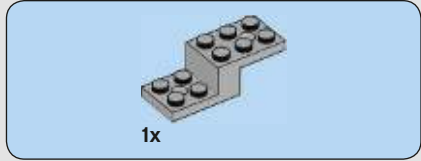
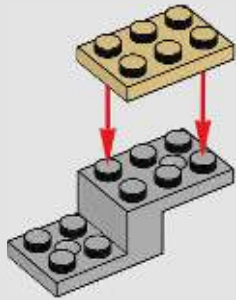

70

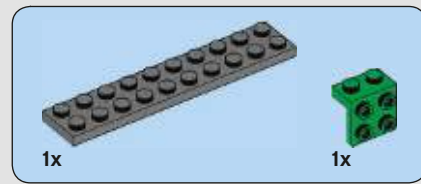
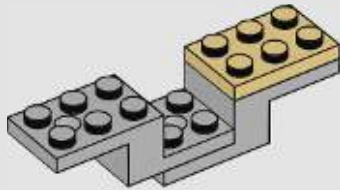

71

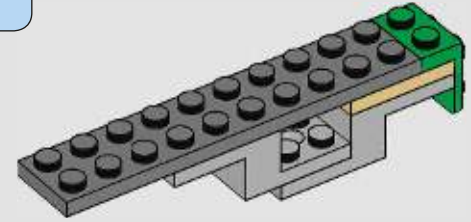

72

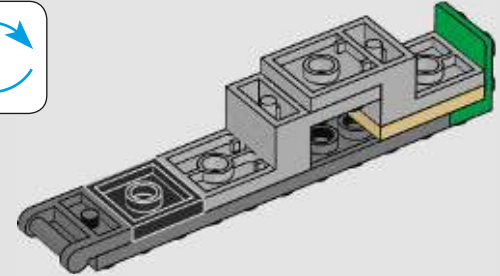
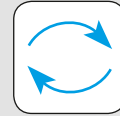

73

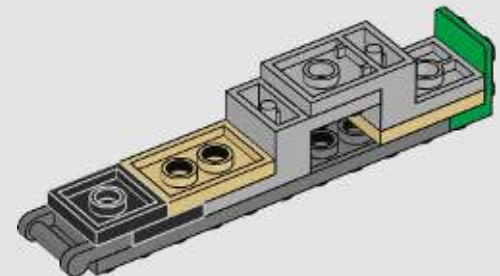

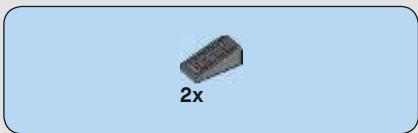

74

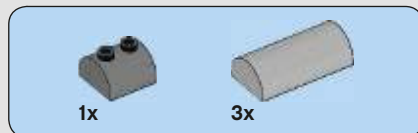
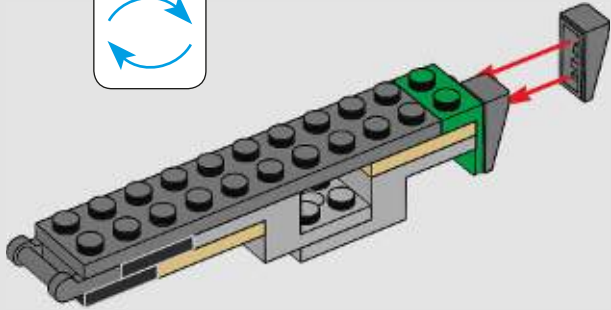

75

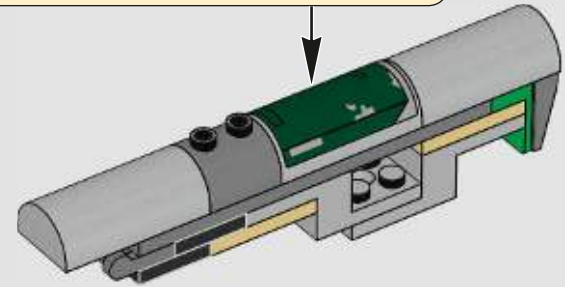
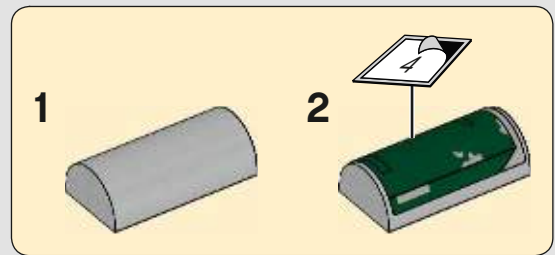

76

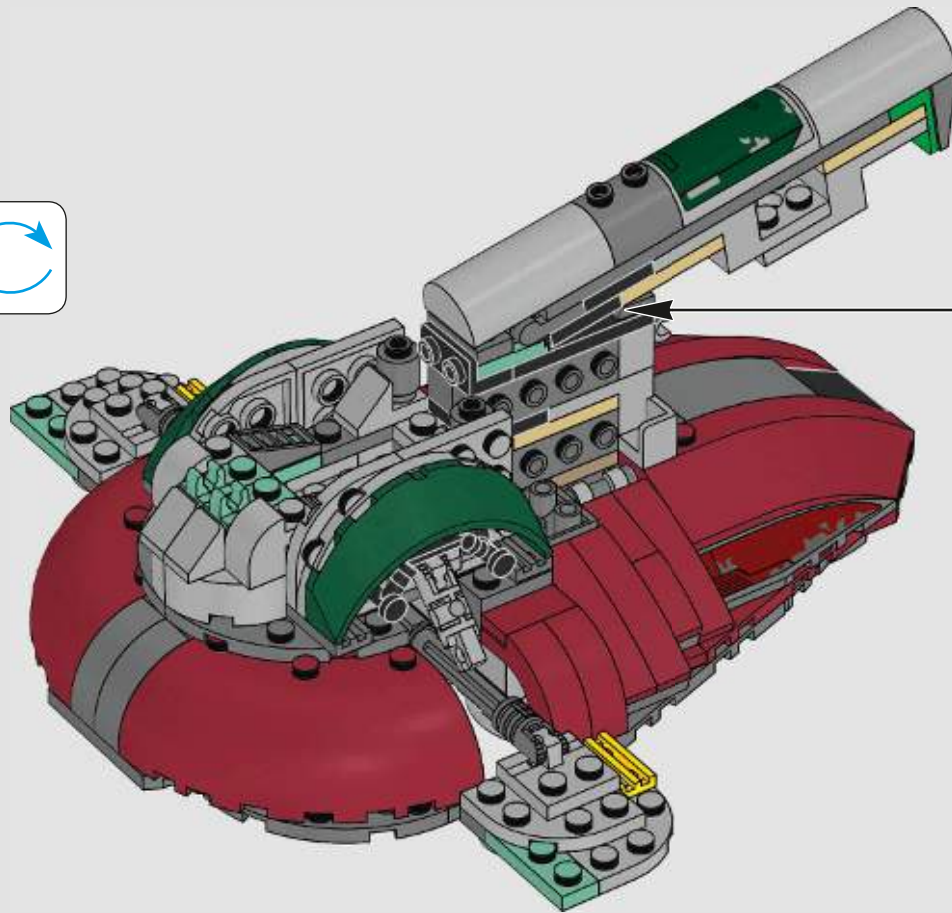
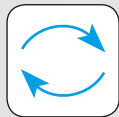

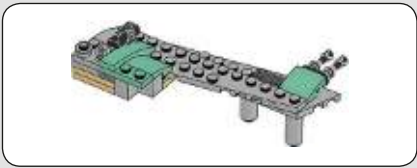

77



78

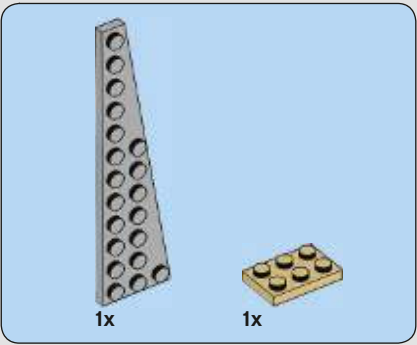
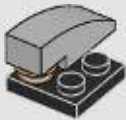

79

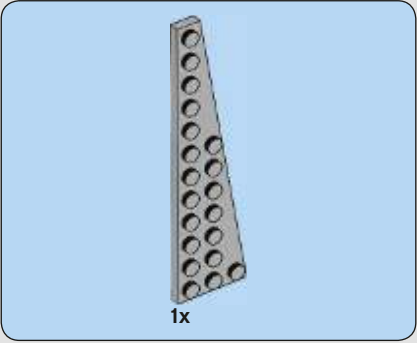
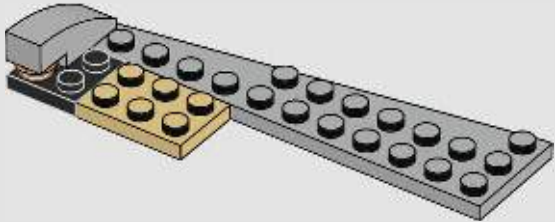

80

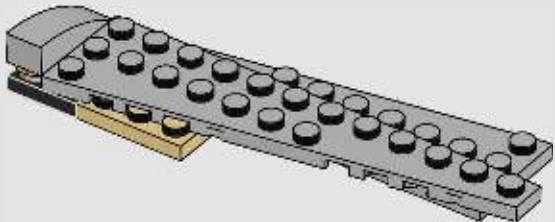



81

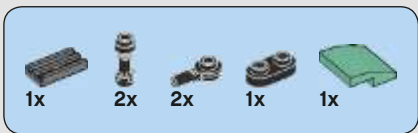
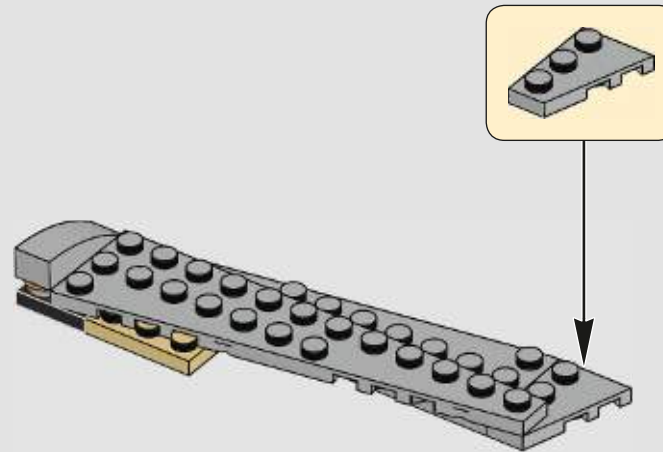

82

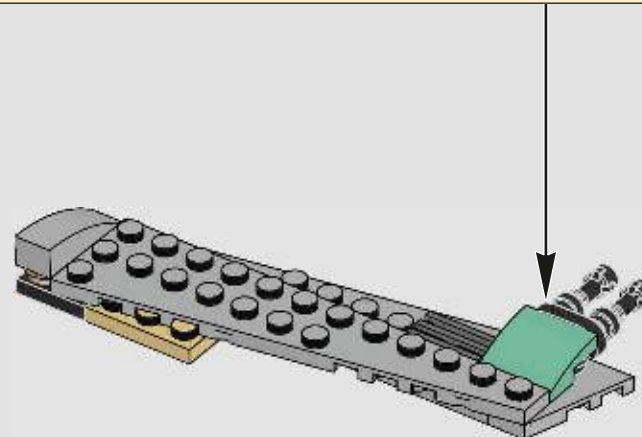
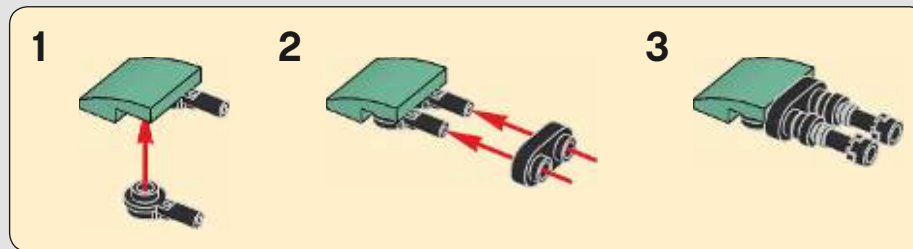

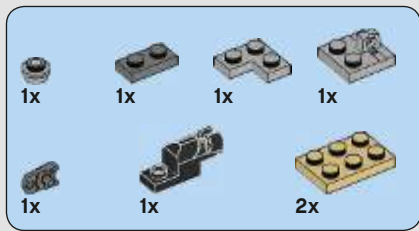

83

1

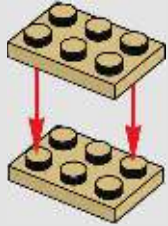

2

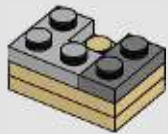

3

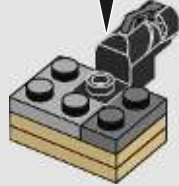

4

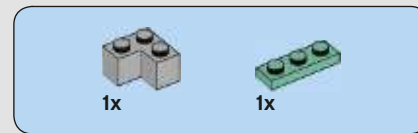
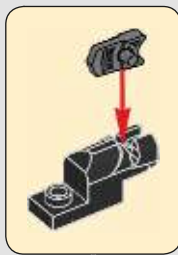
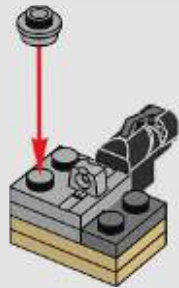

84

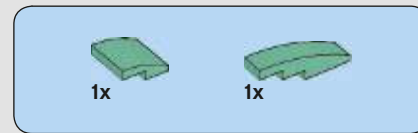
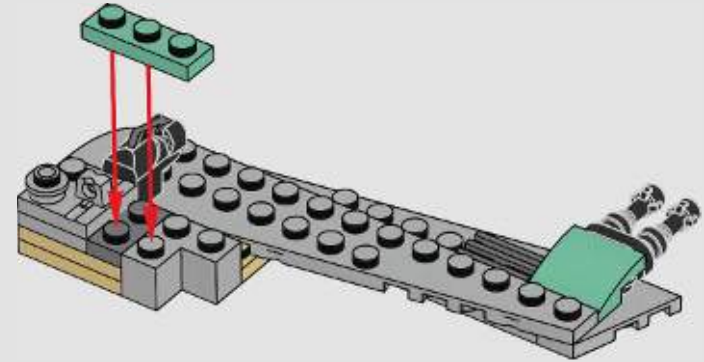

85

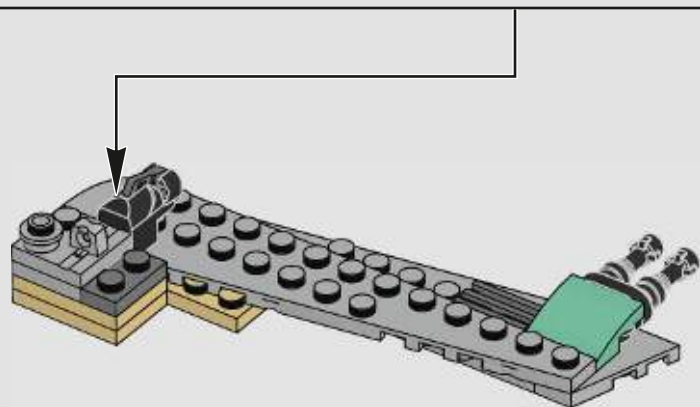
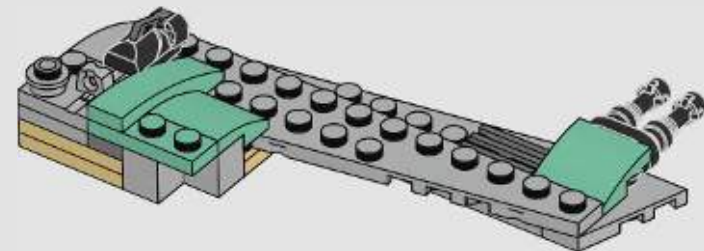



86

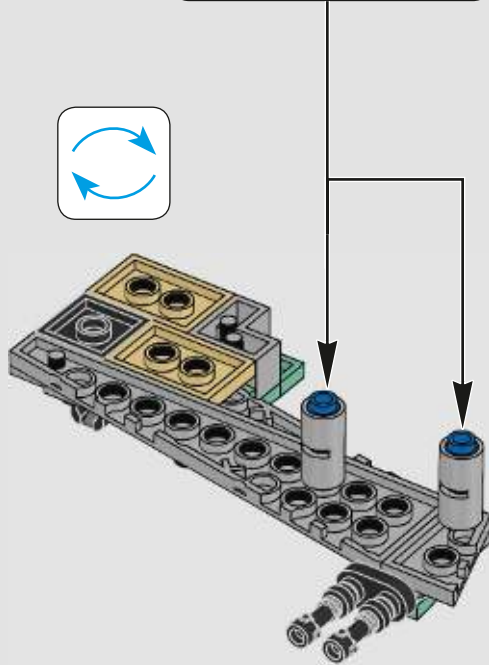
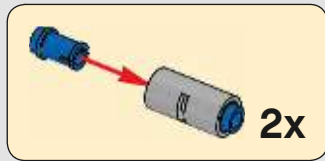

87

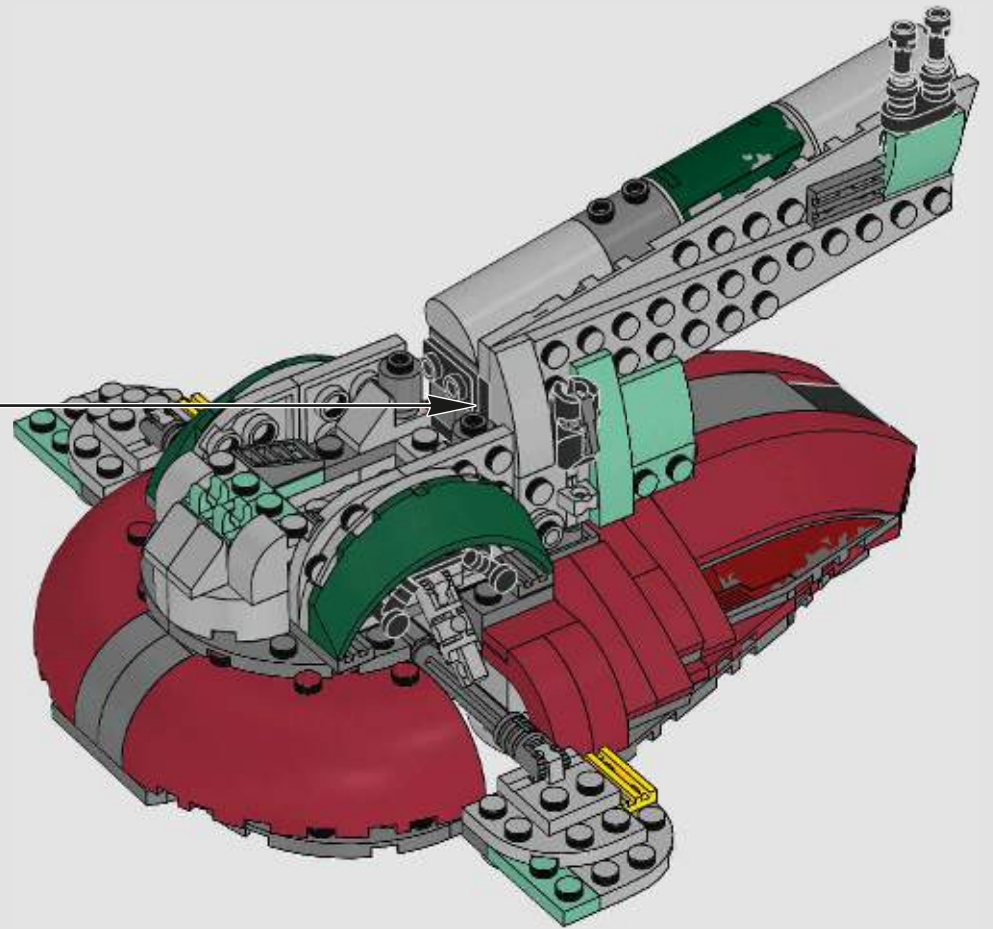



88

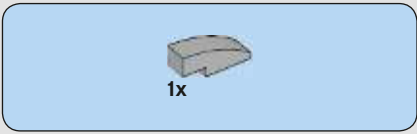

89

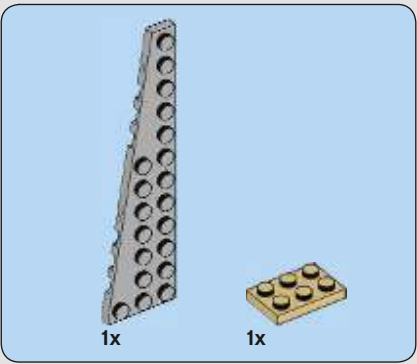

90

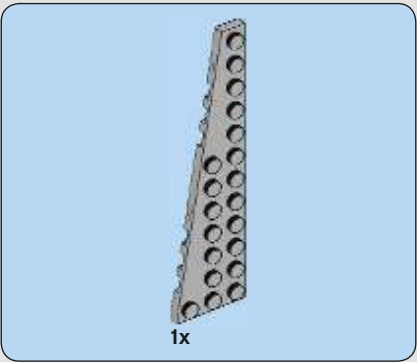
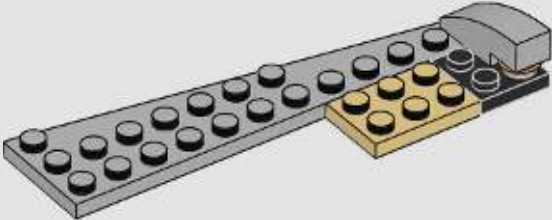

91

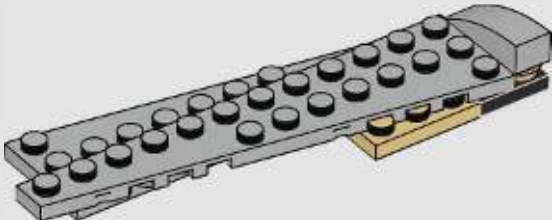



92

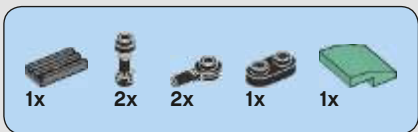
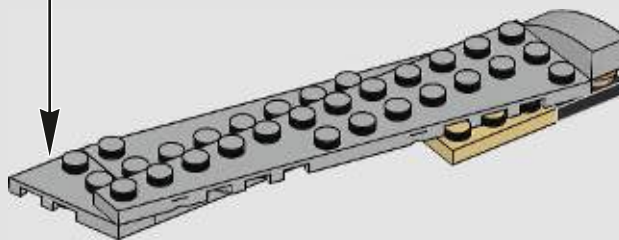
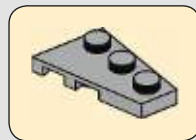

93

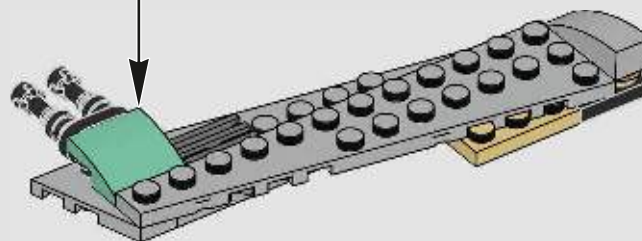
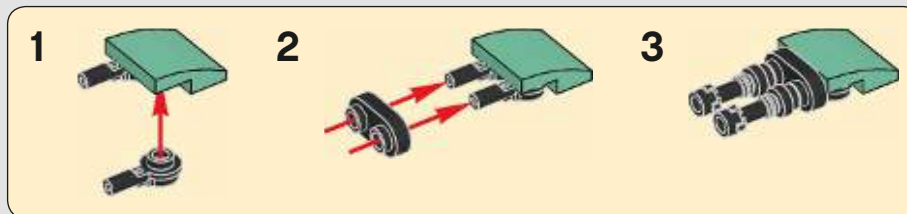

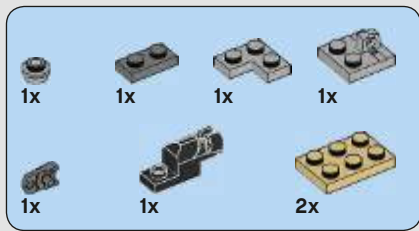

94

1

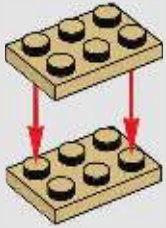

2

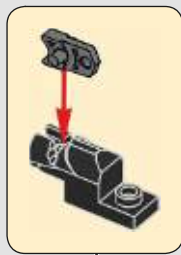
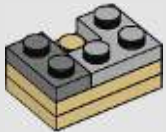

3

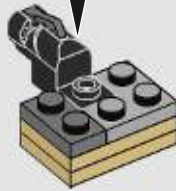

4

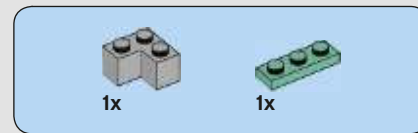
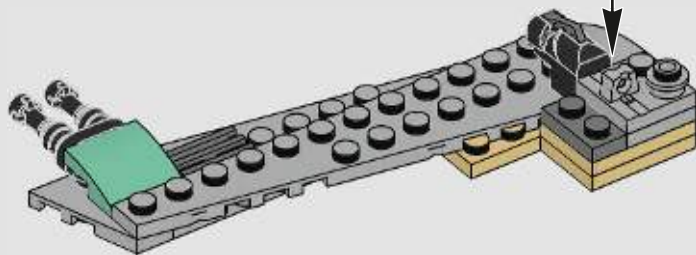
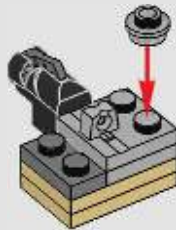

95

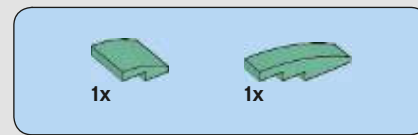
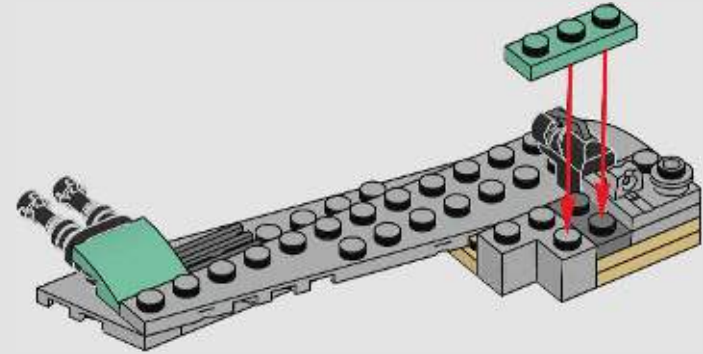

96

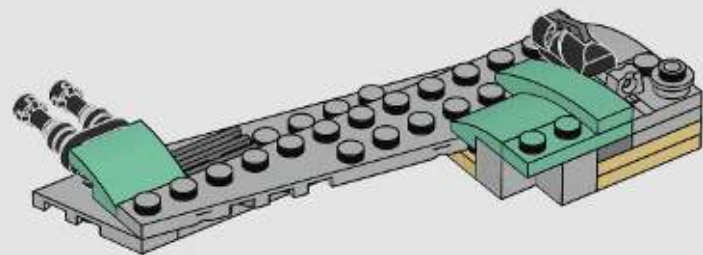

97

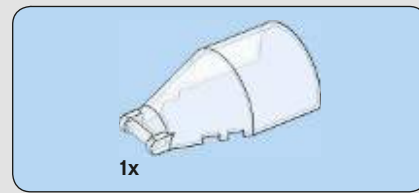
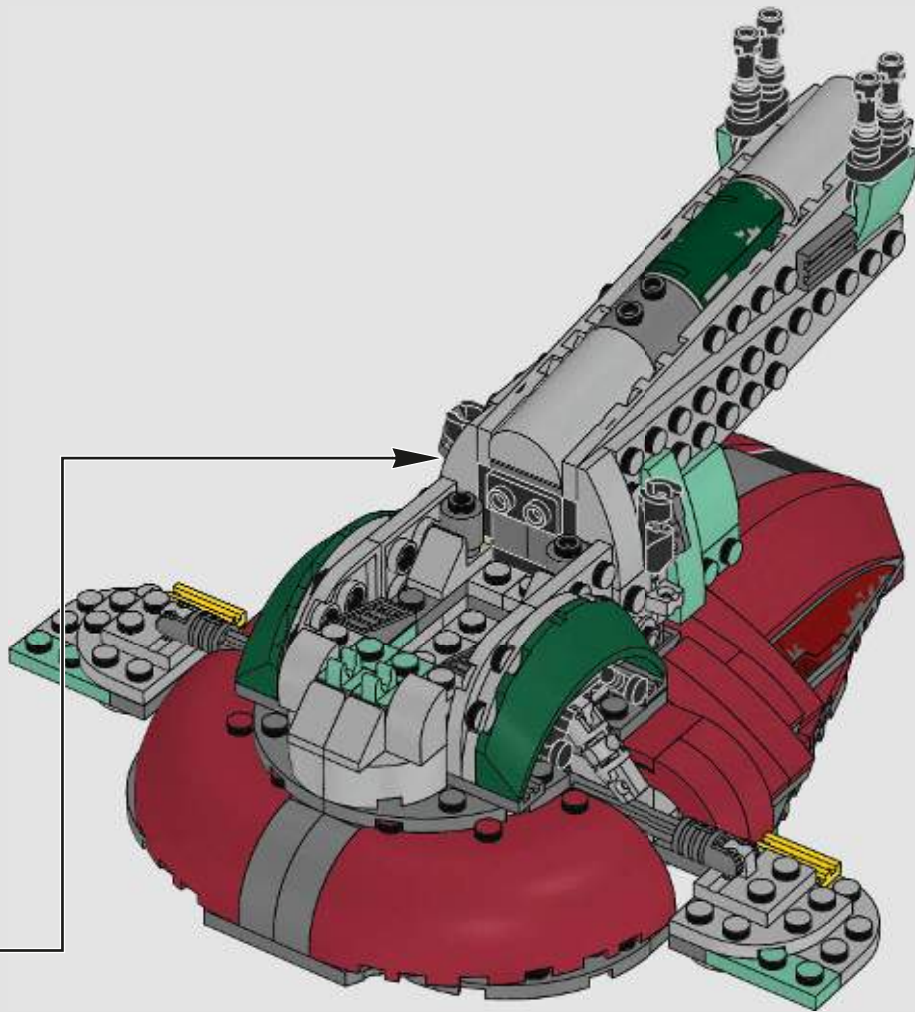

98

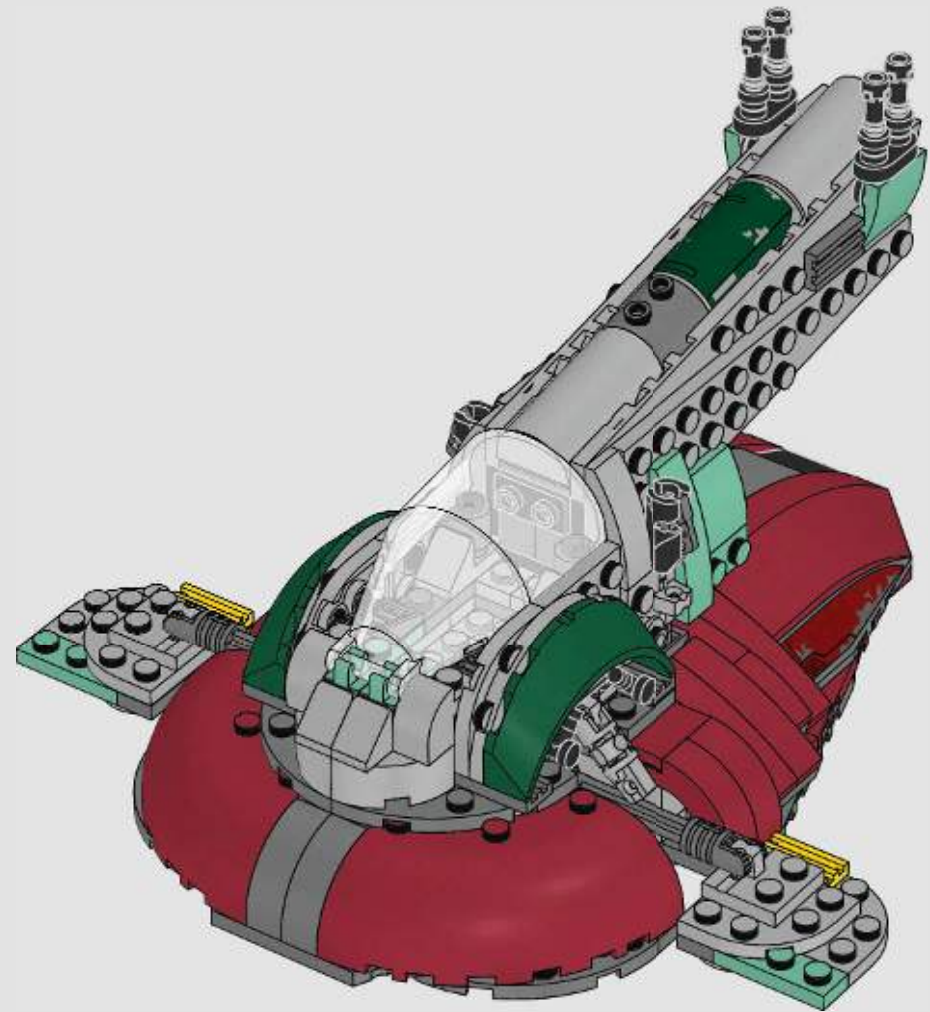

4x



99

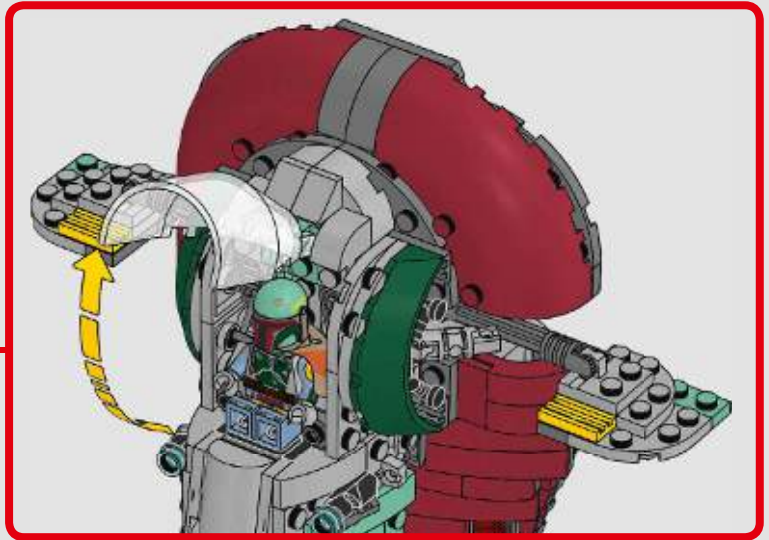
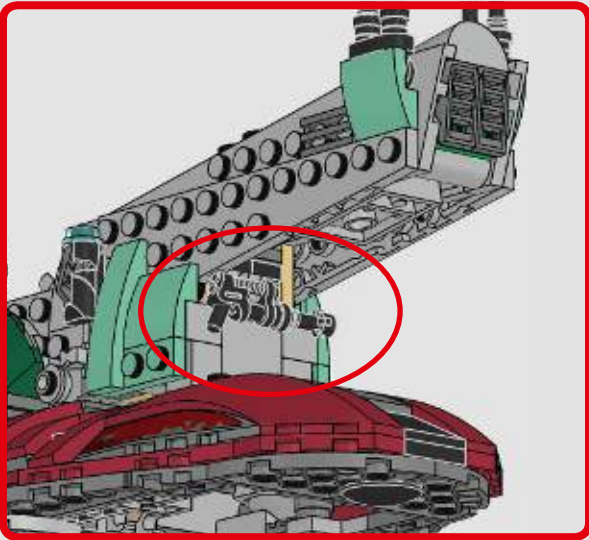
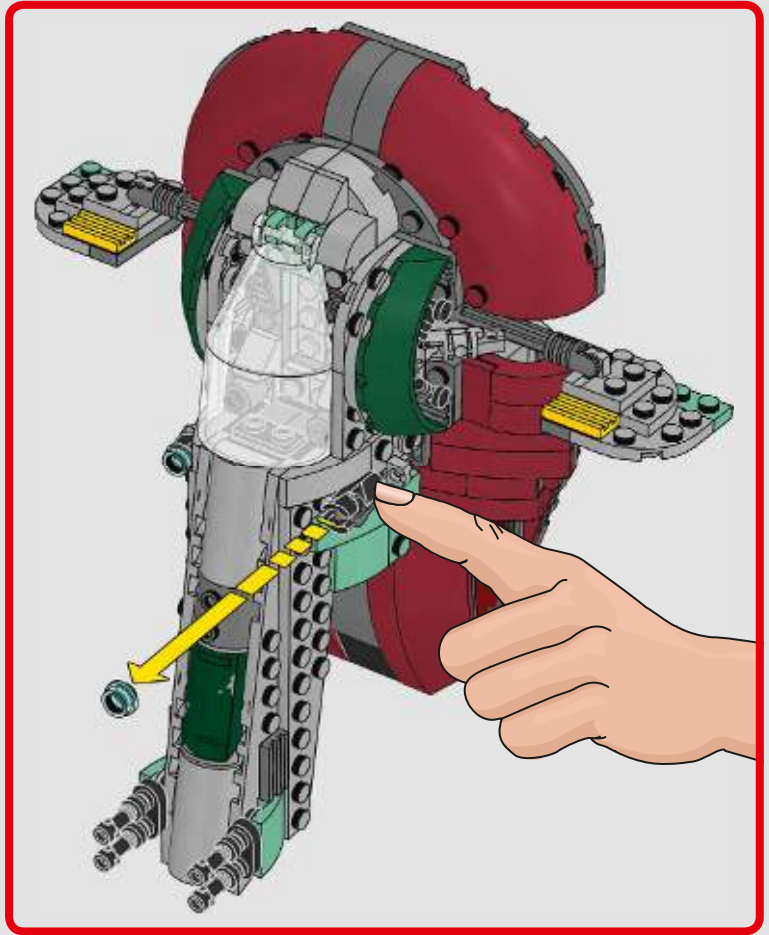
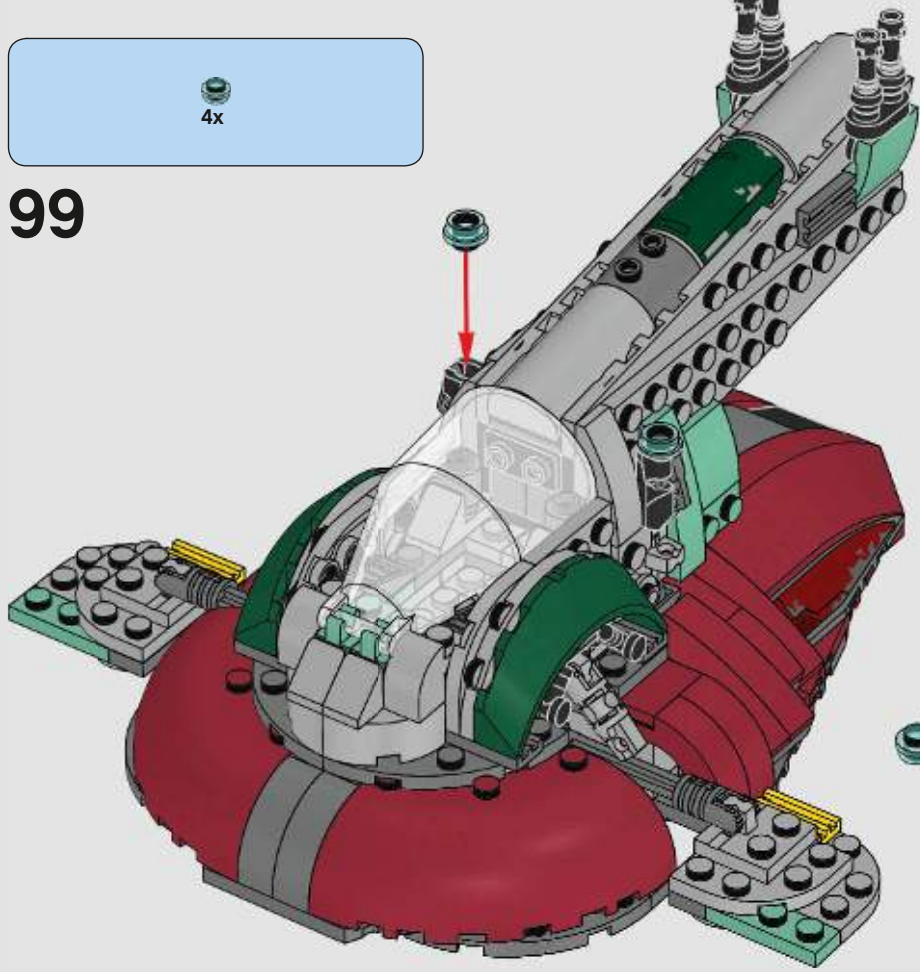

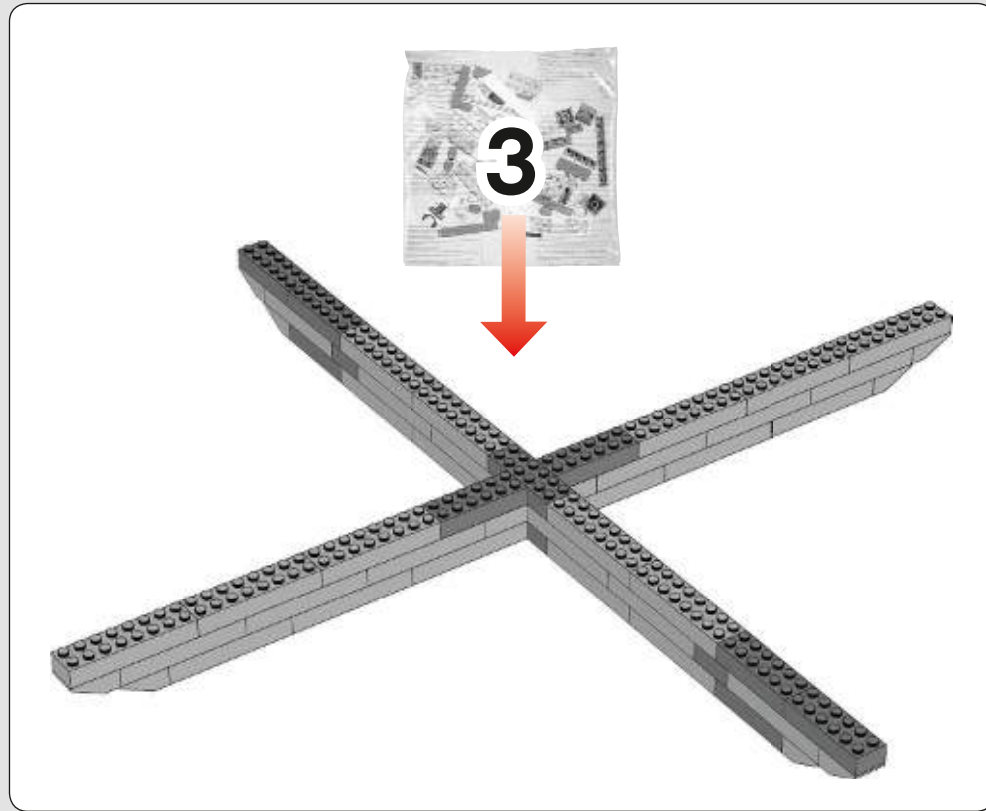

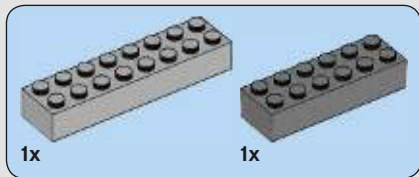
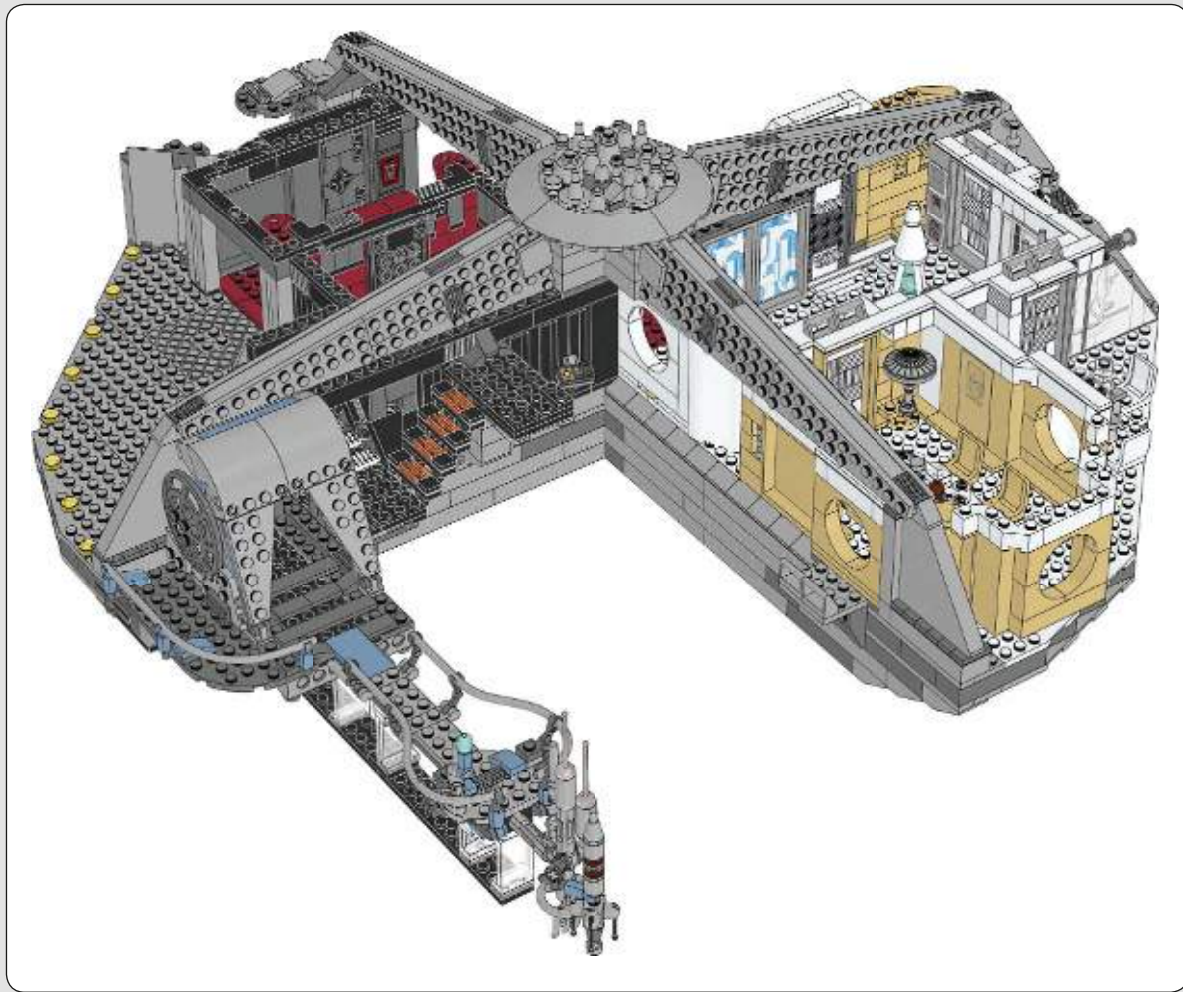

1

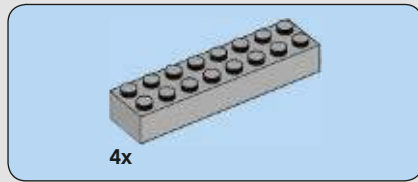
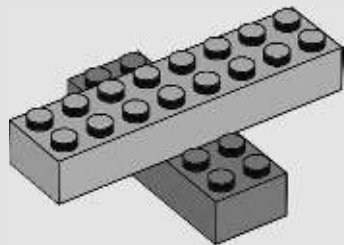

2

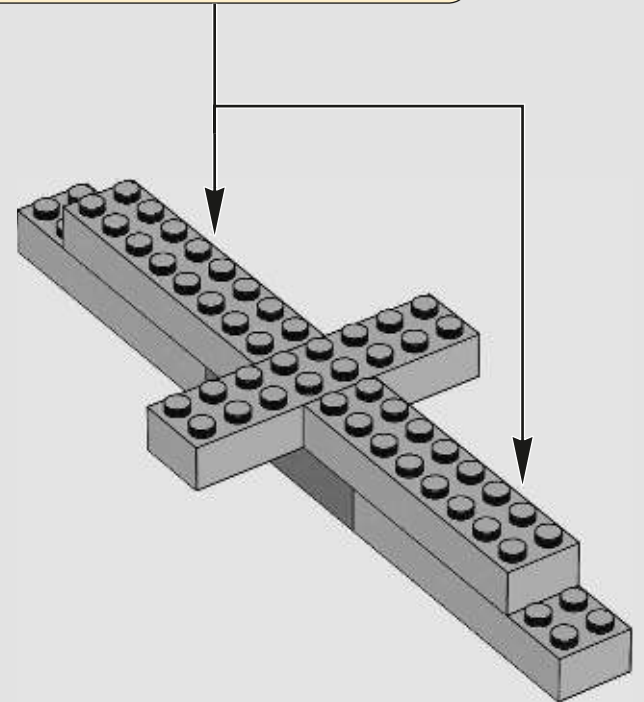
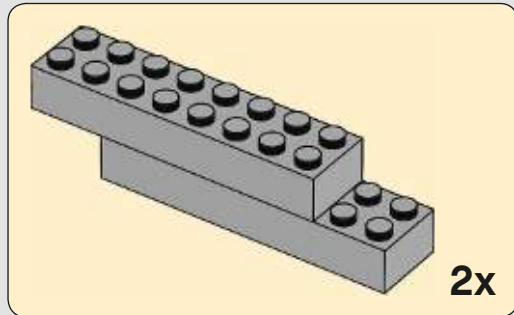

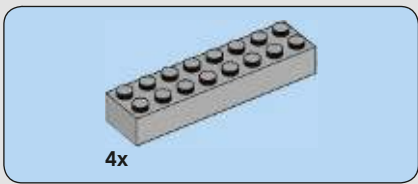

3

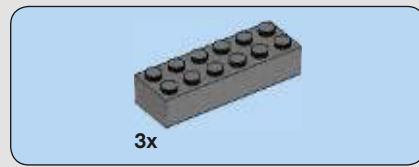
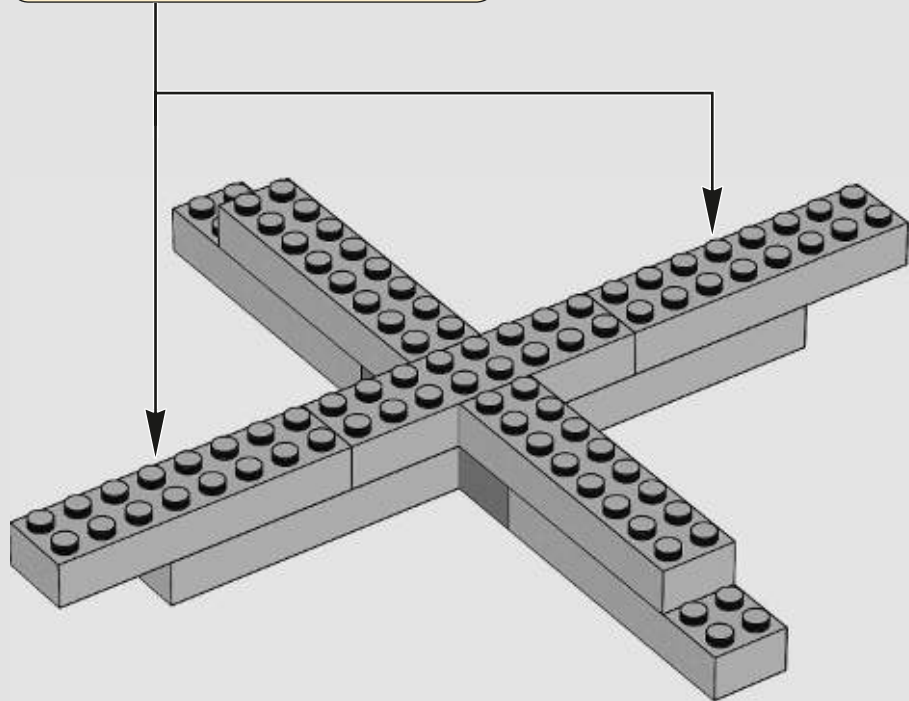
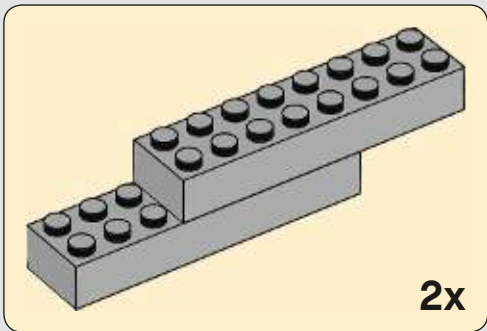

4

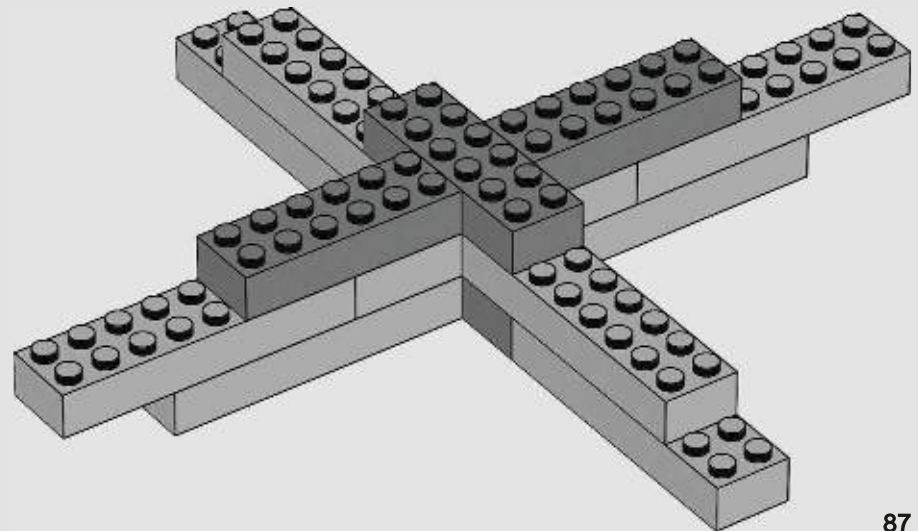

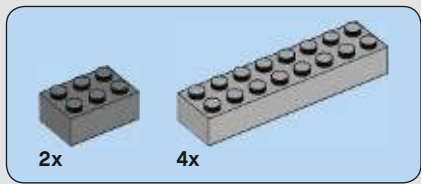

5

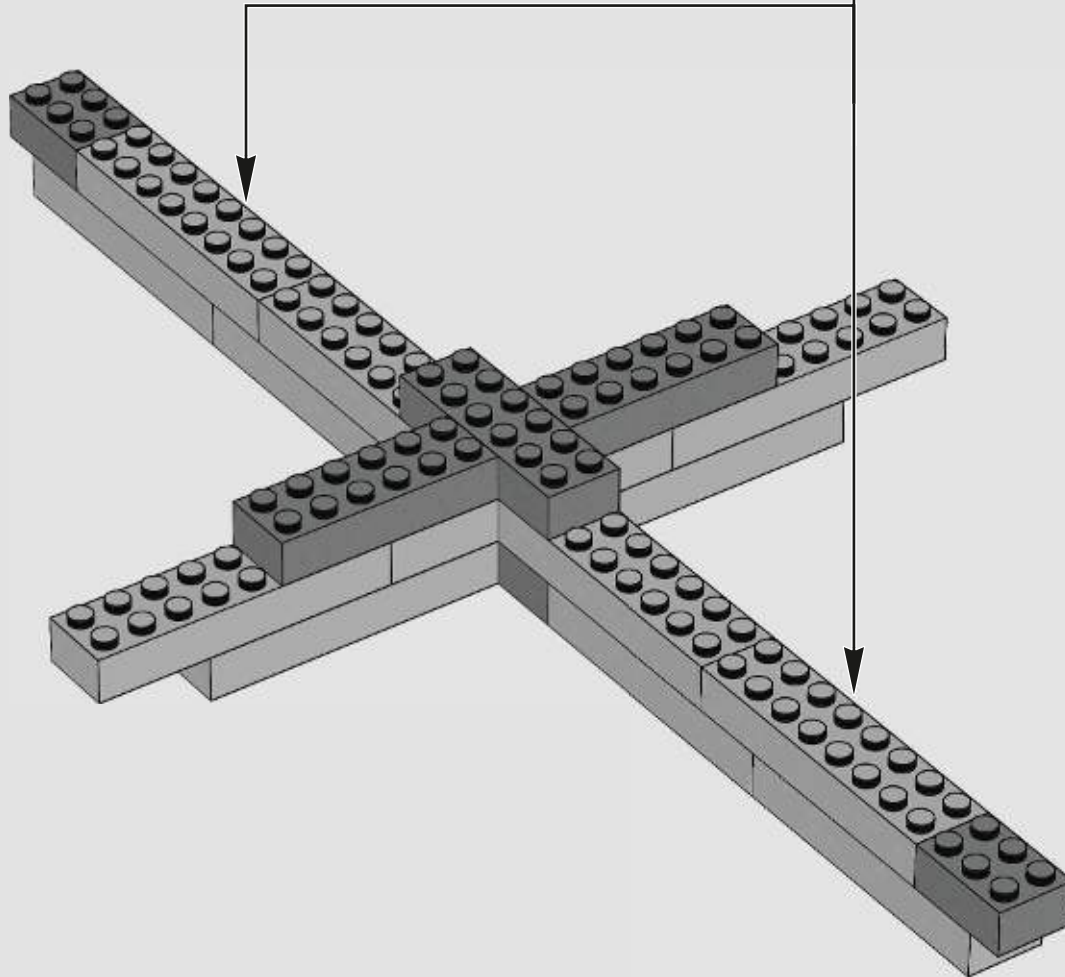
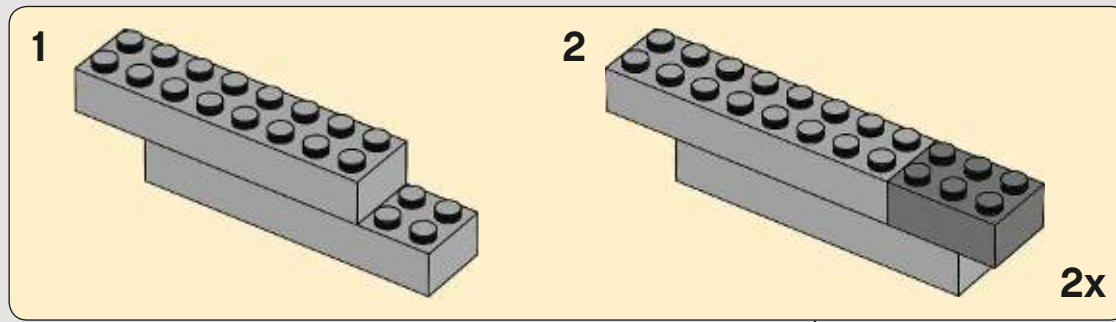

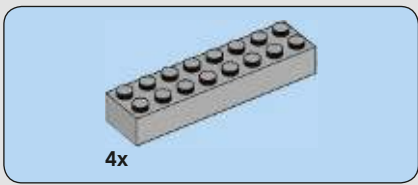

6

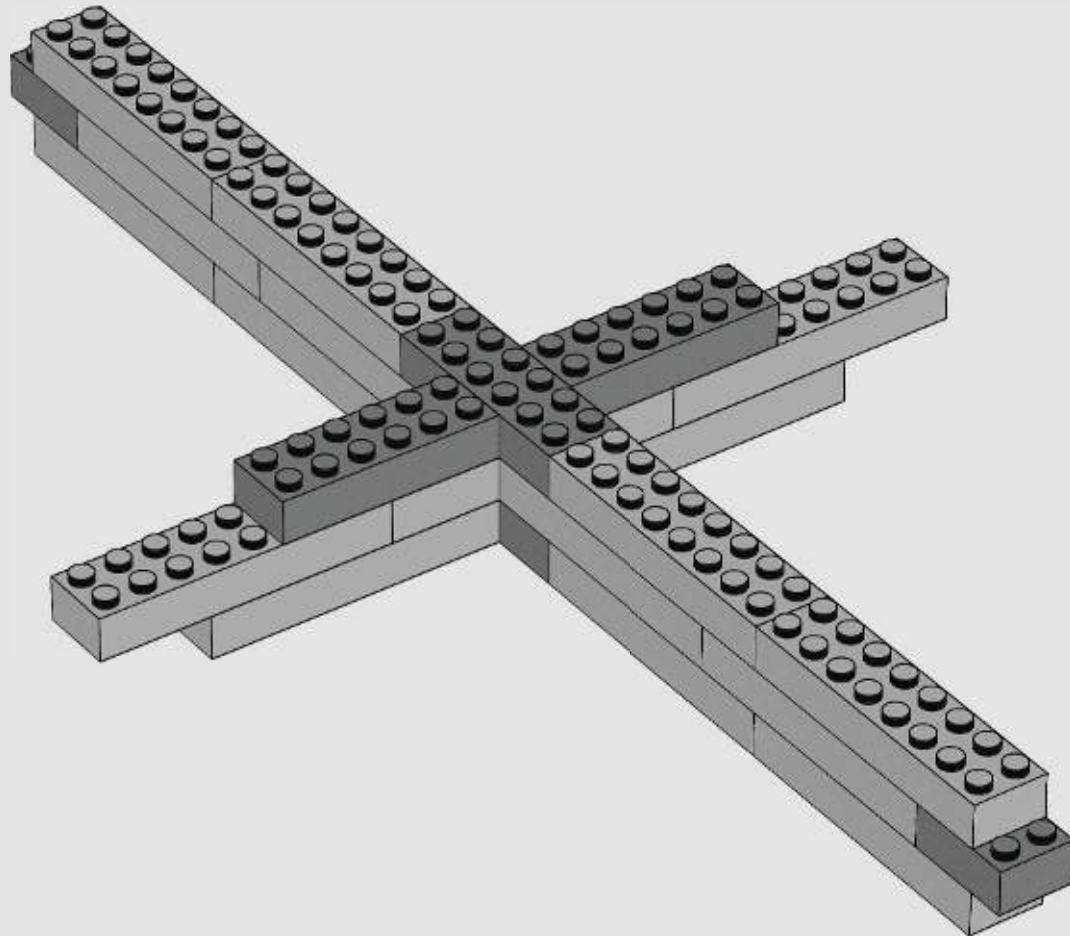

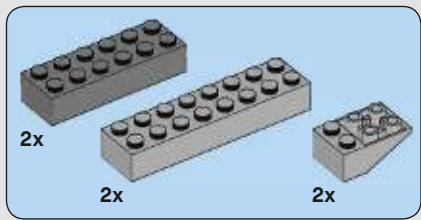

7

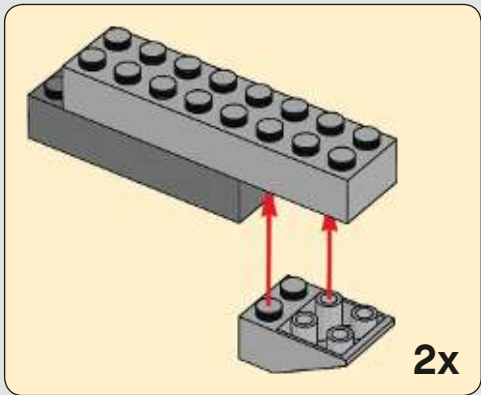
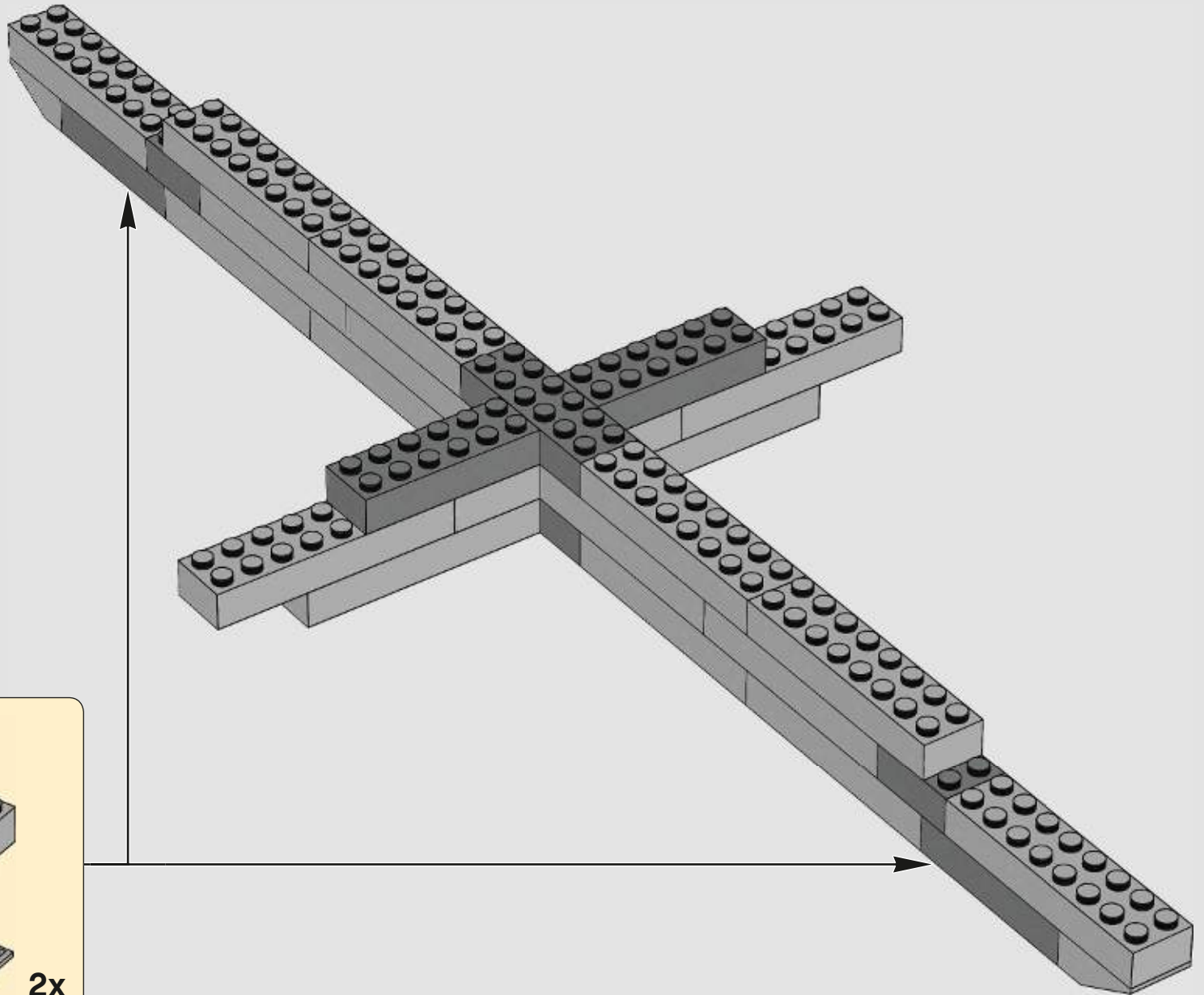

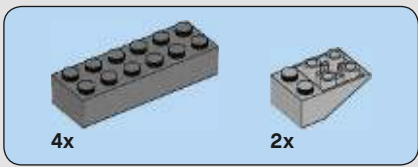

8

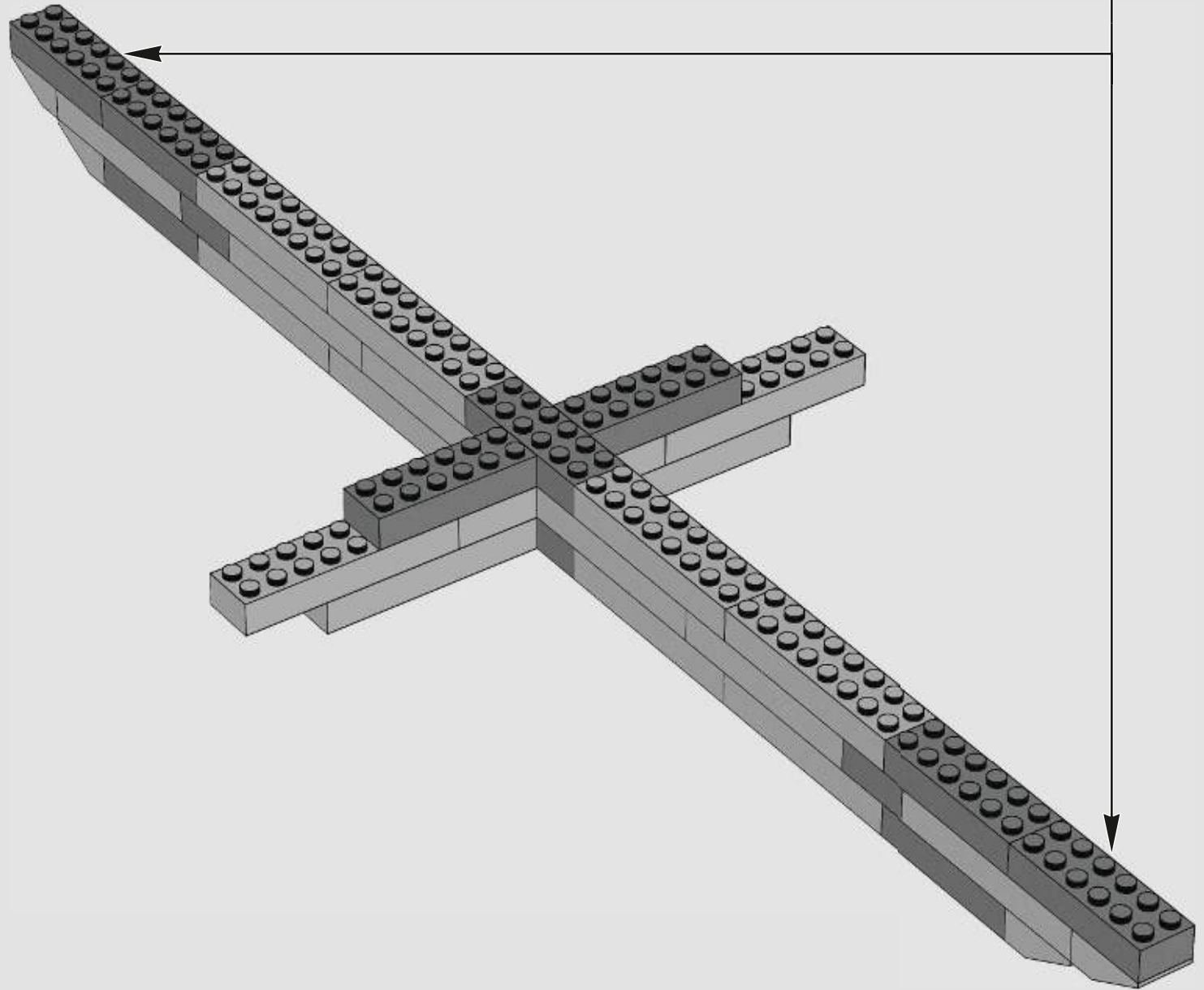
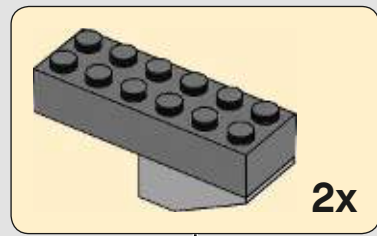

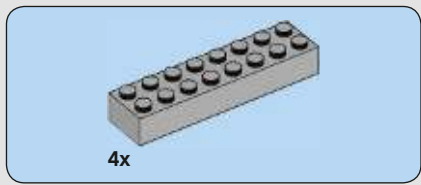

9

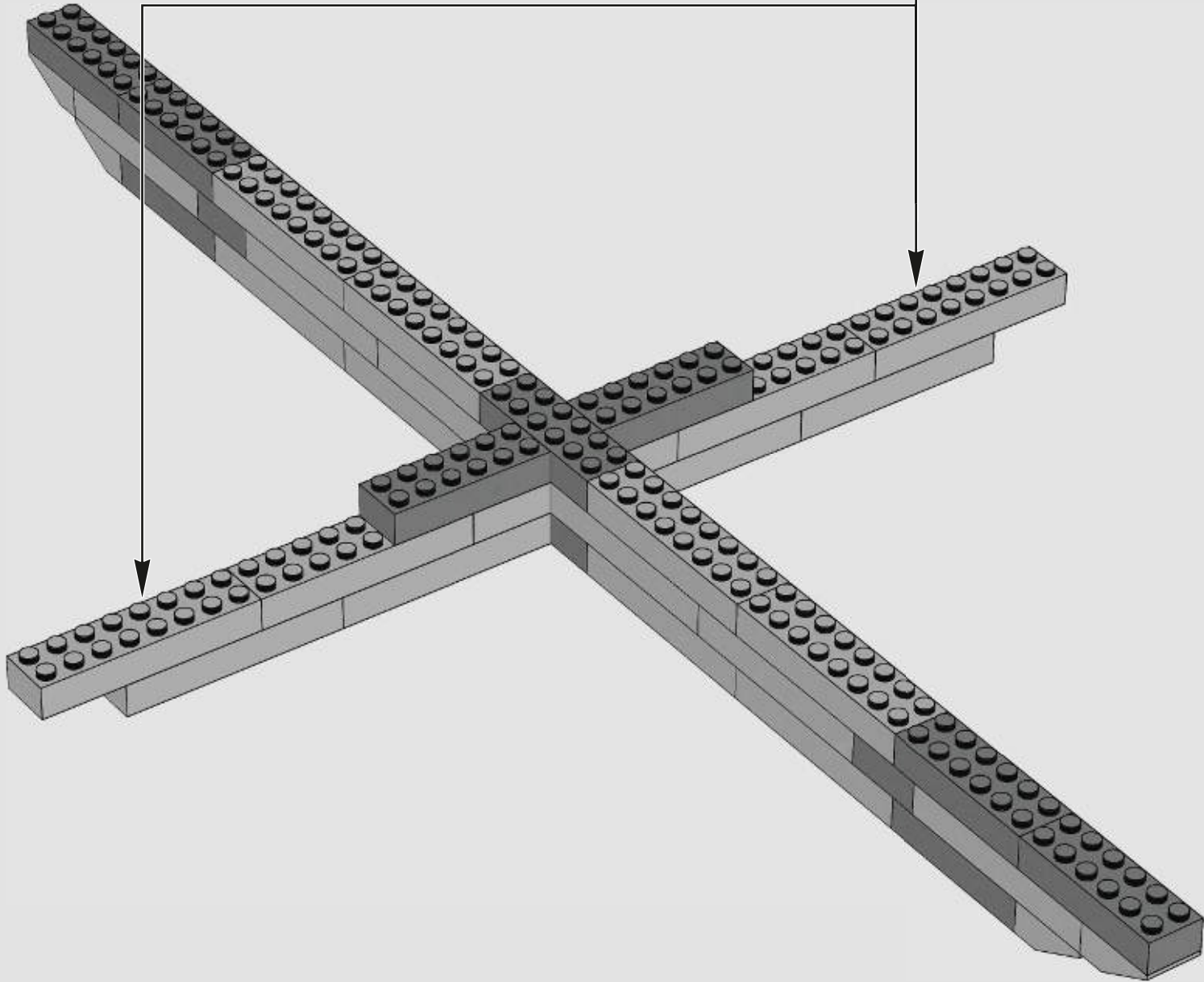
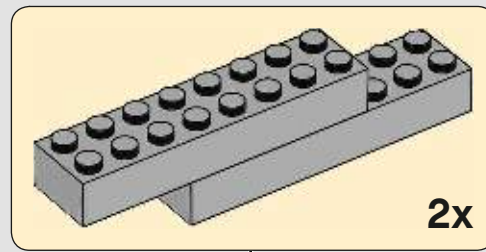

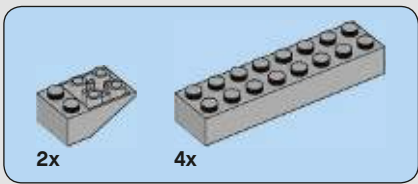

10

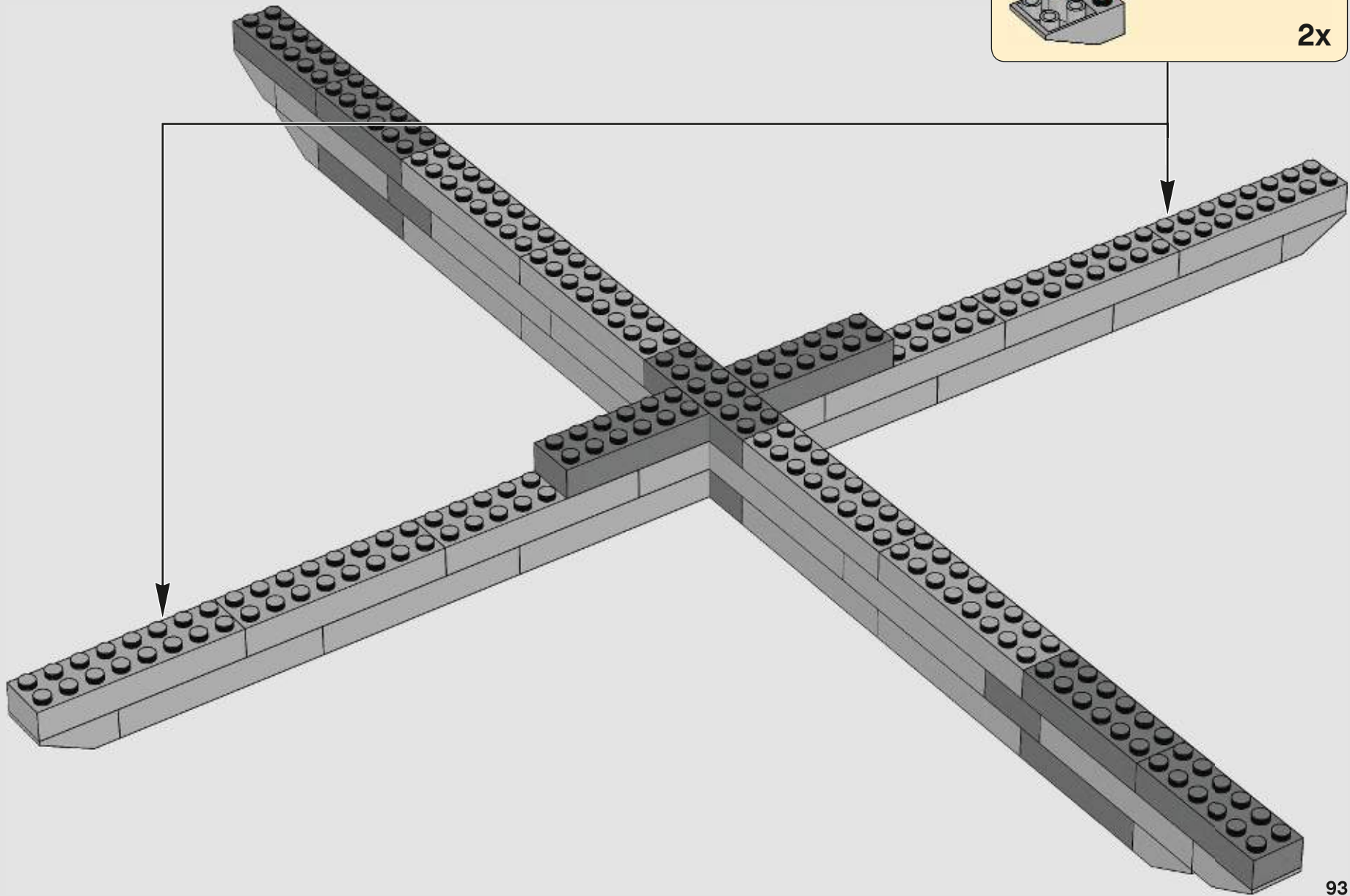
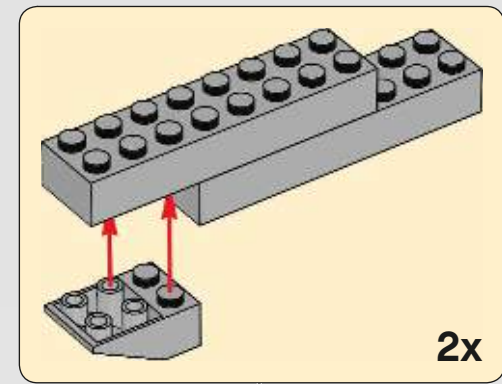

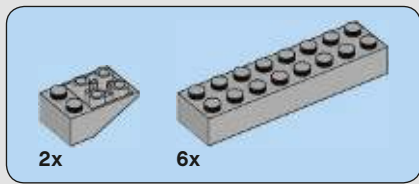

11

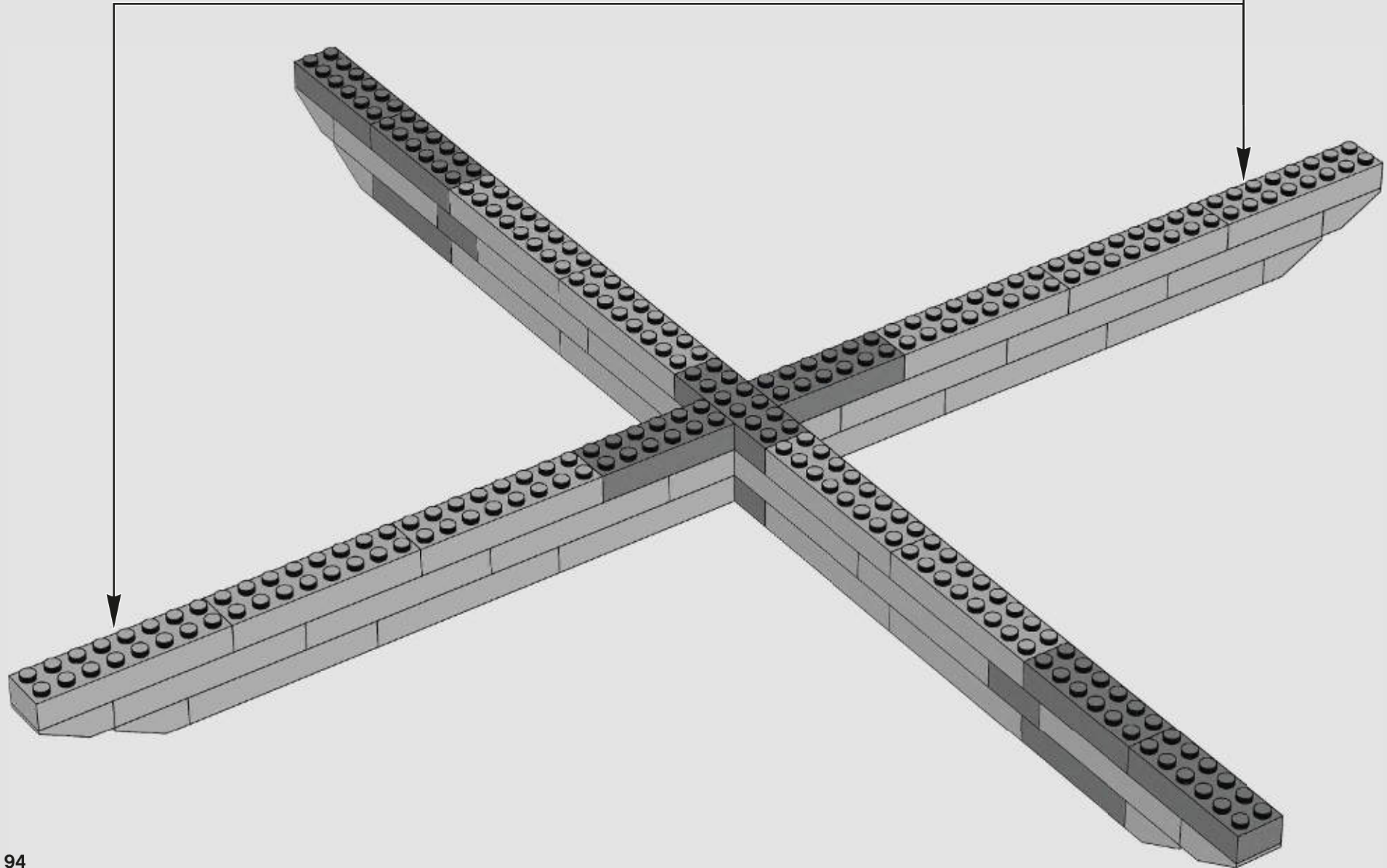
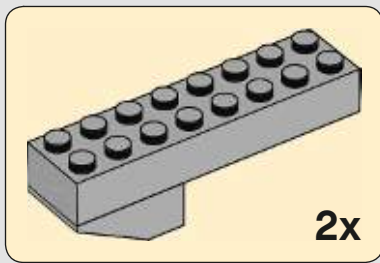

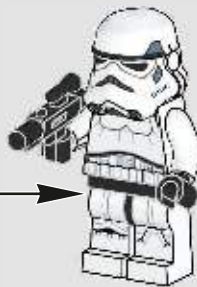
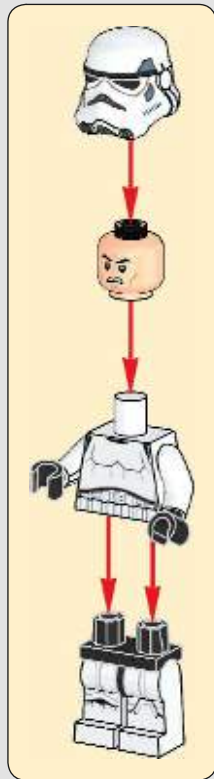
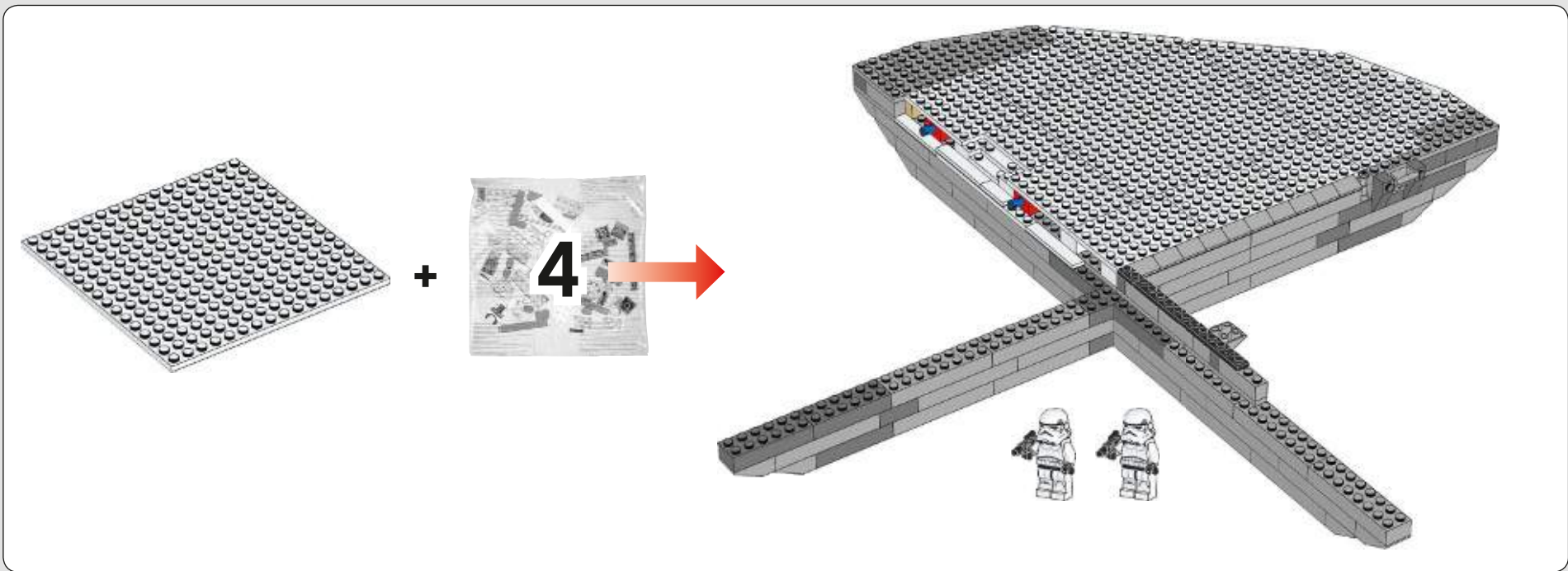

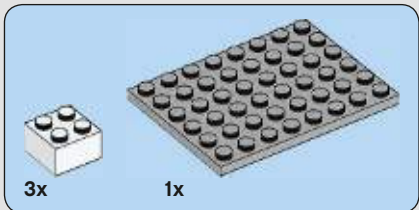
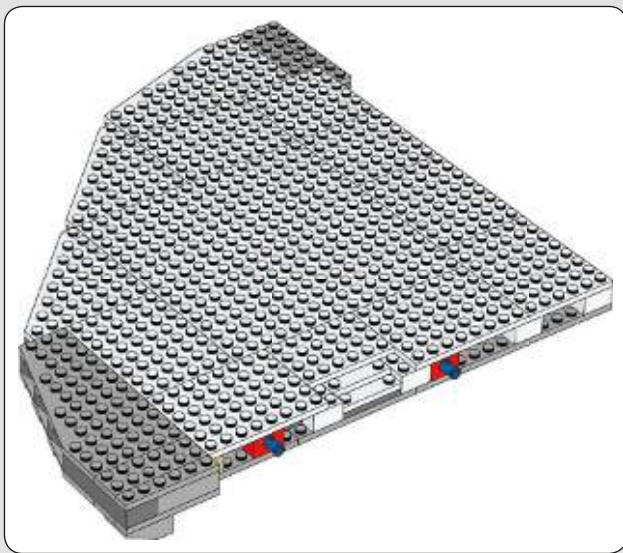

12

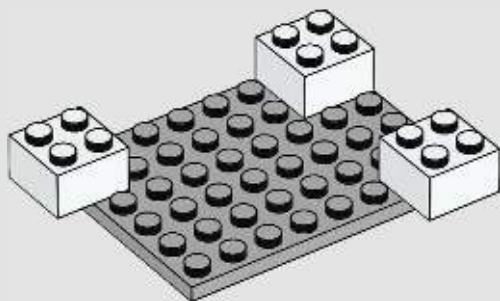

13

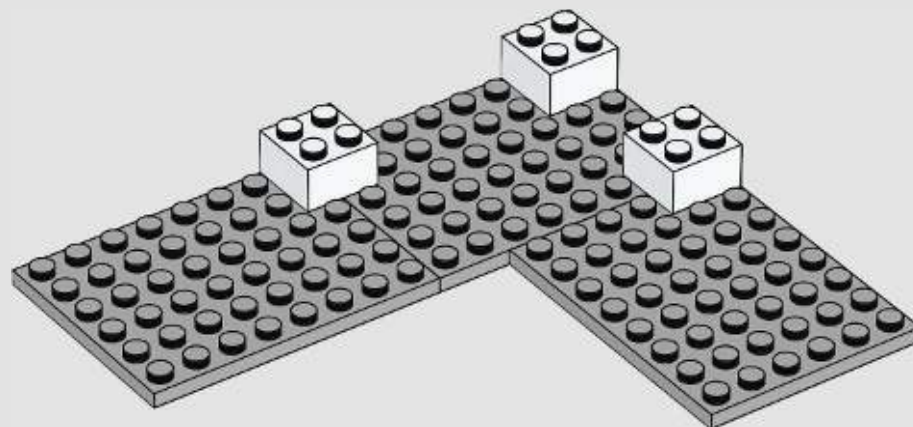



14

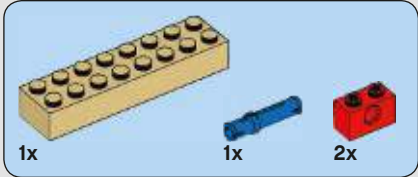
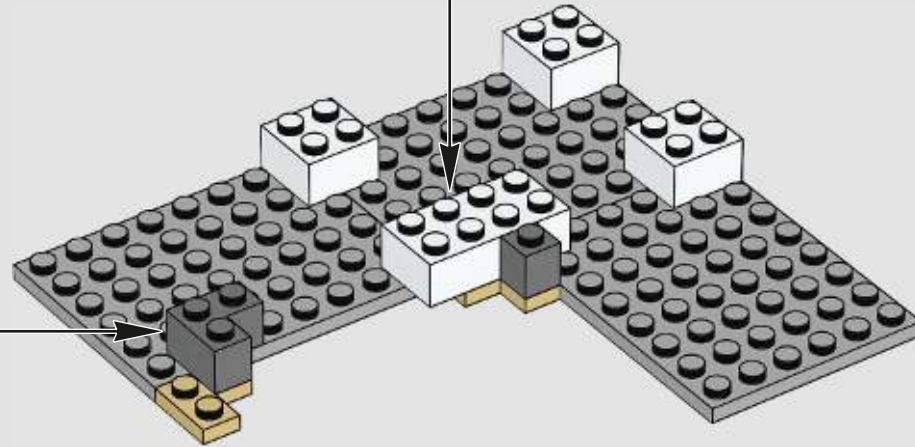
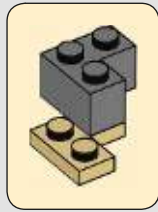
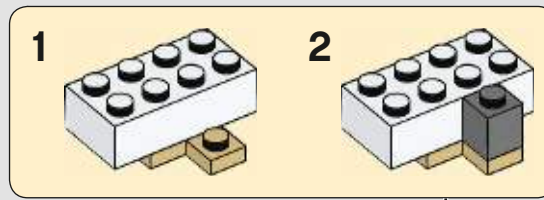

15

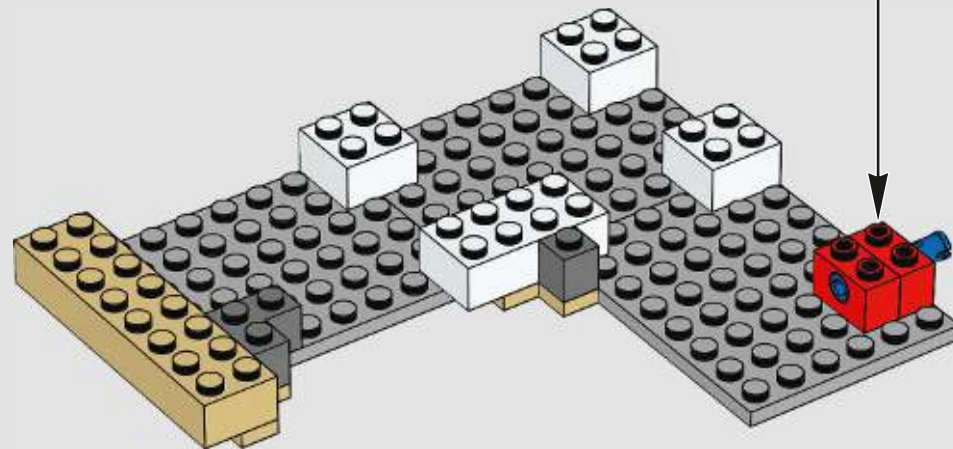
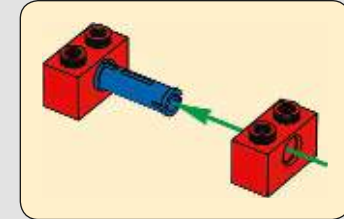

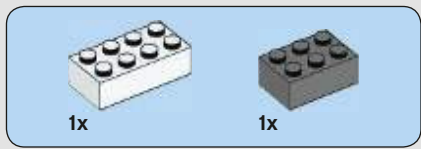

16

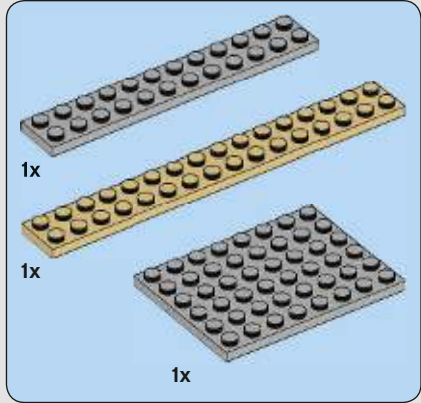
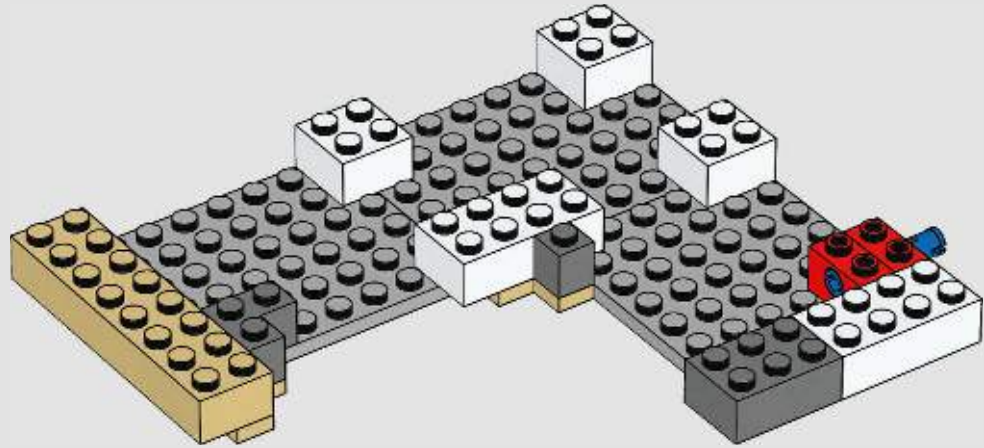

17

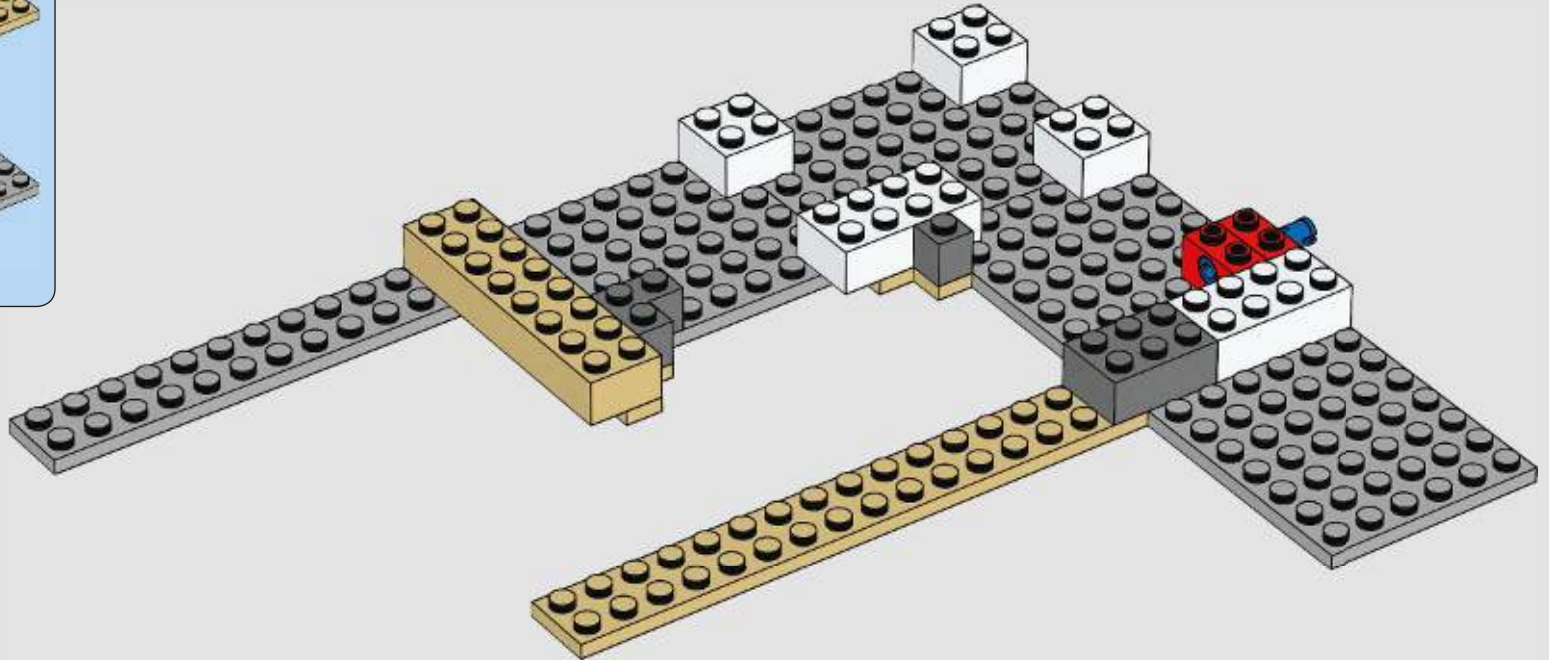

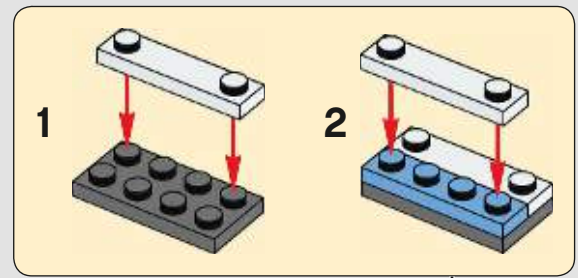
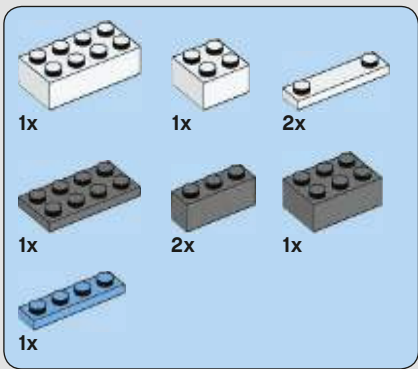

18

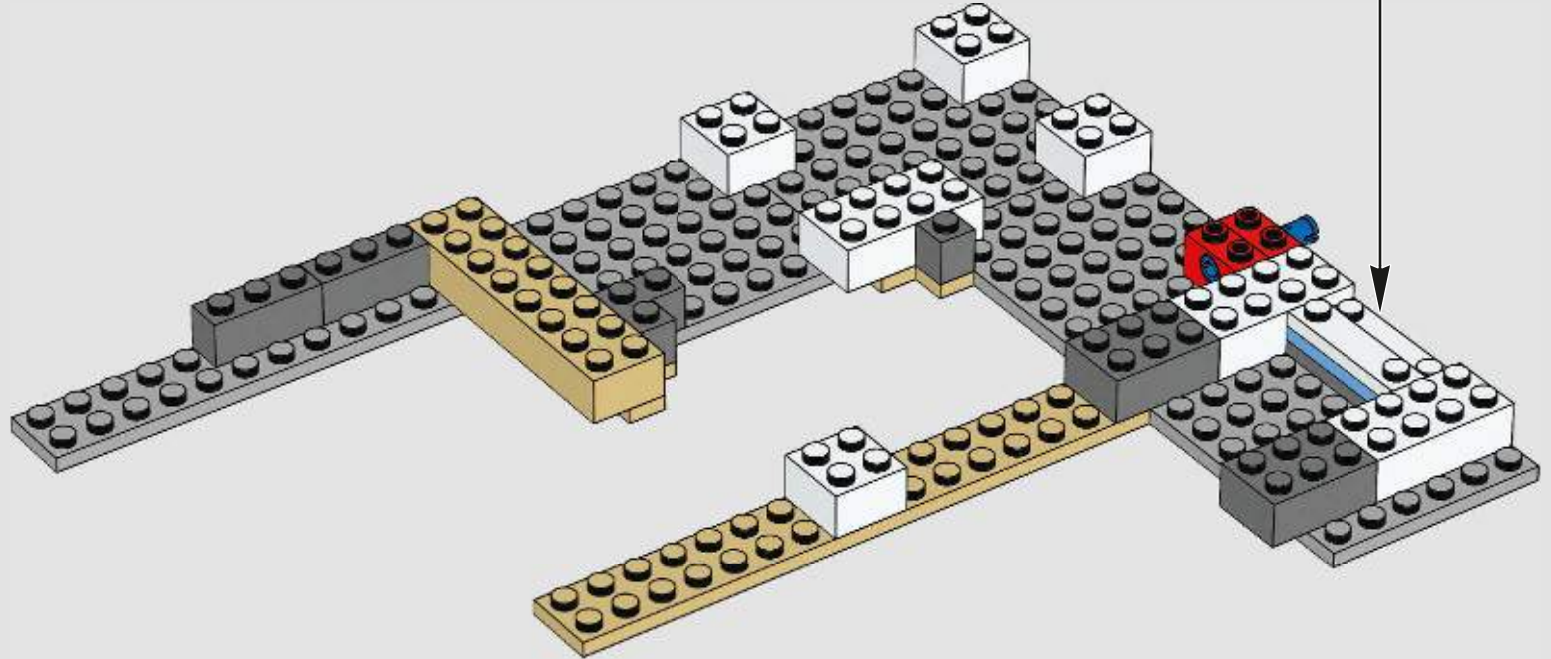

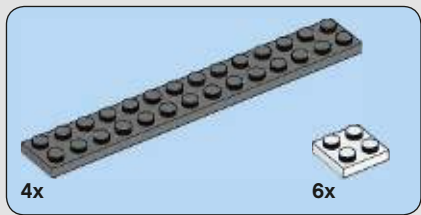

19

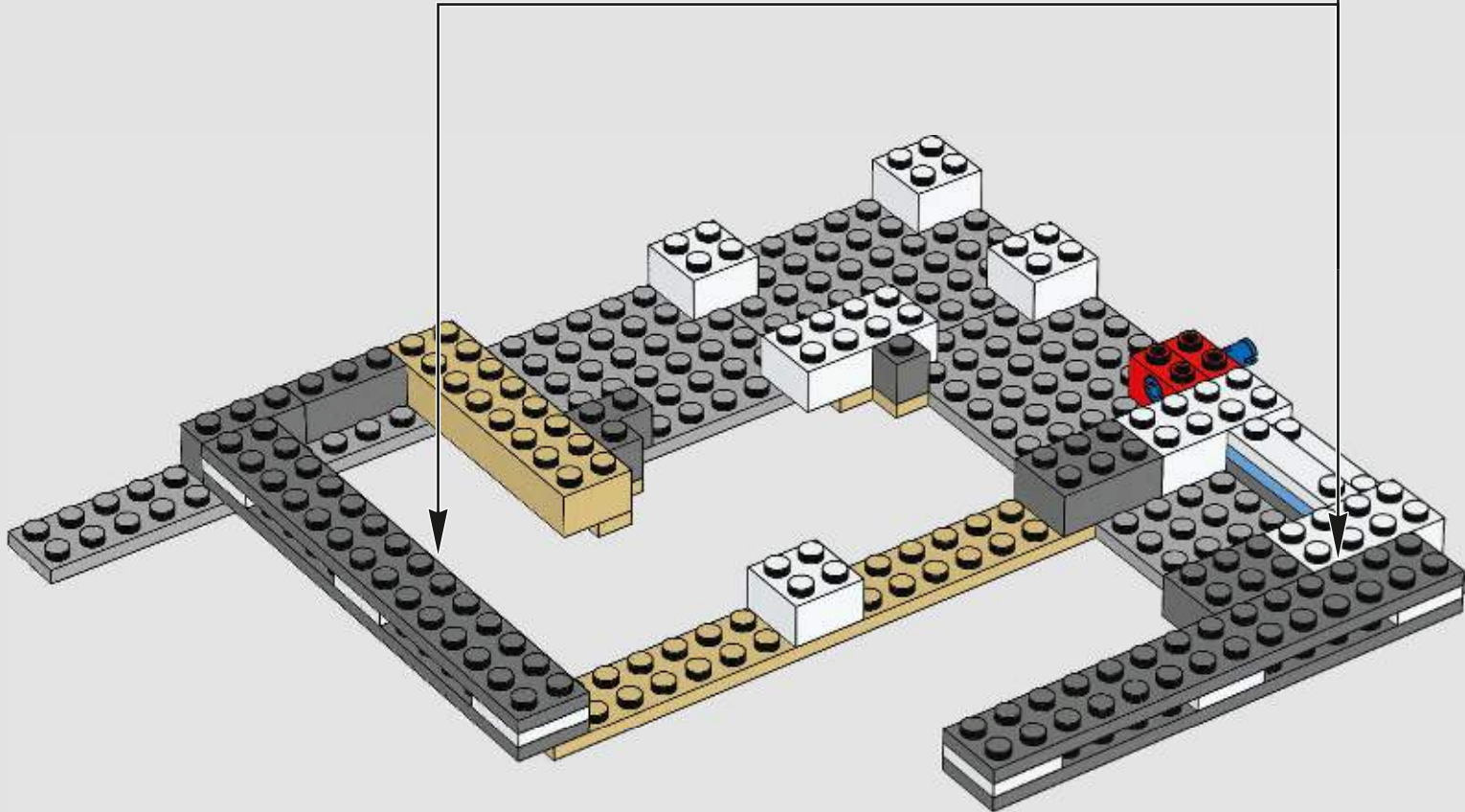
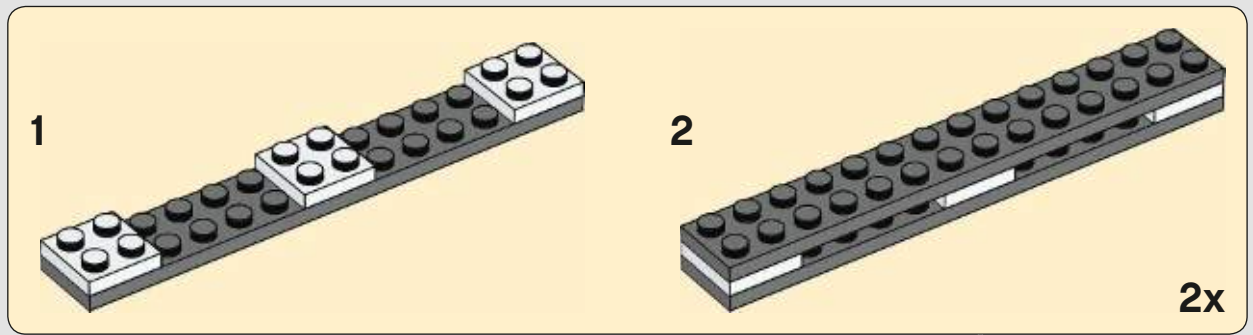

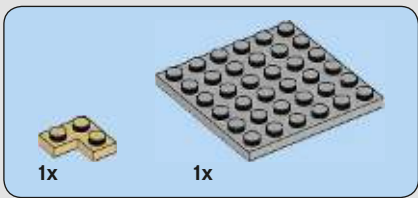

20

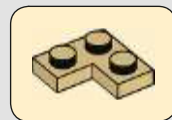
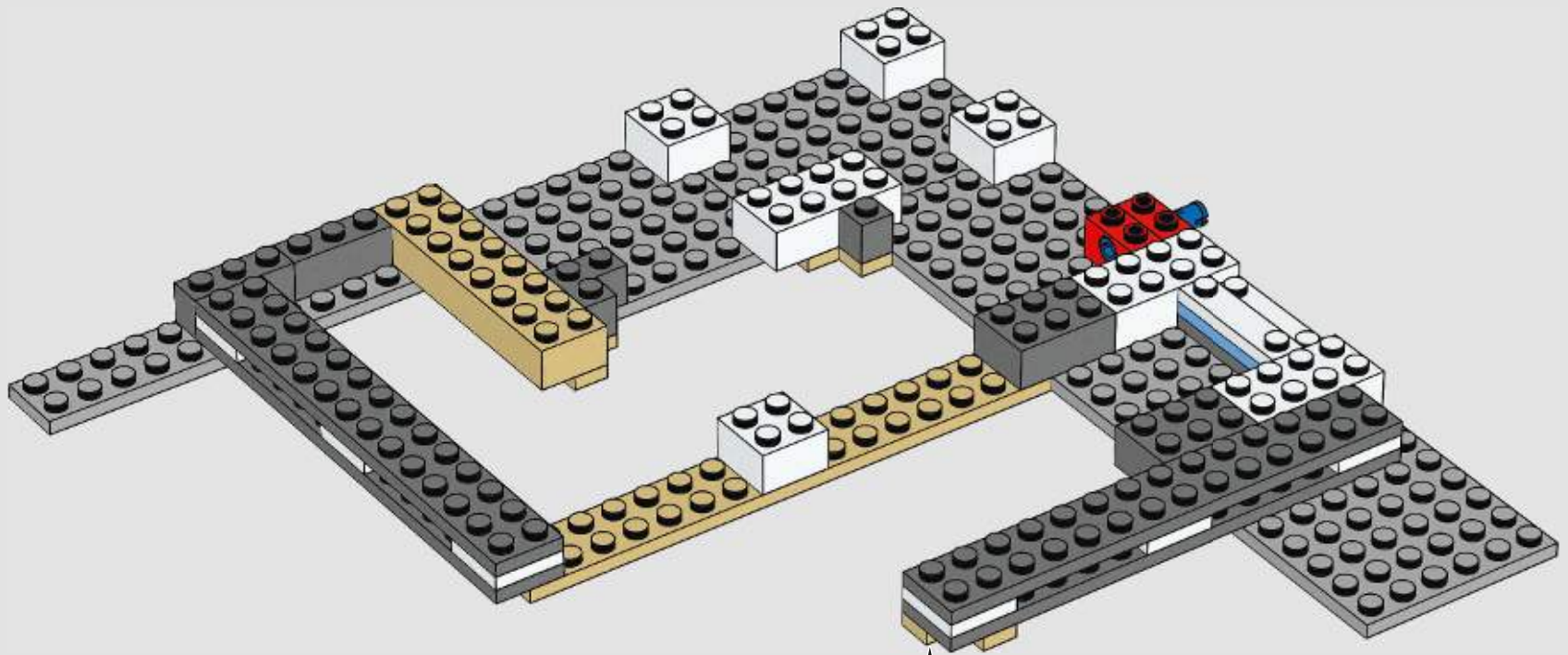

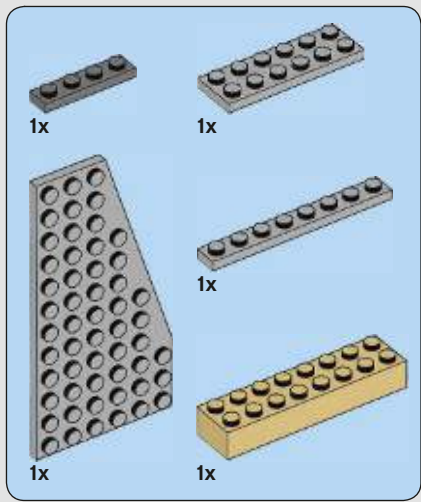

21

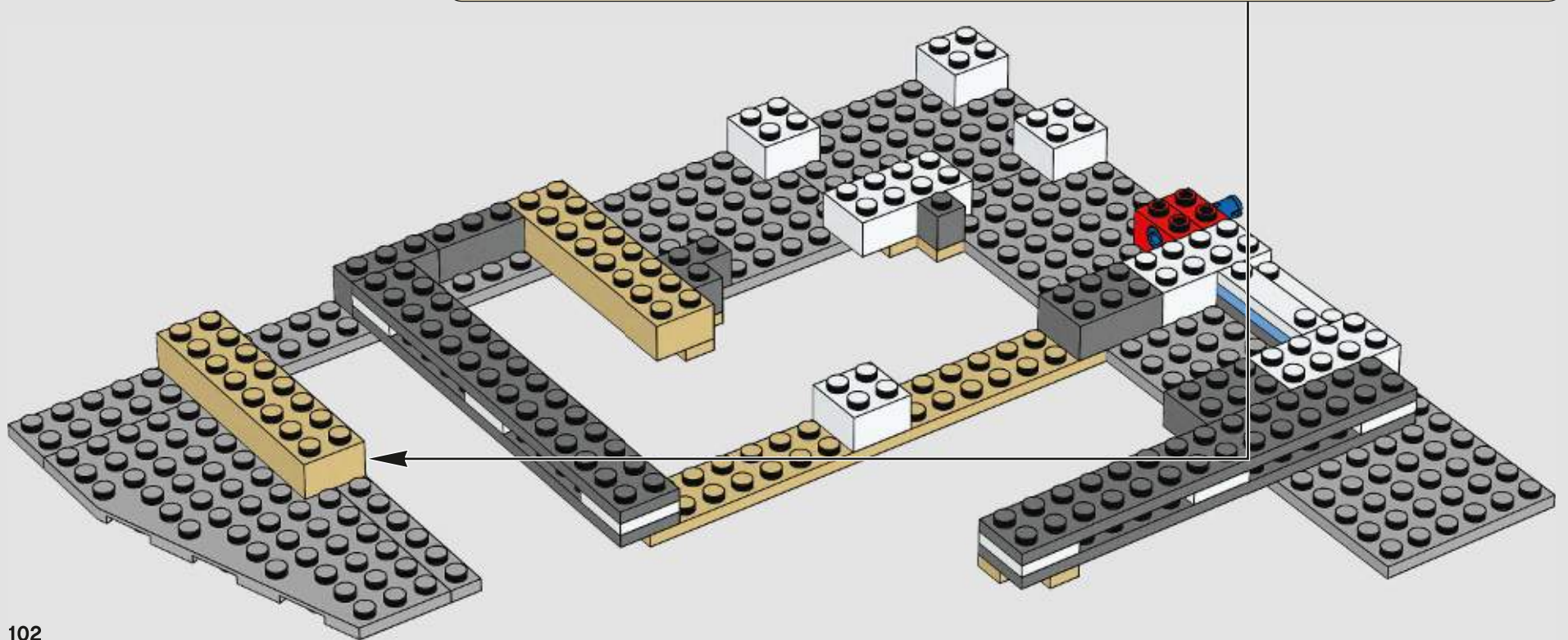
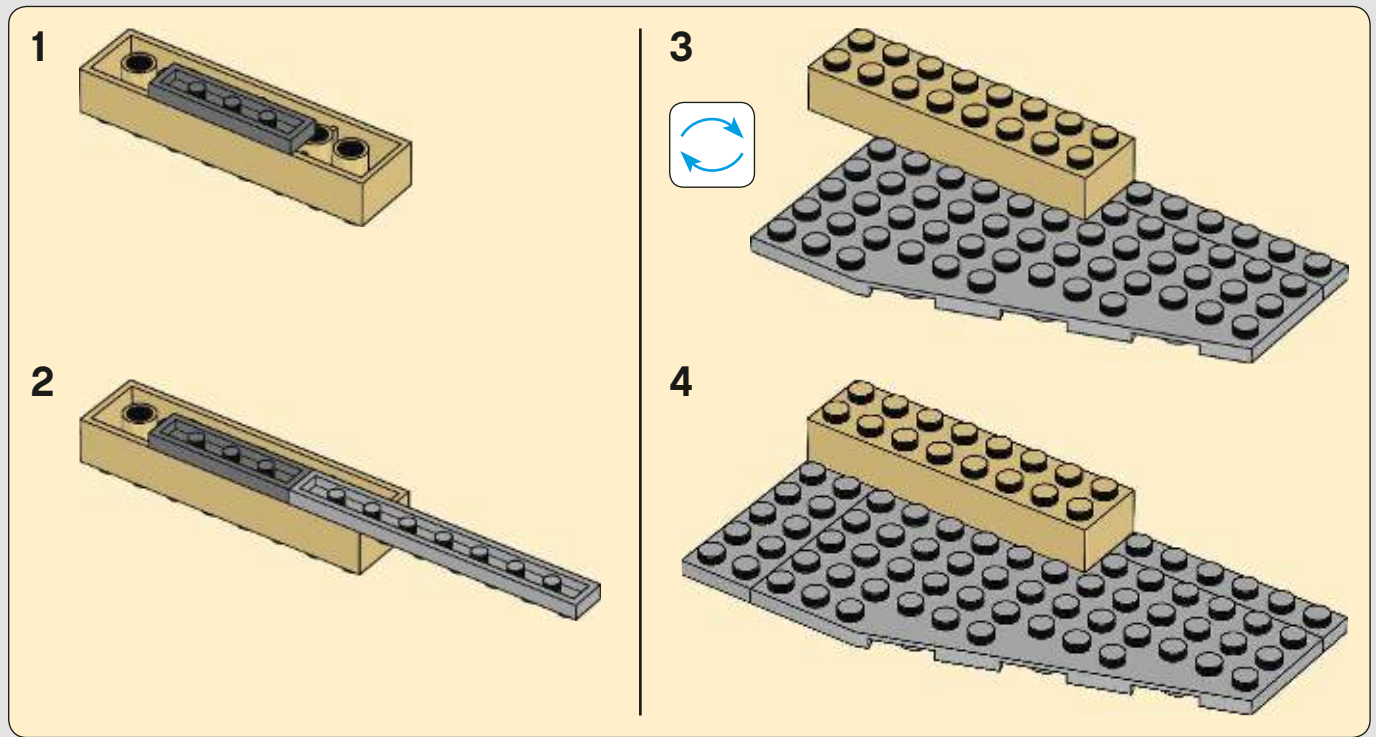

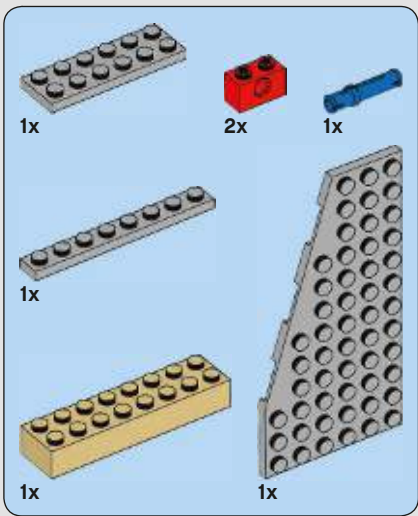

22

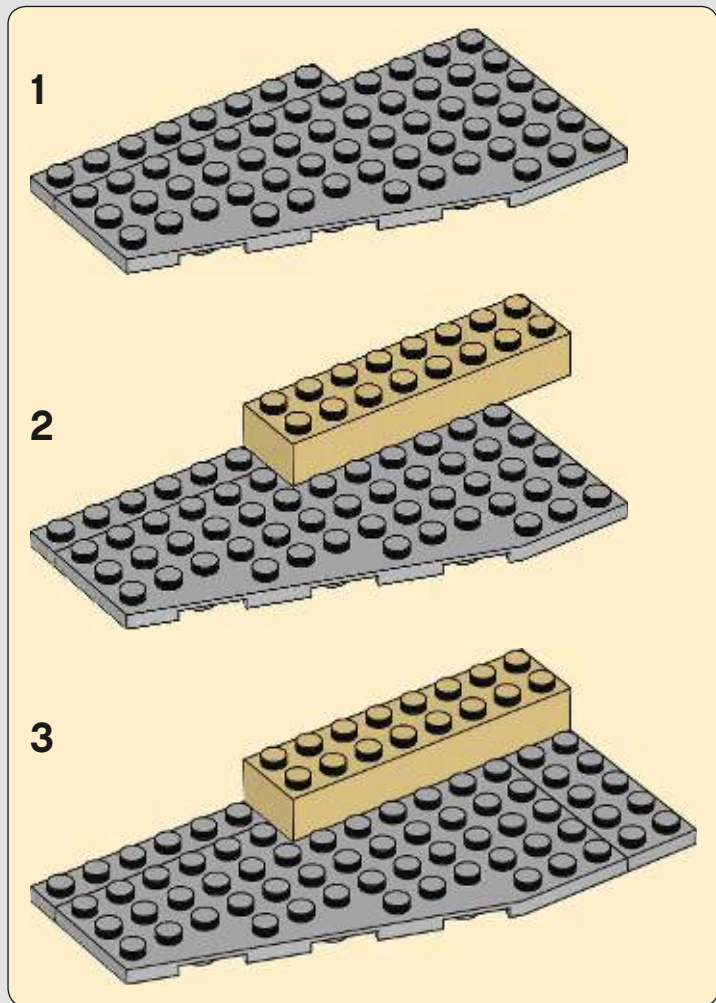
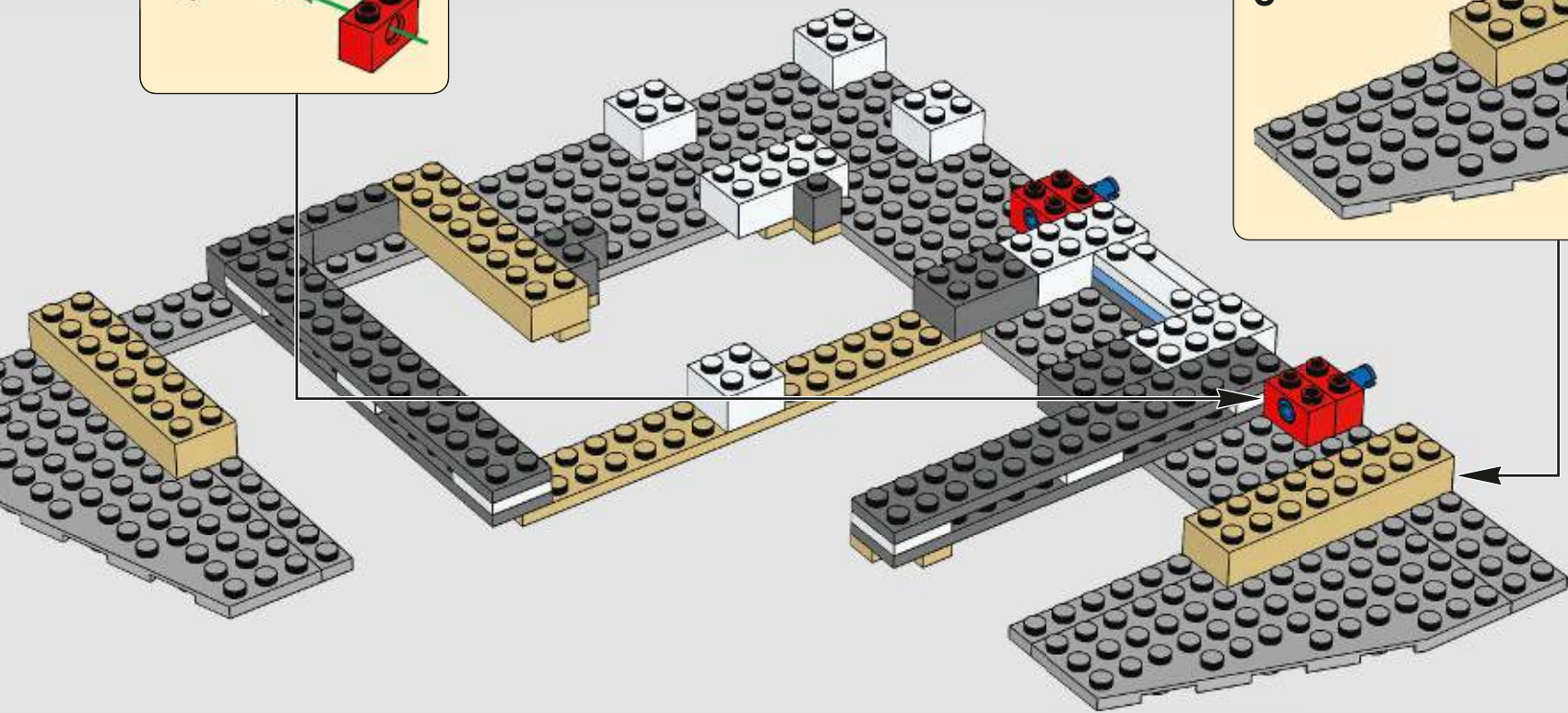
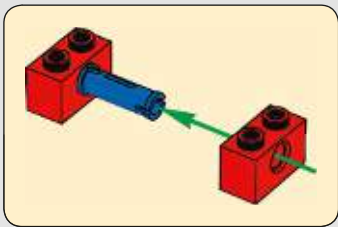

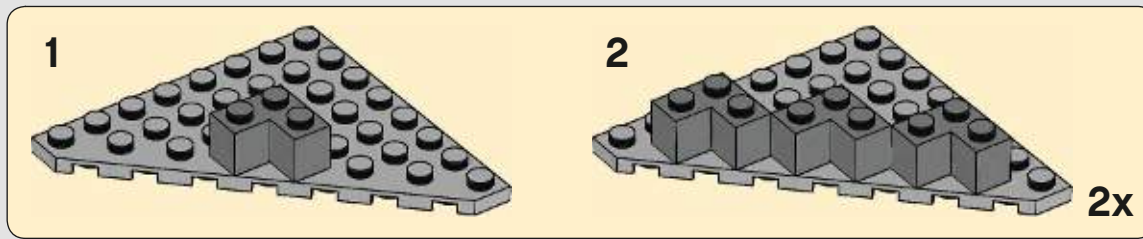
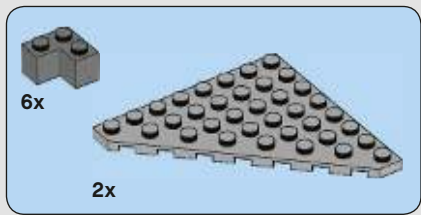

23

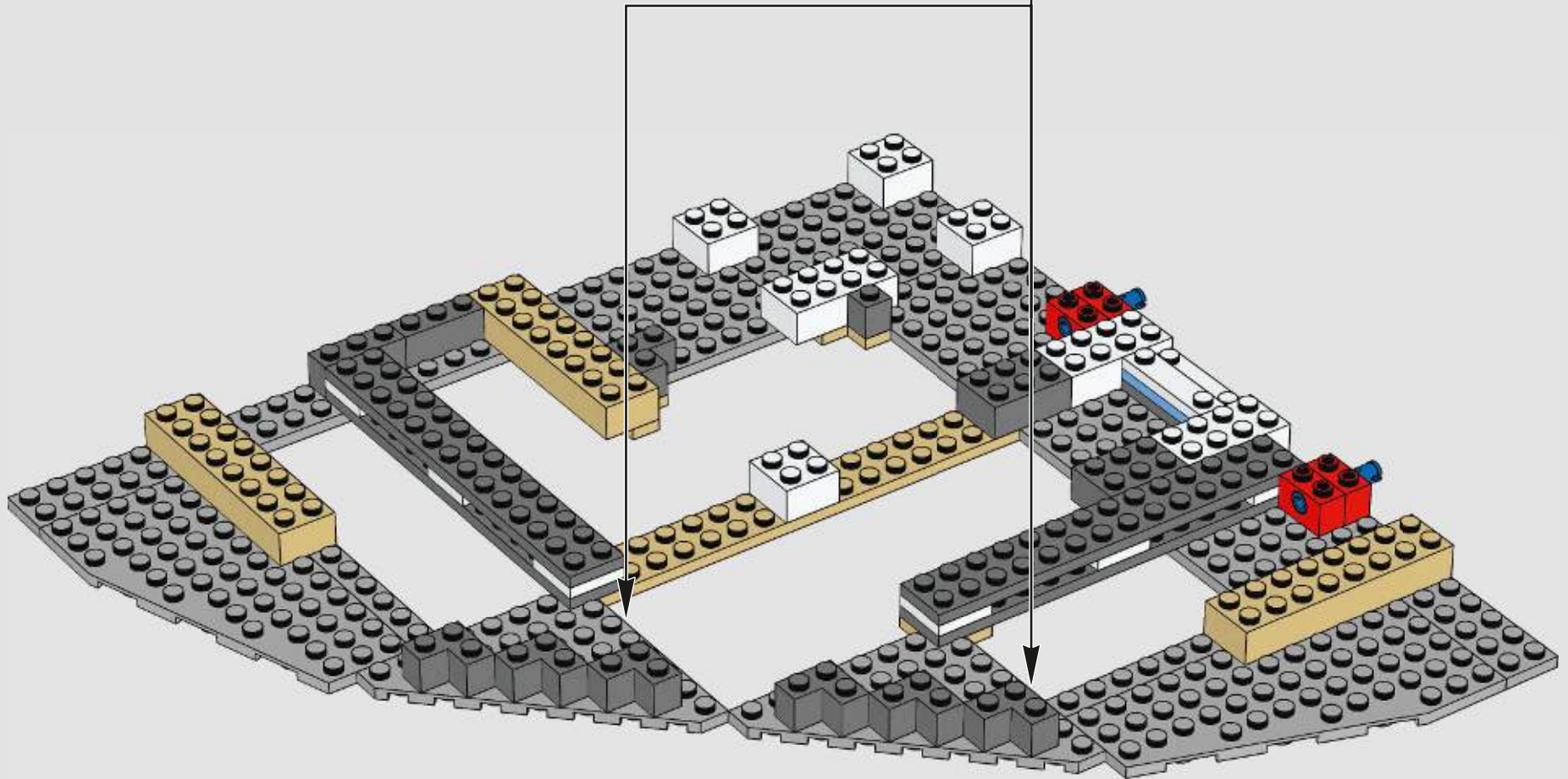

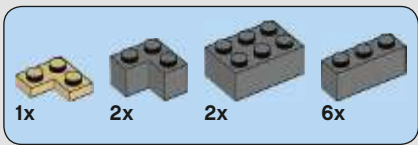

24

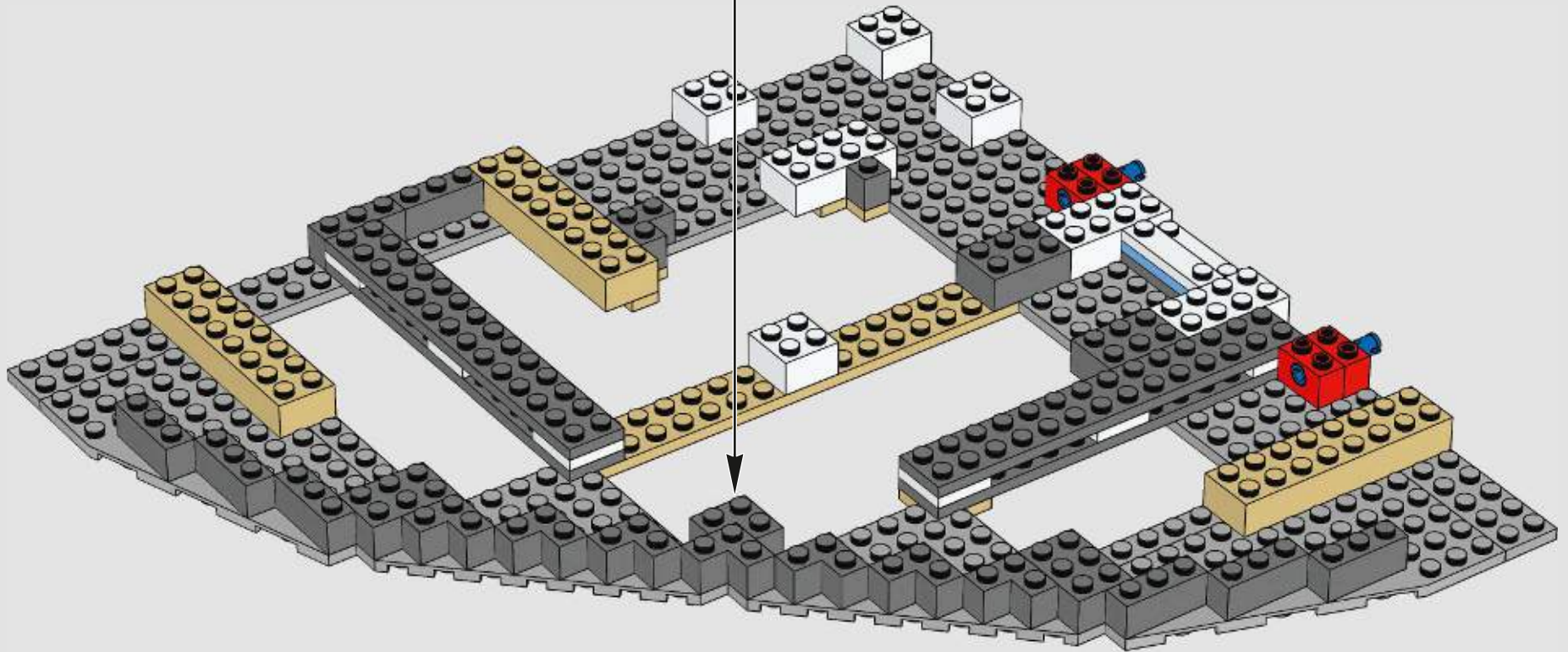
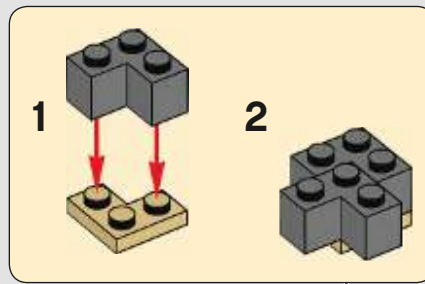

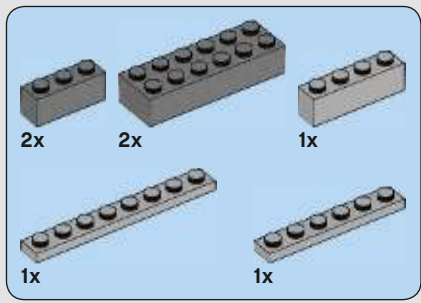

25

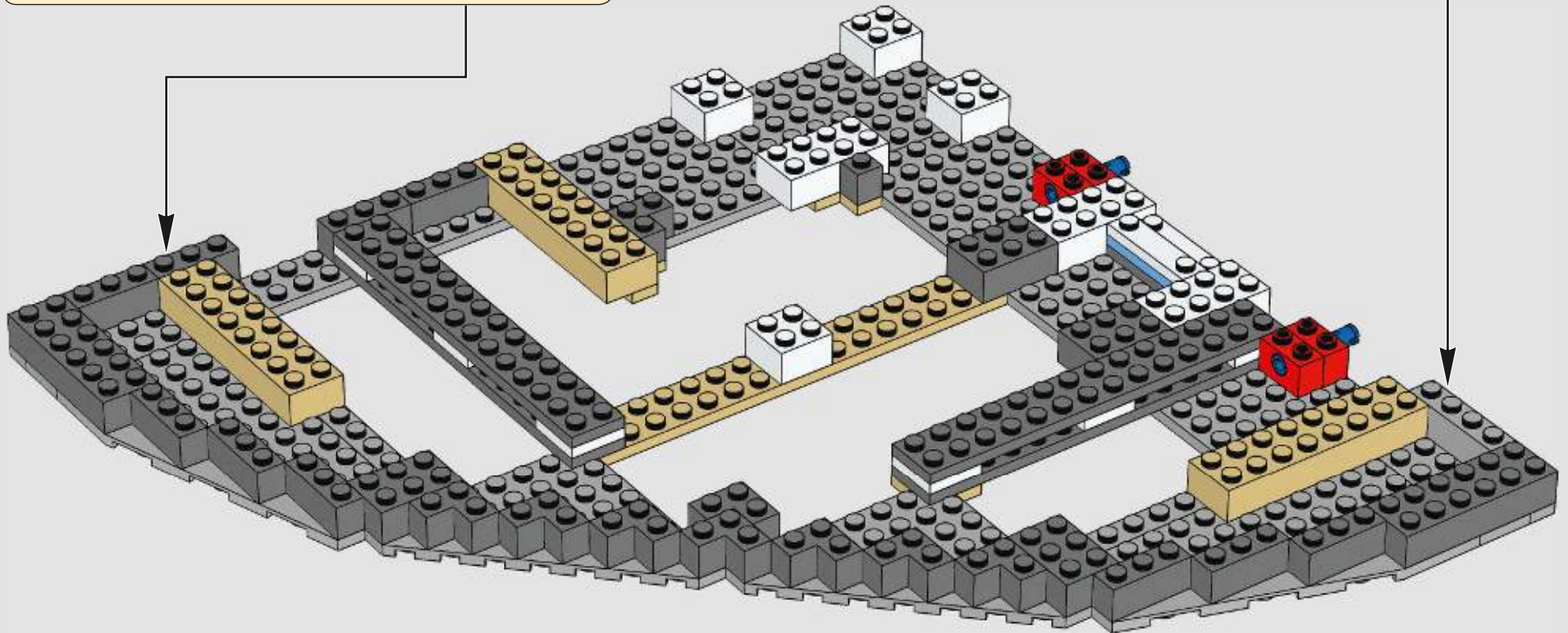
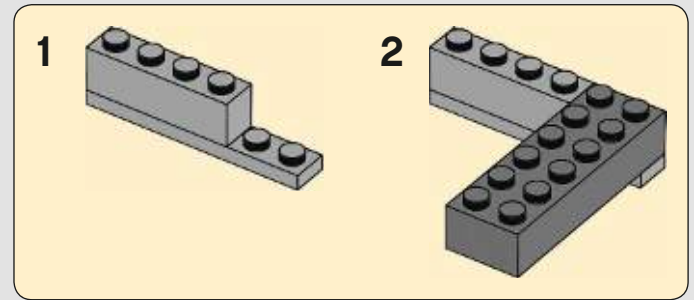
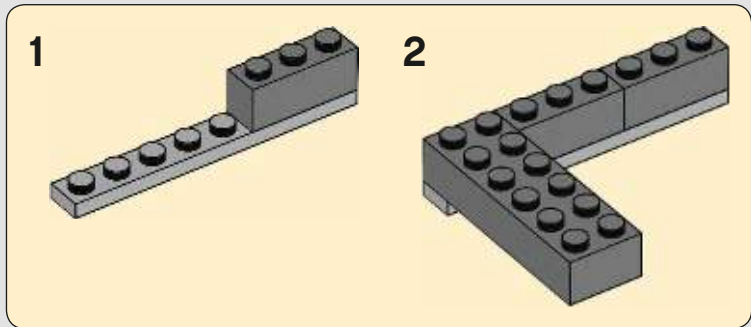

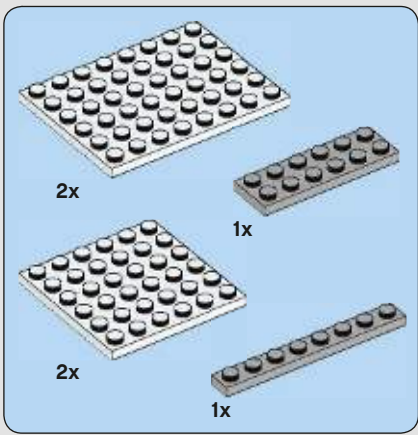

26

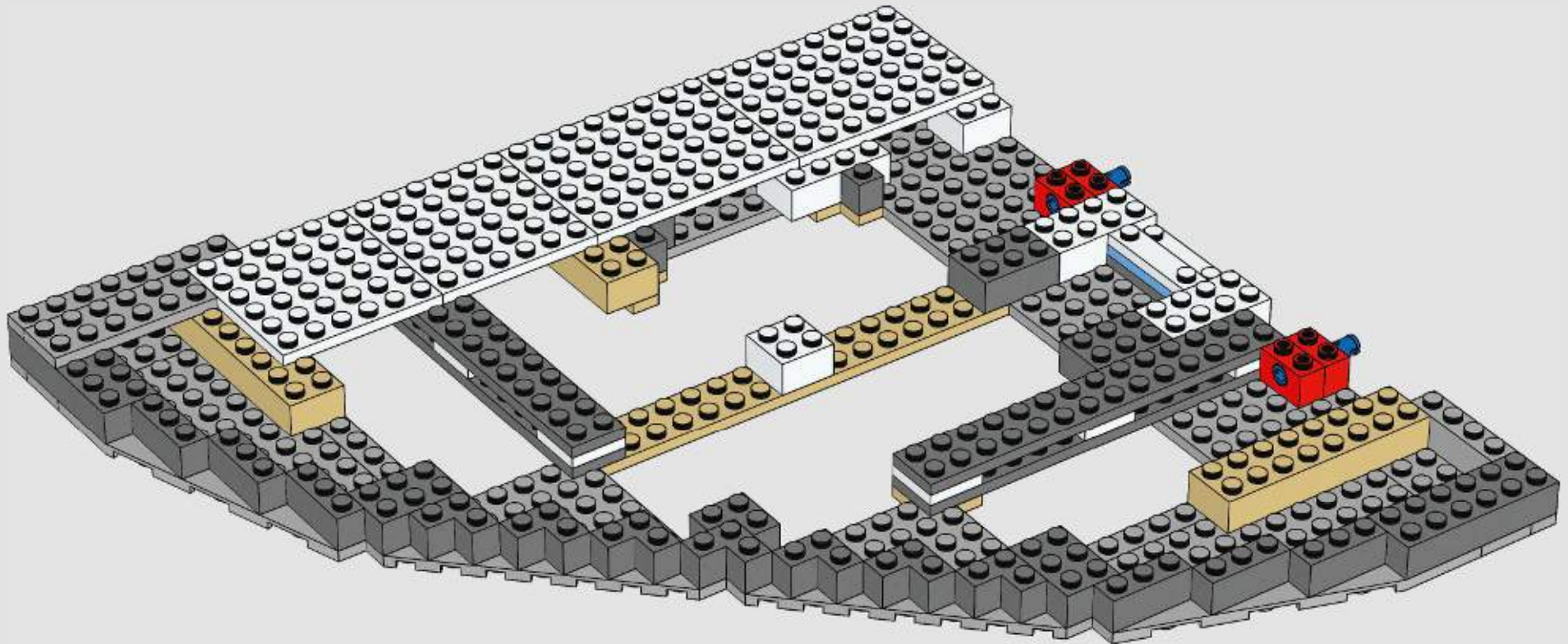

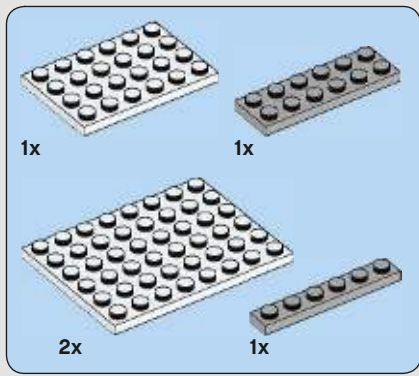

27

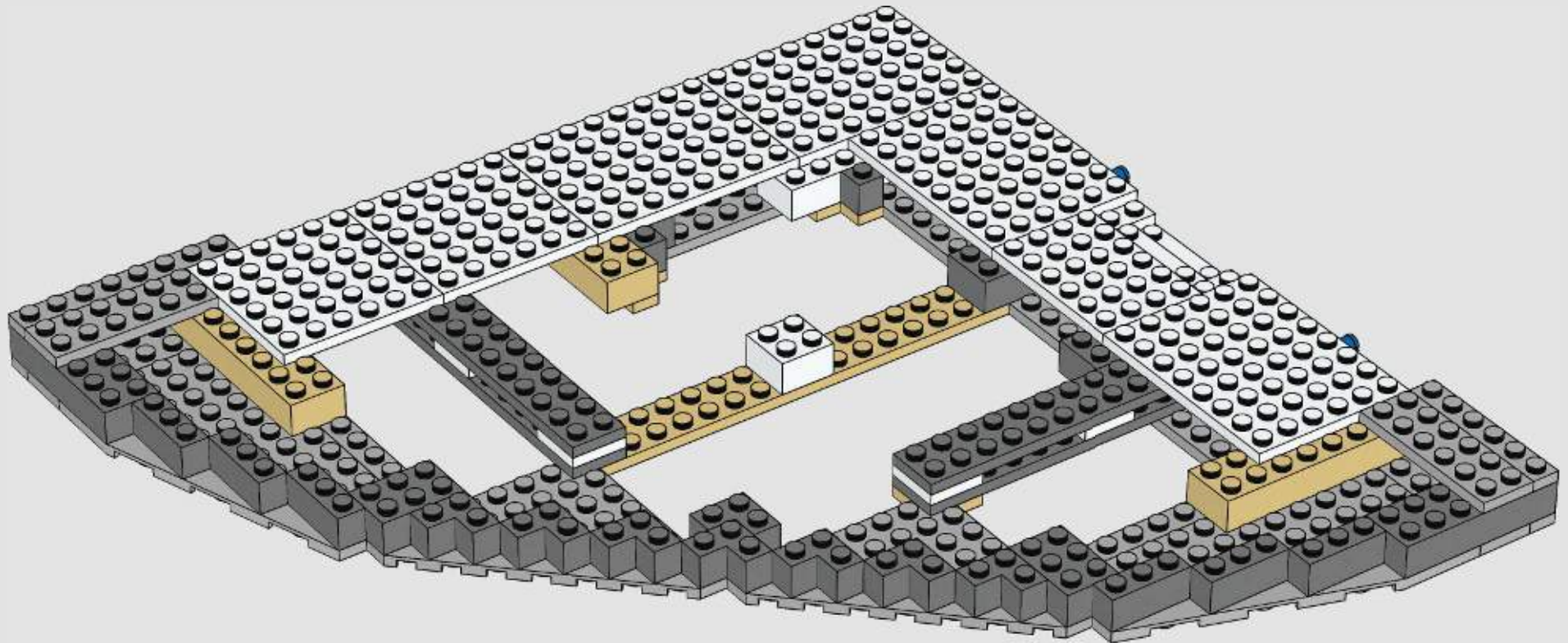



28

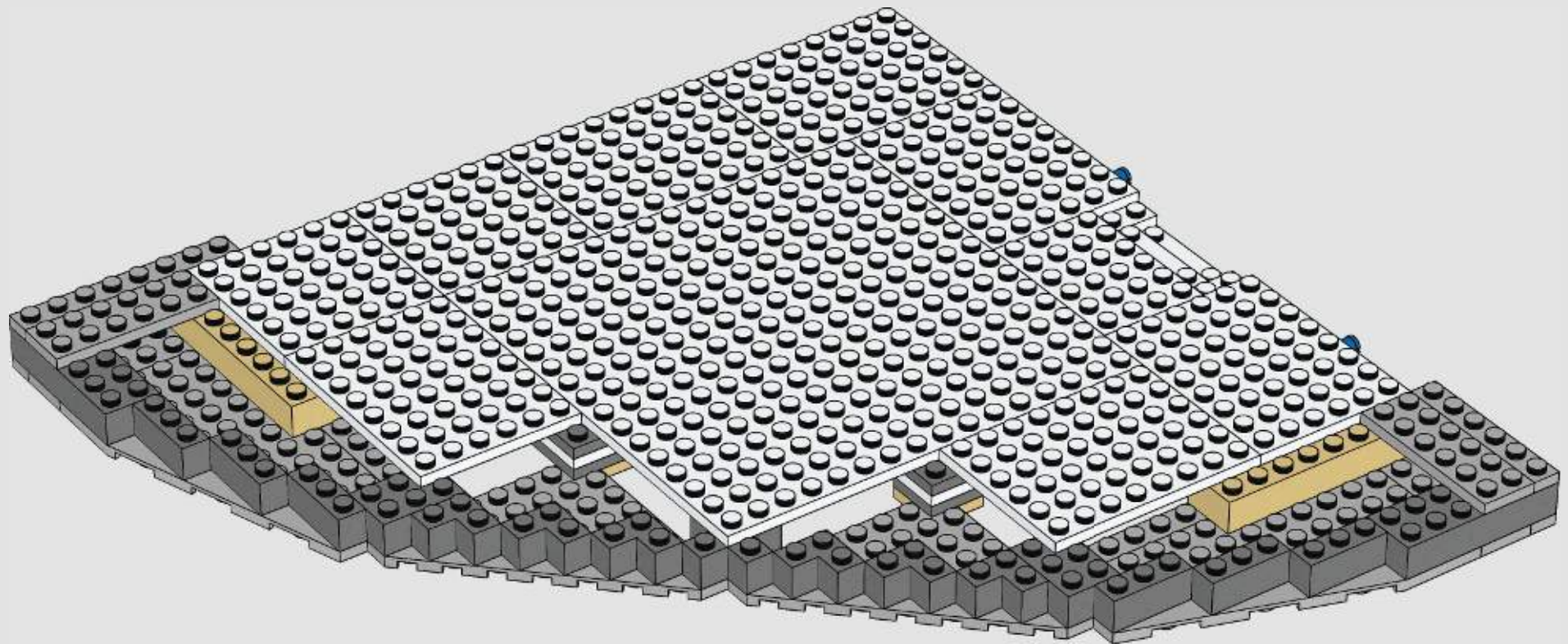

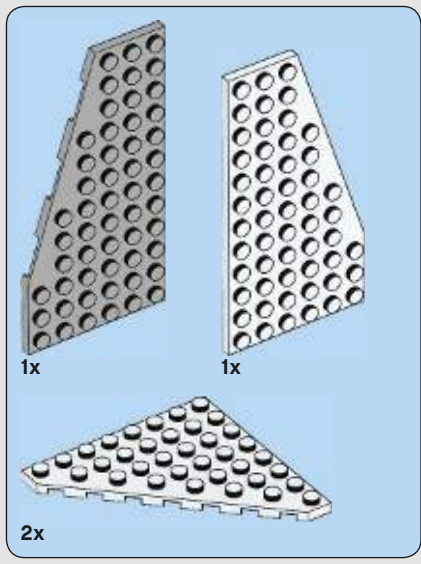

29

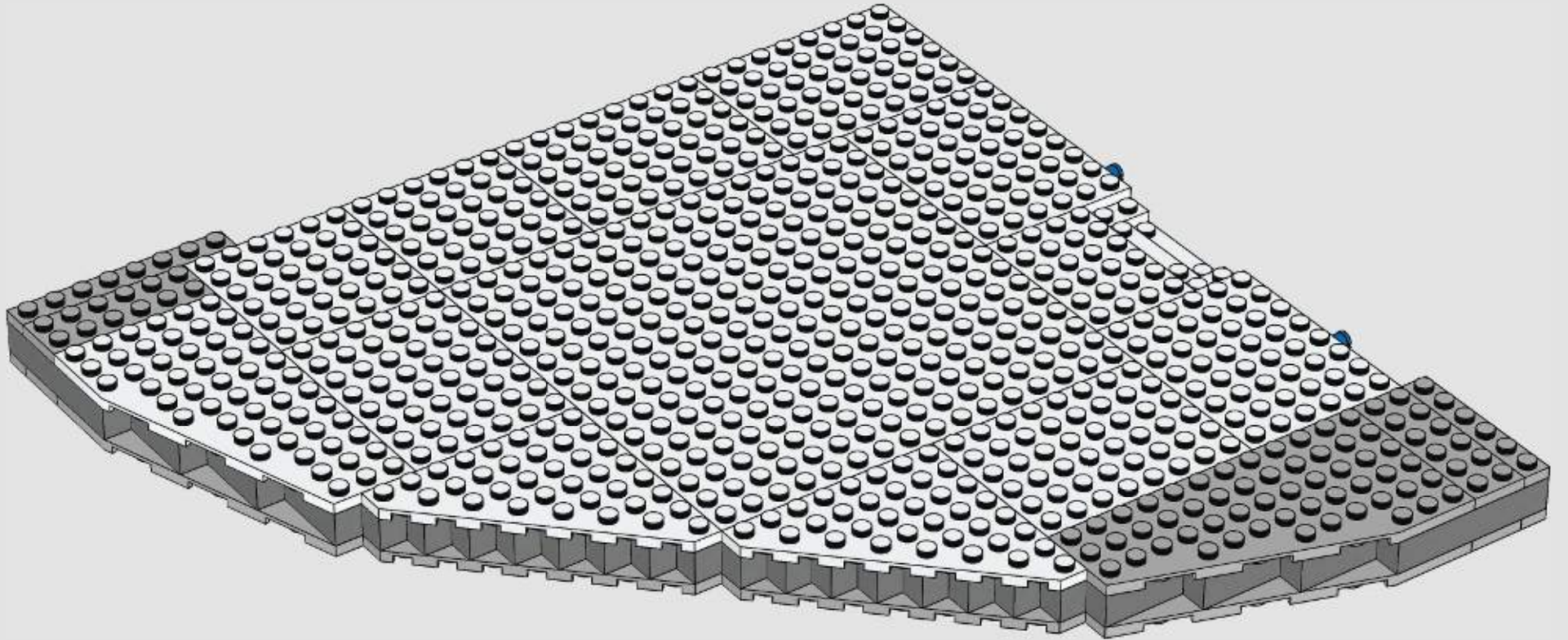



30

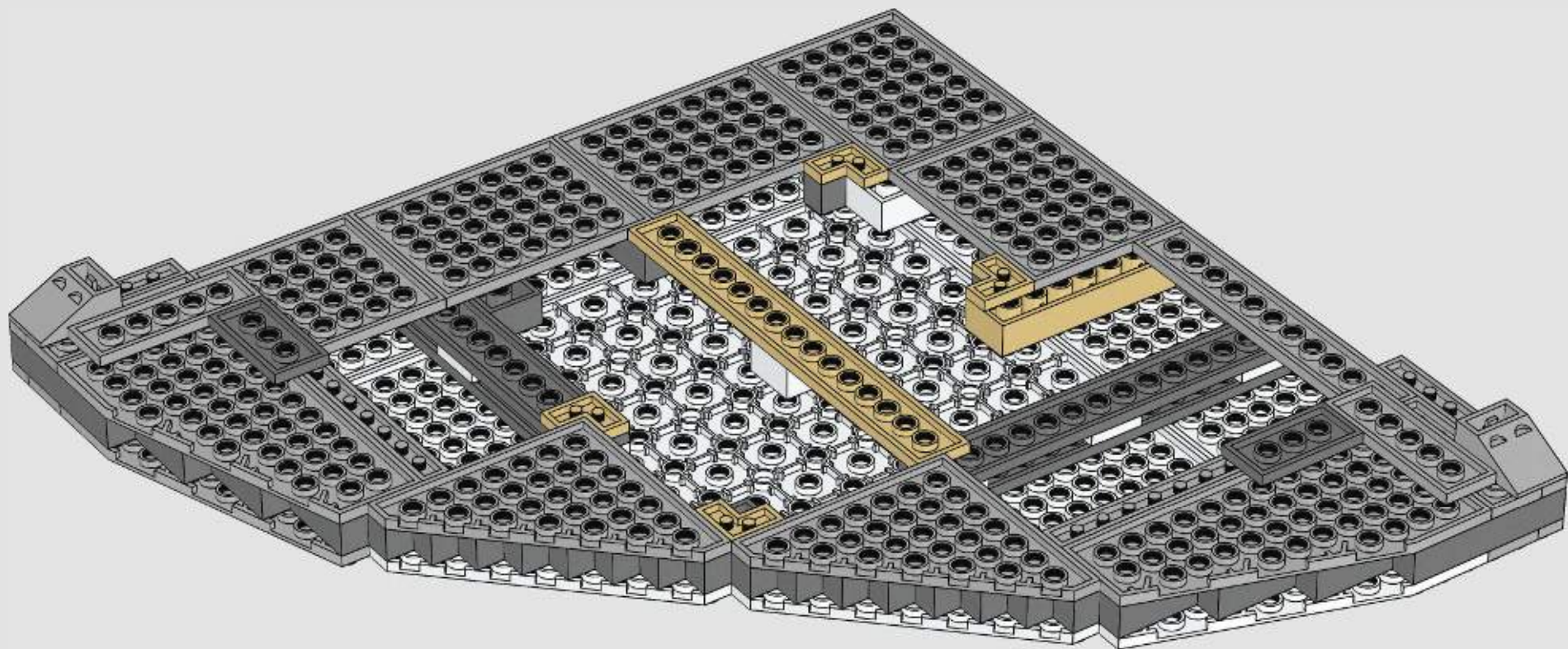
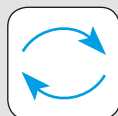

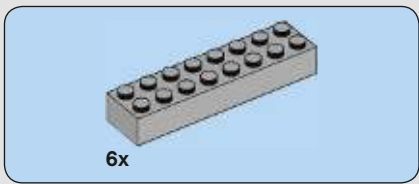

31

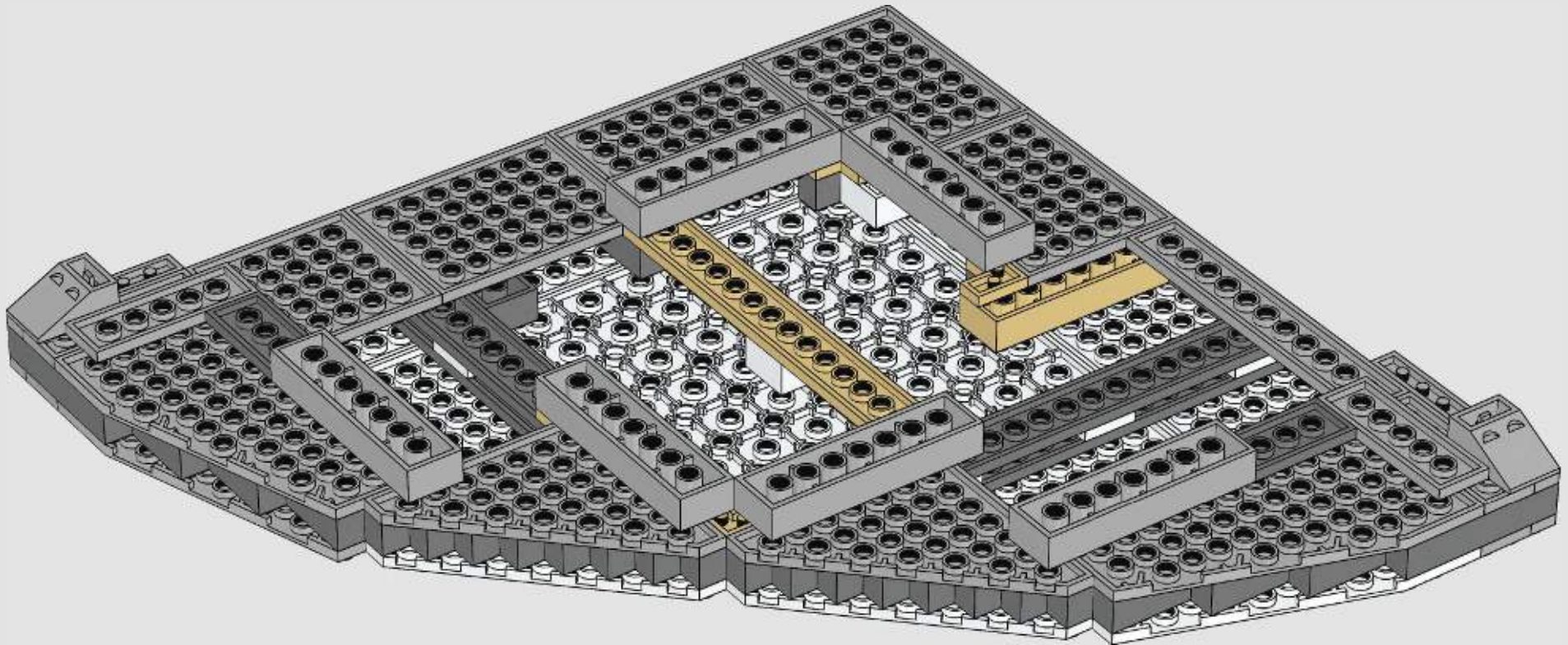

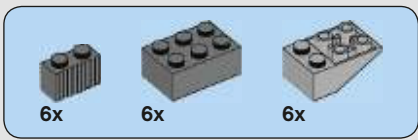

32

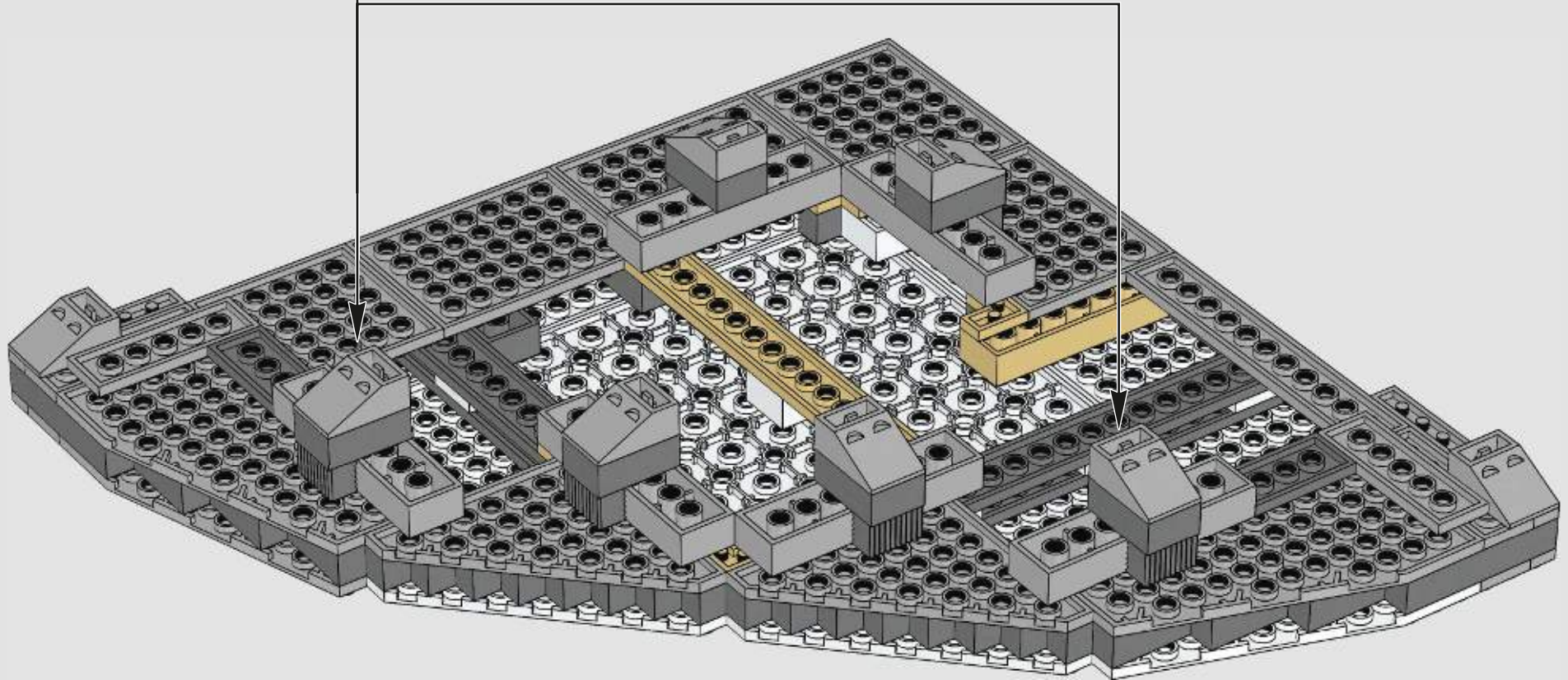
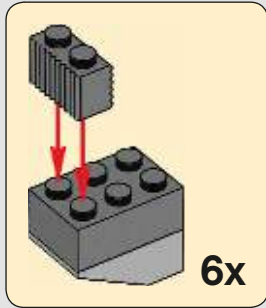

33

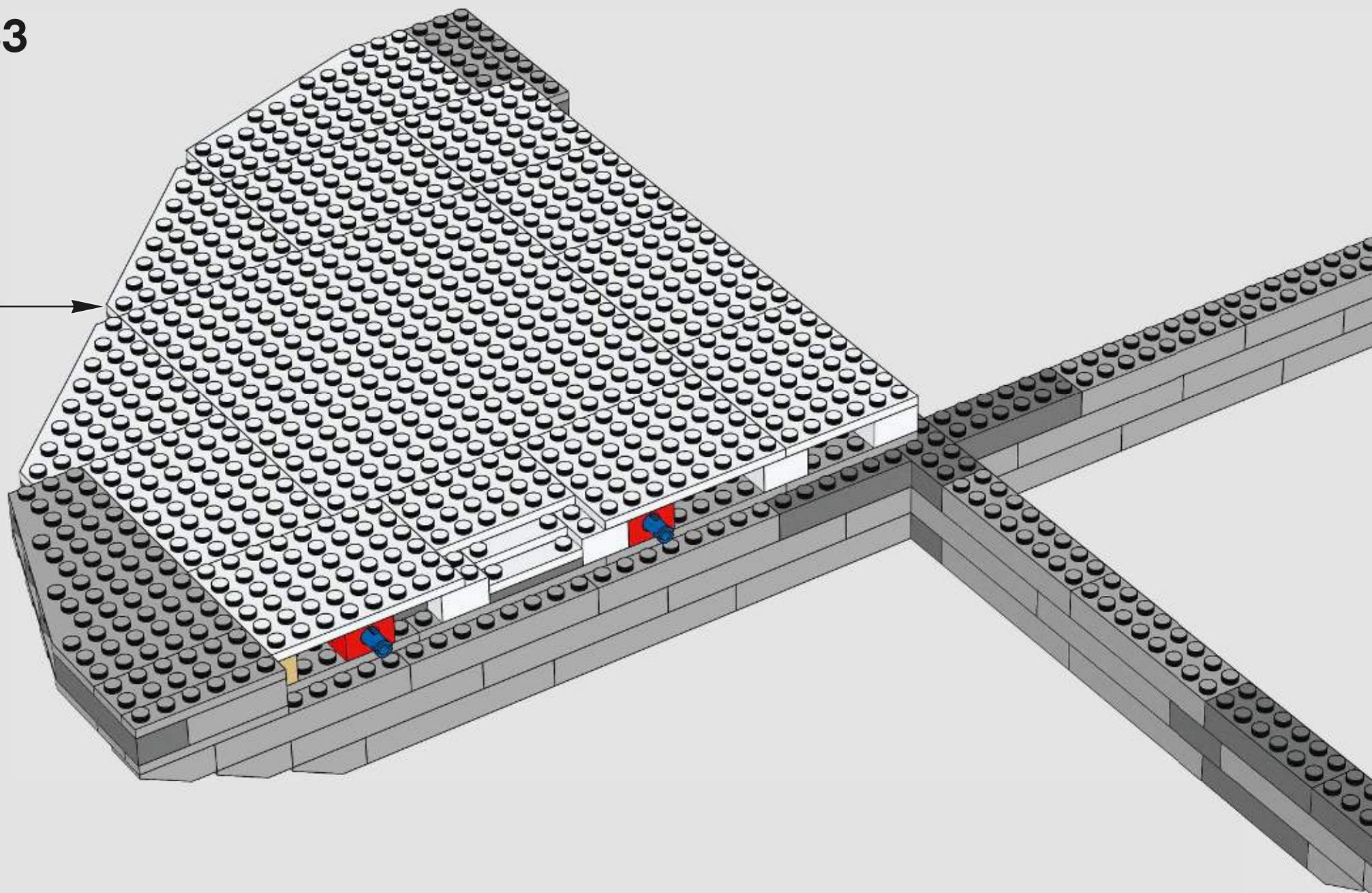

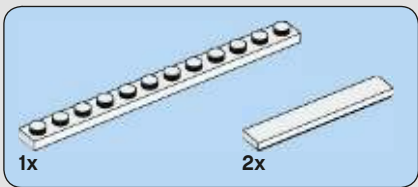

34

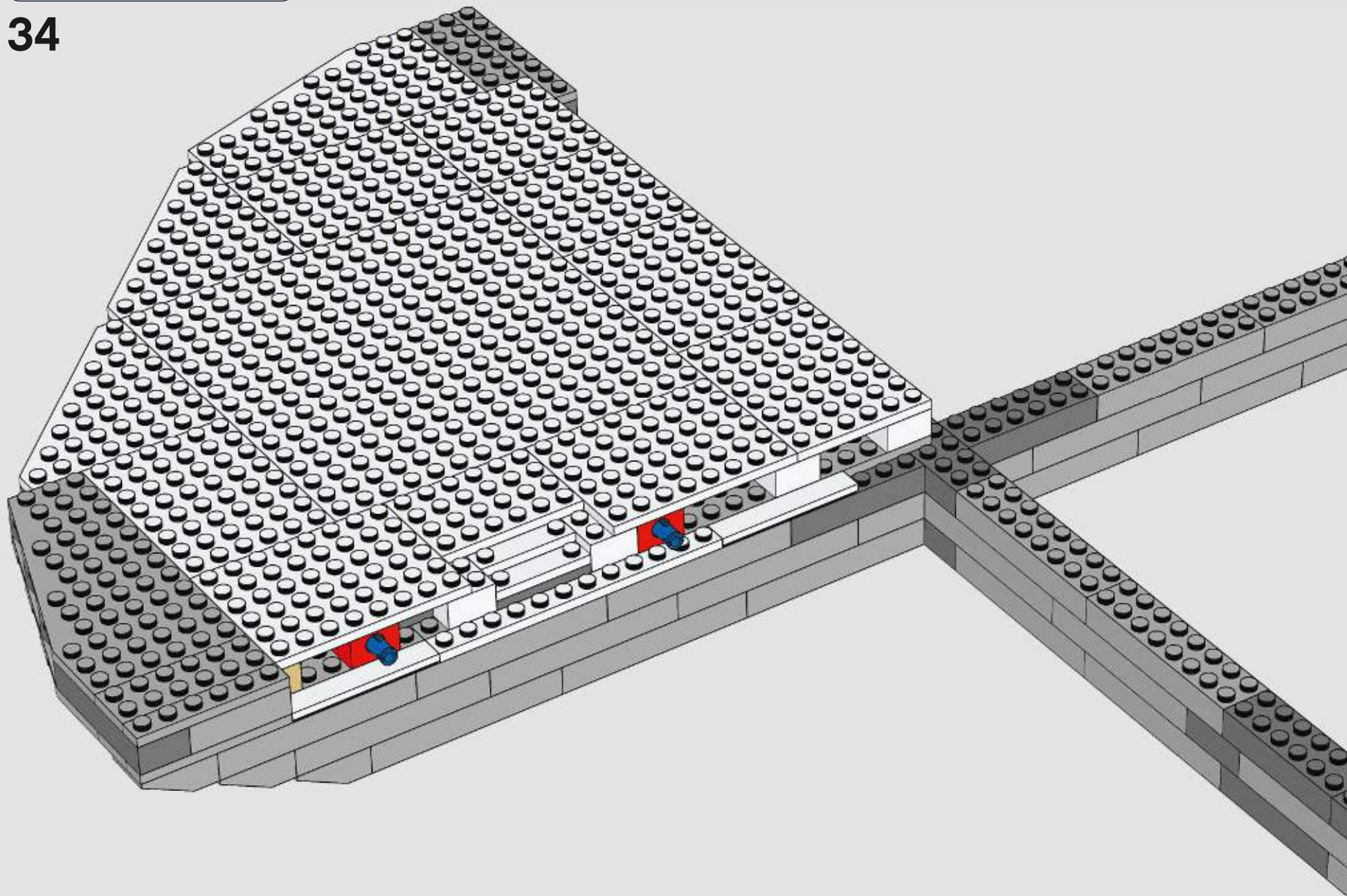

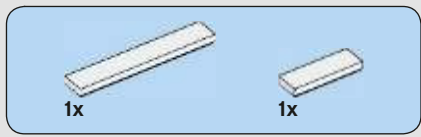

35

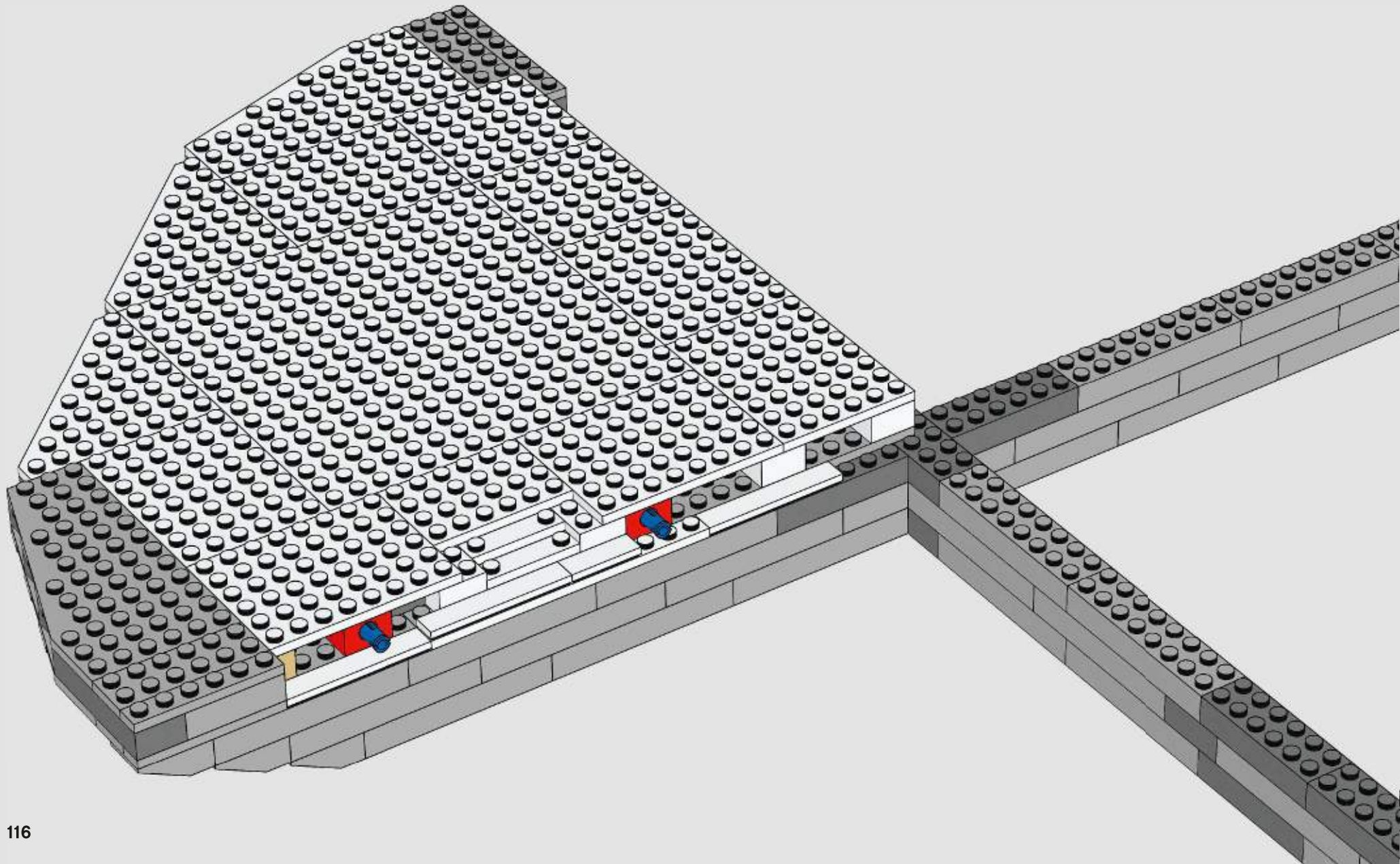

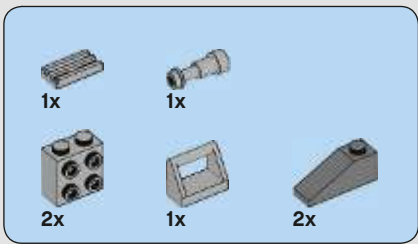

36

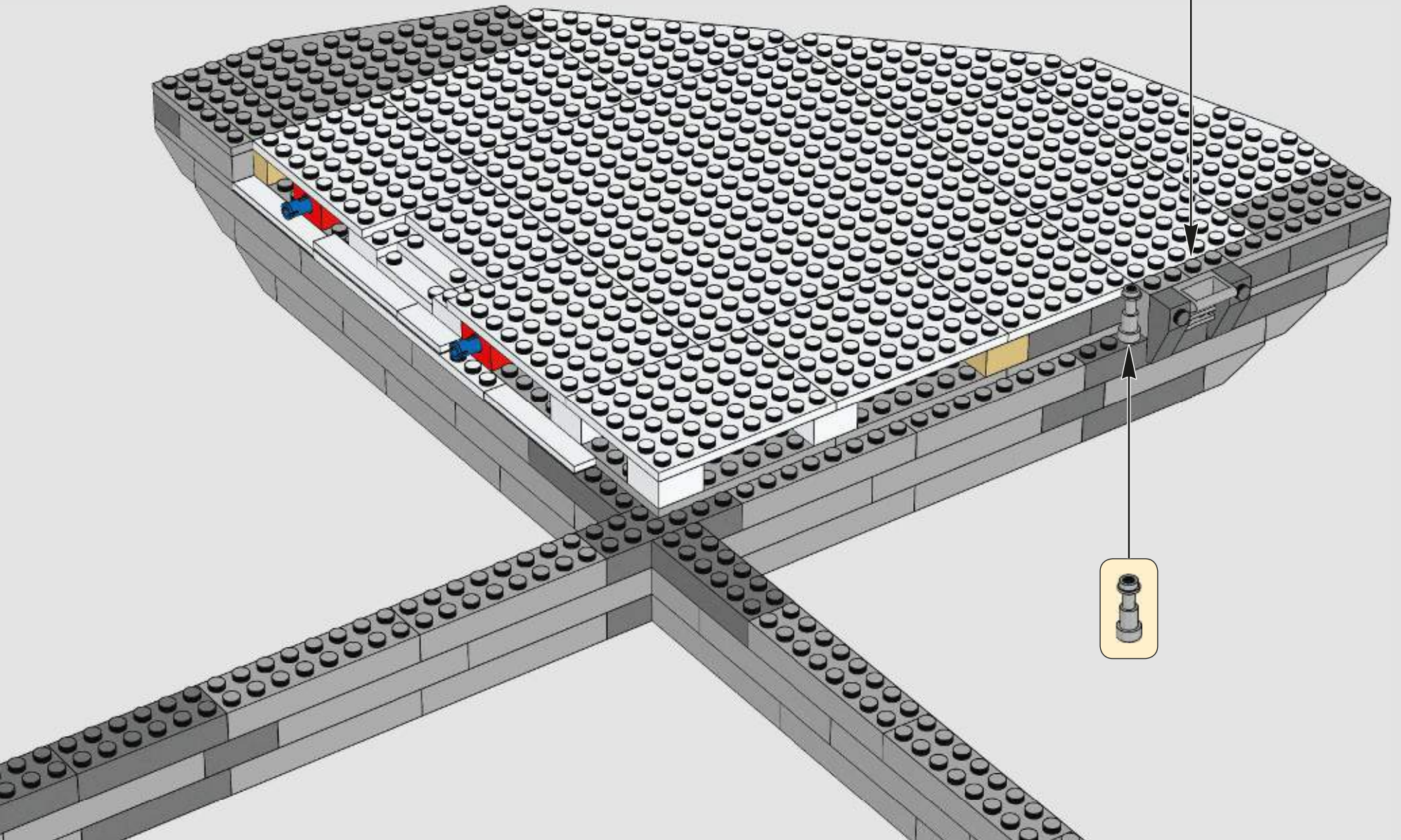
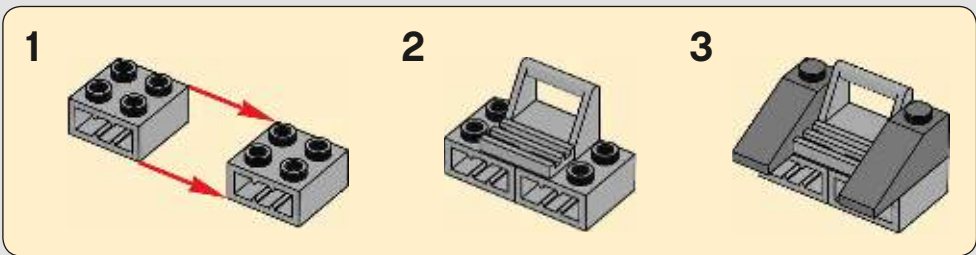

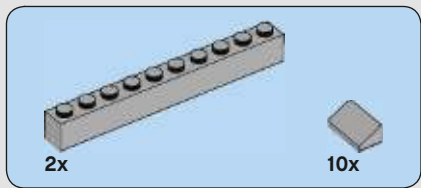

37

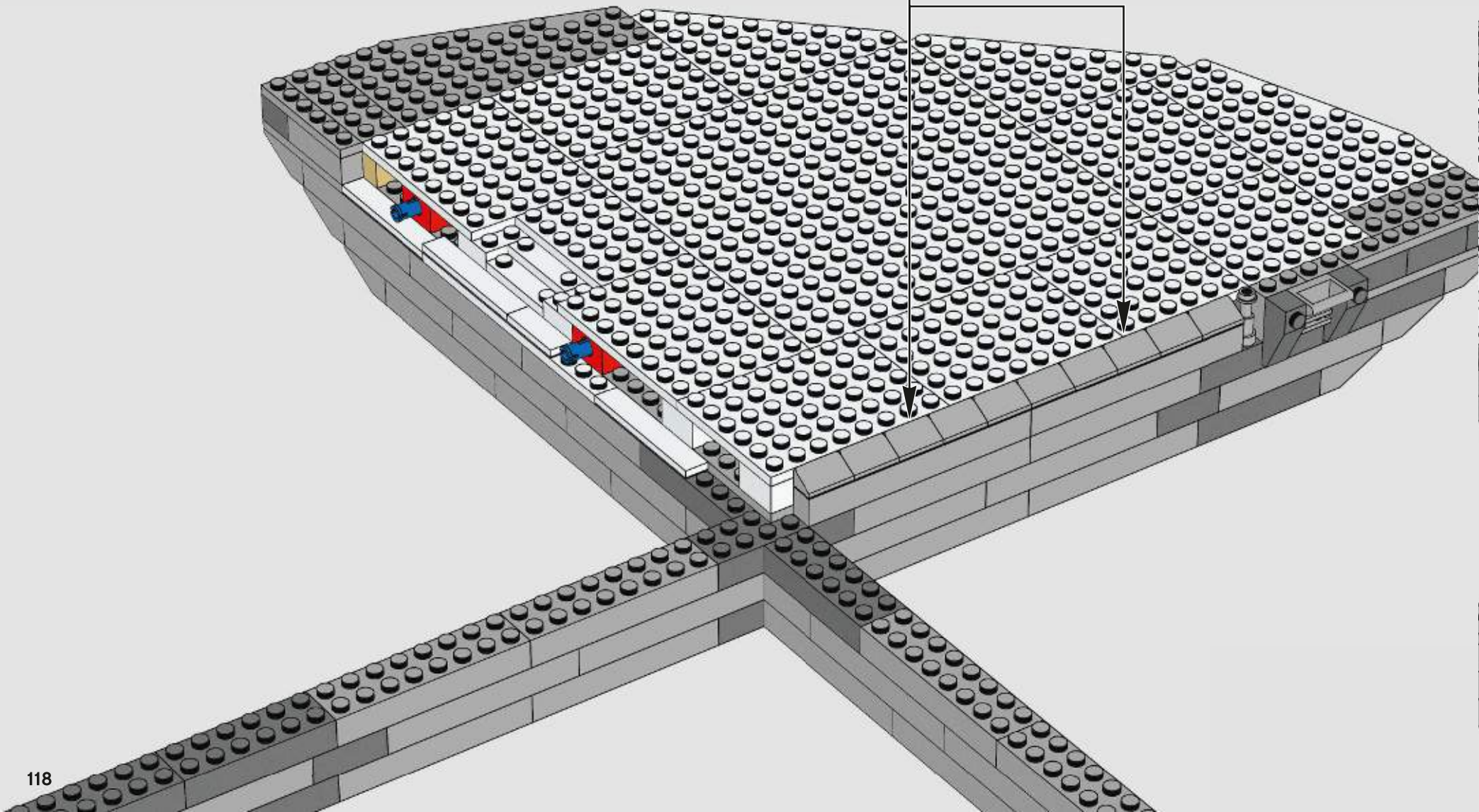
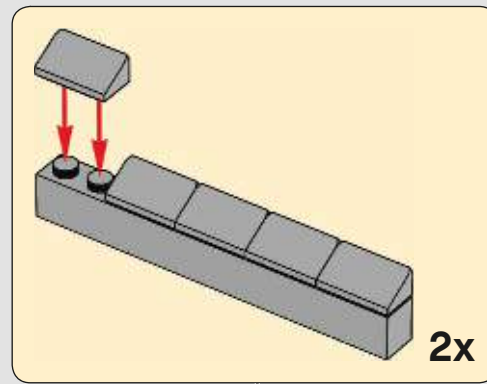

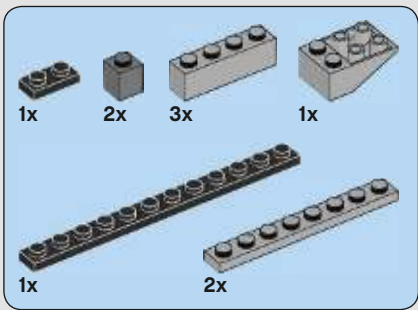

38

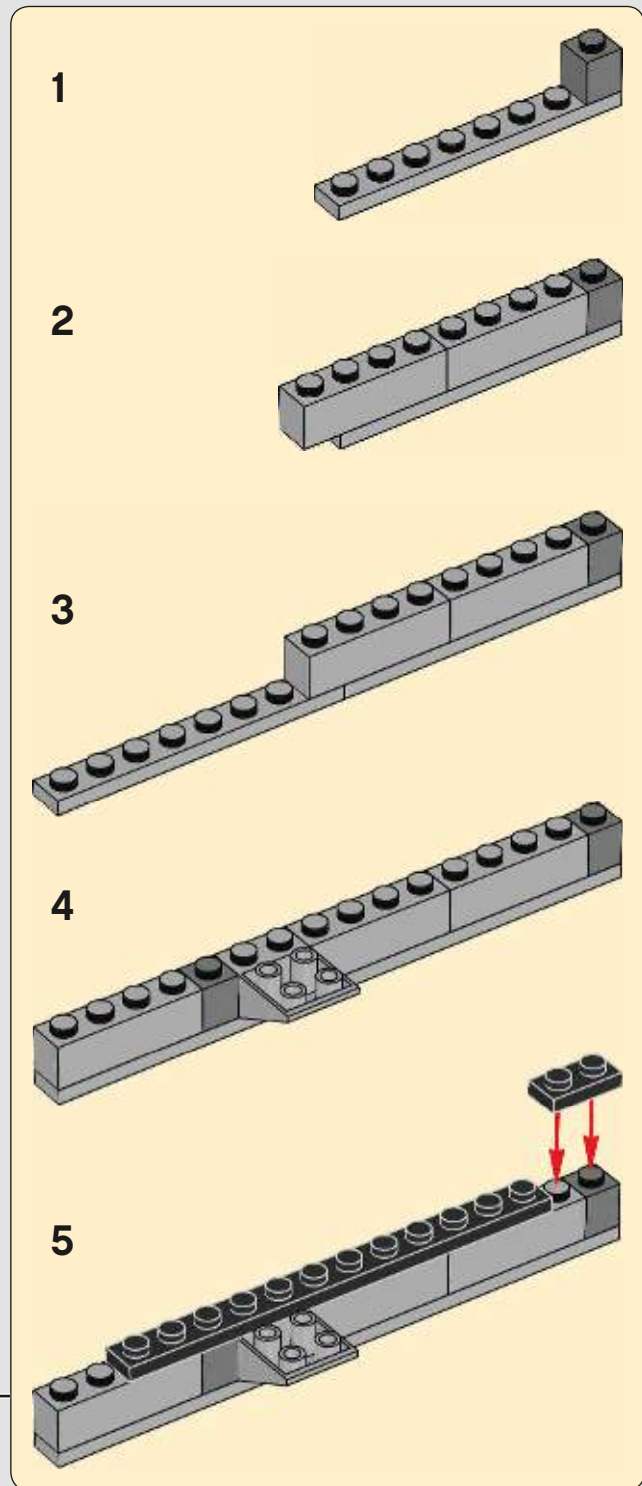
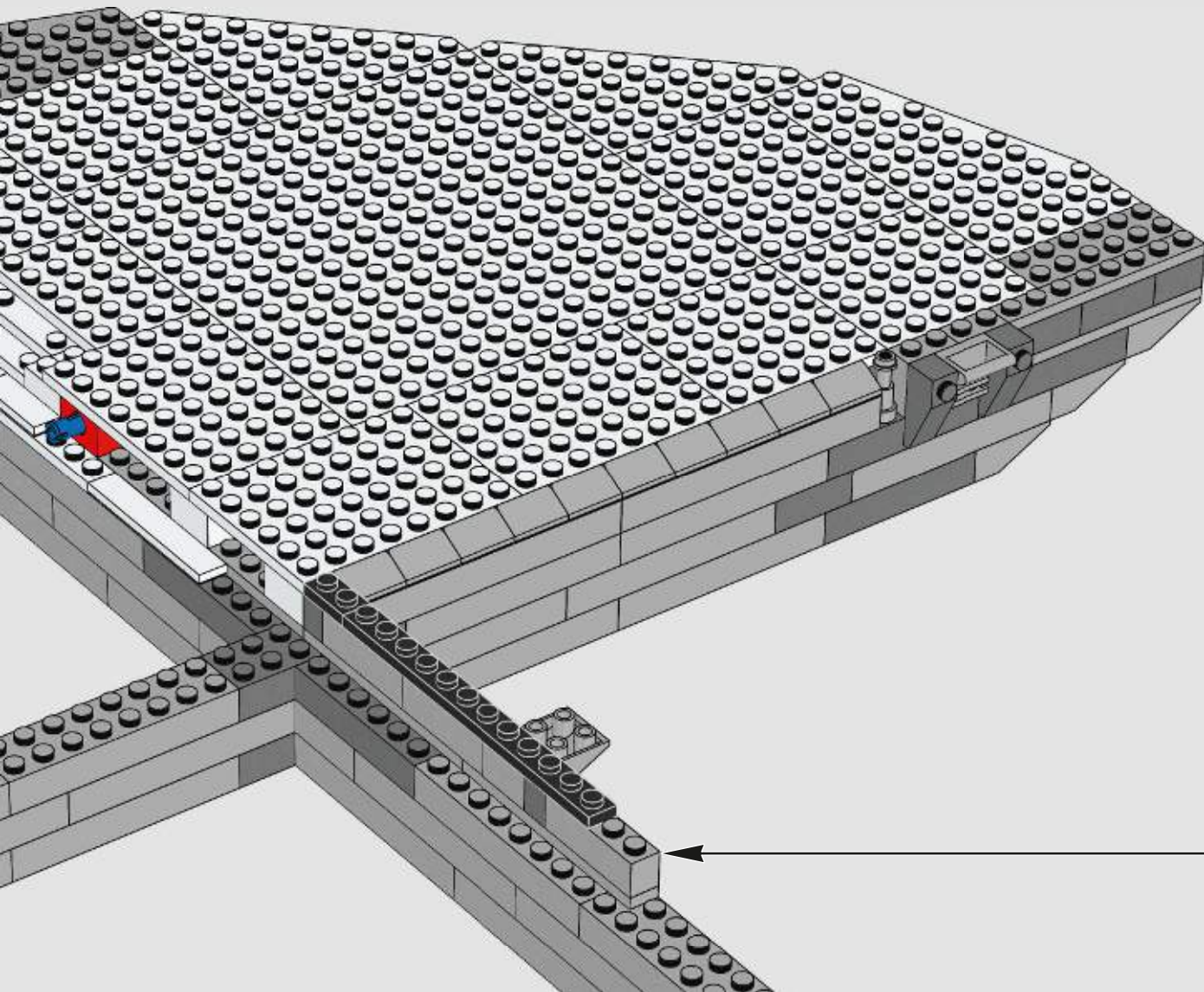

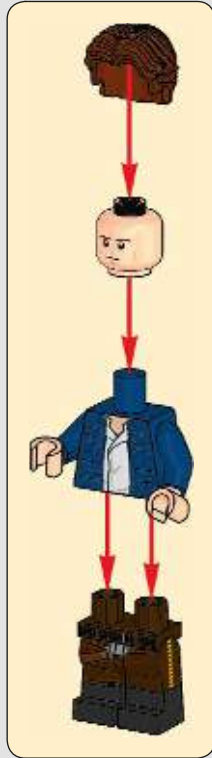
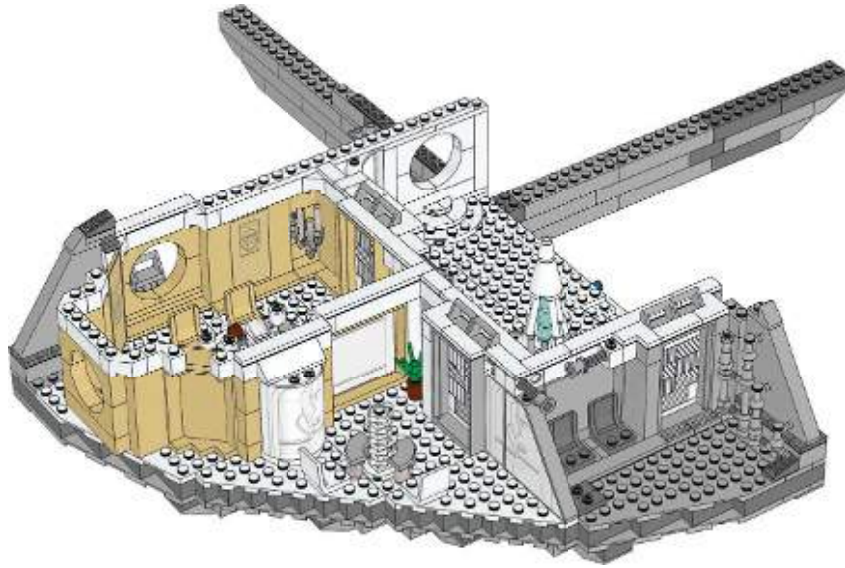

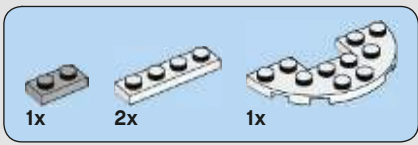

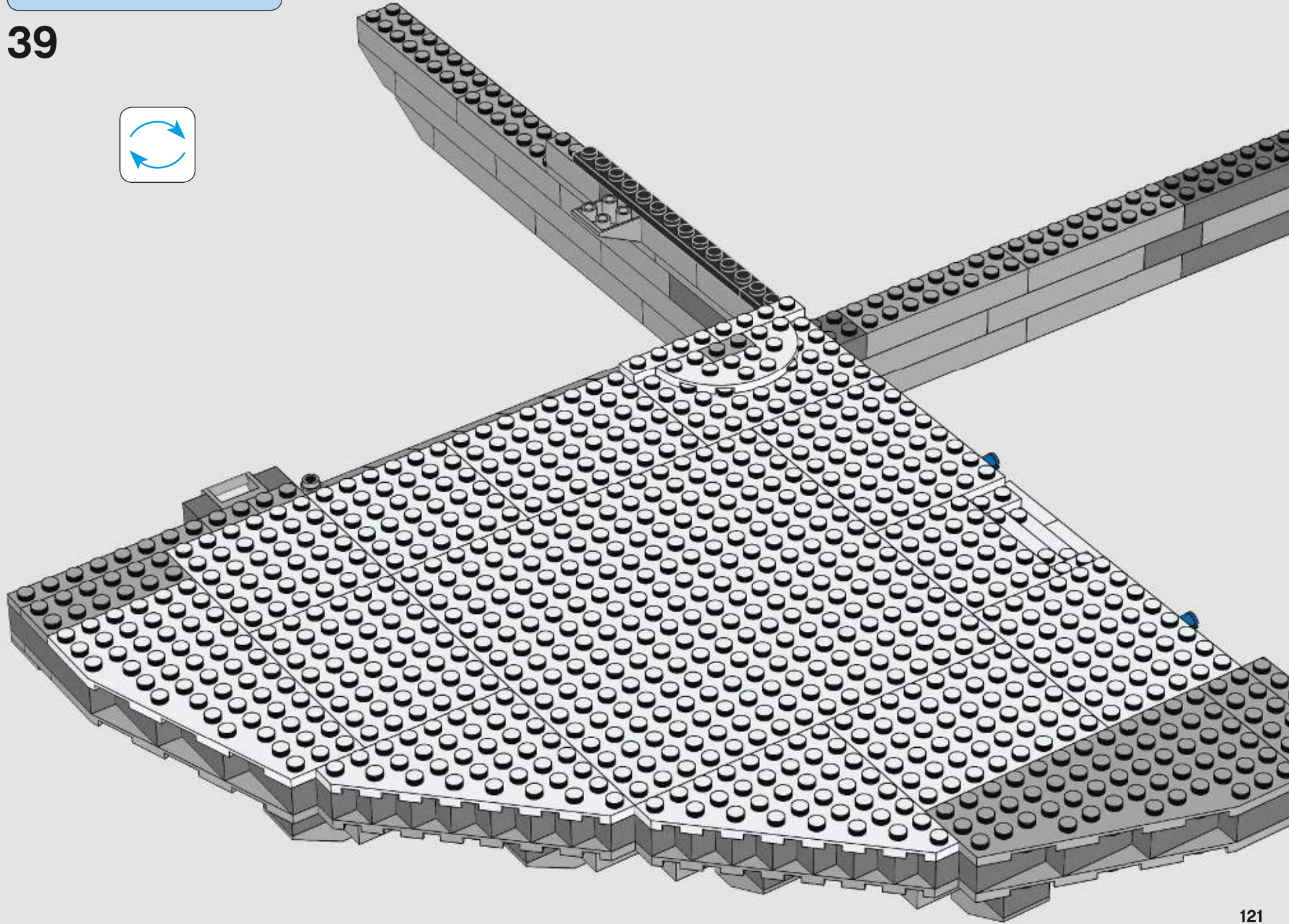

39



2x  2x  1x 

40

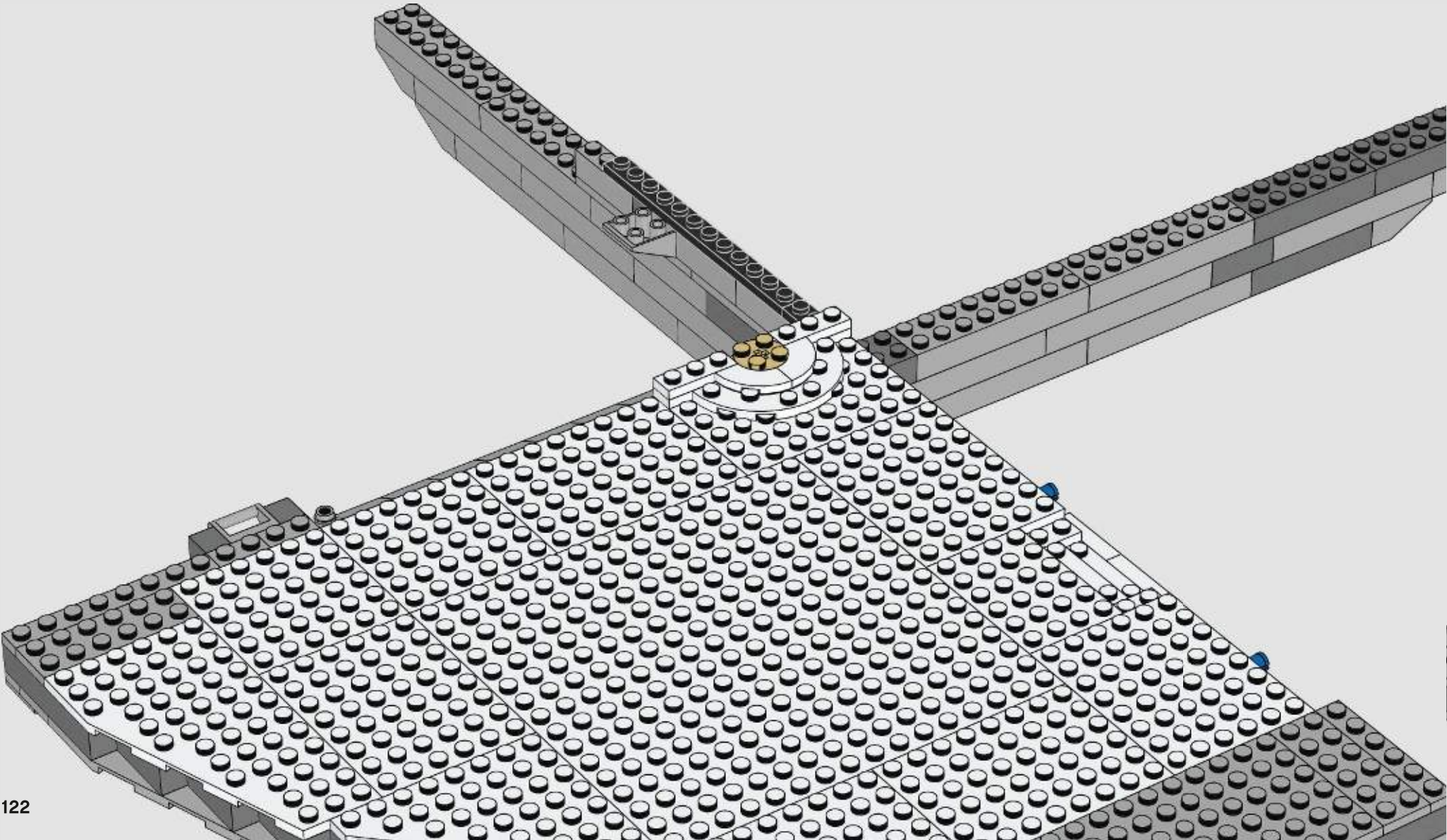

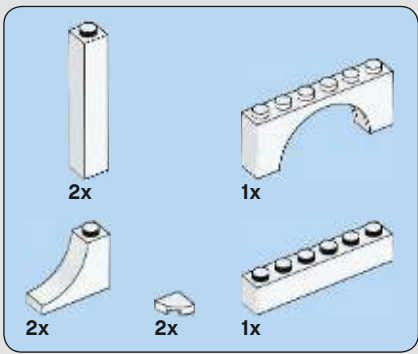

41

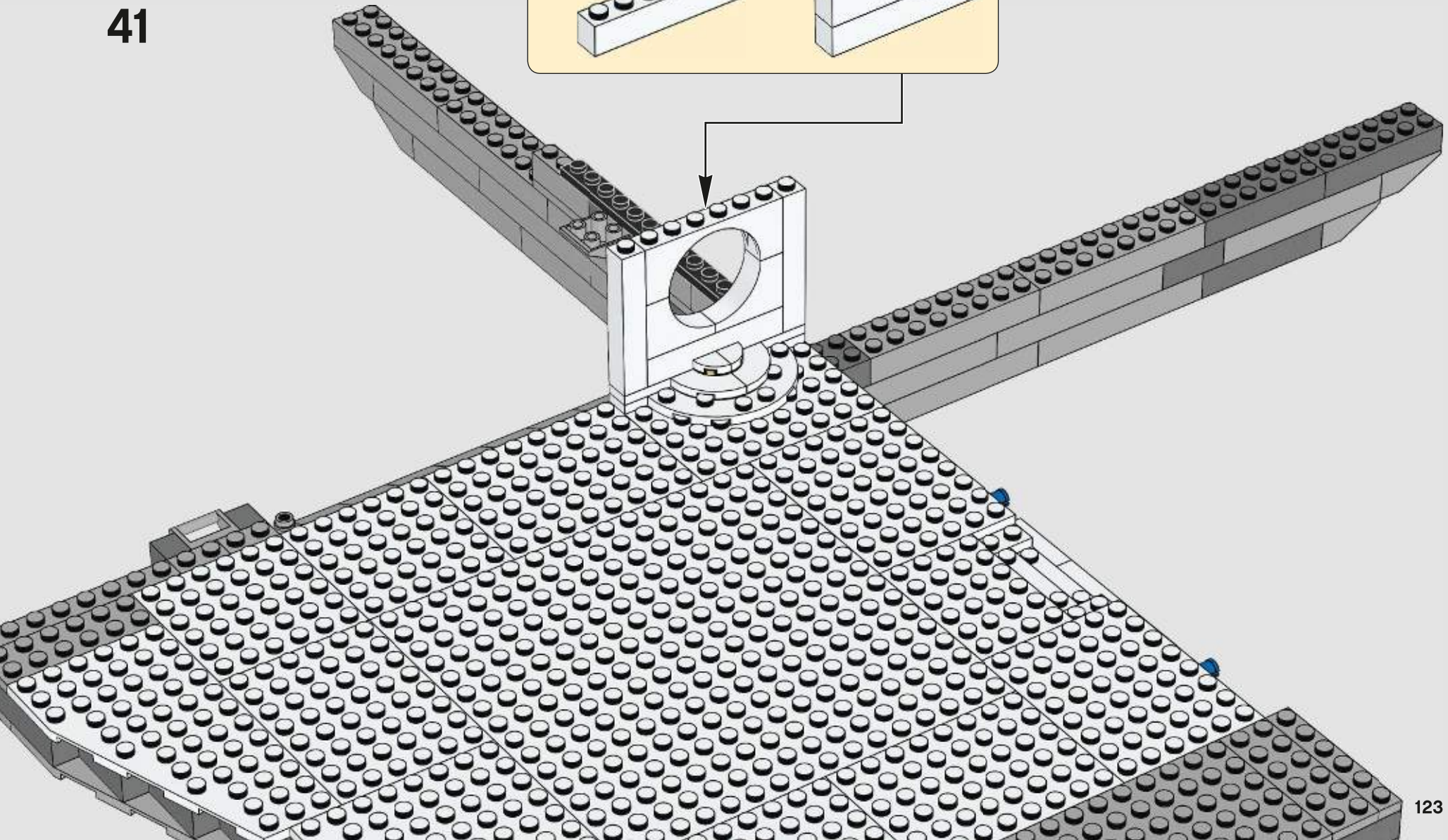
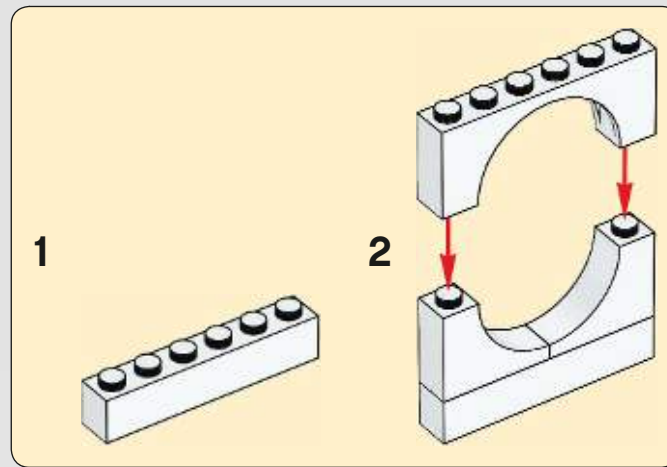

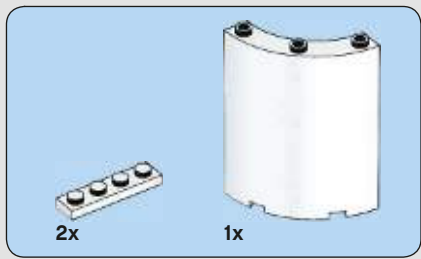

42

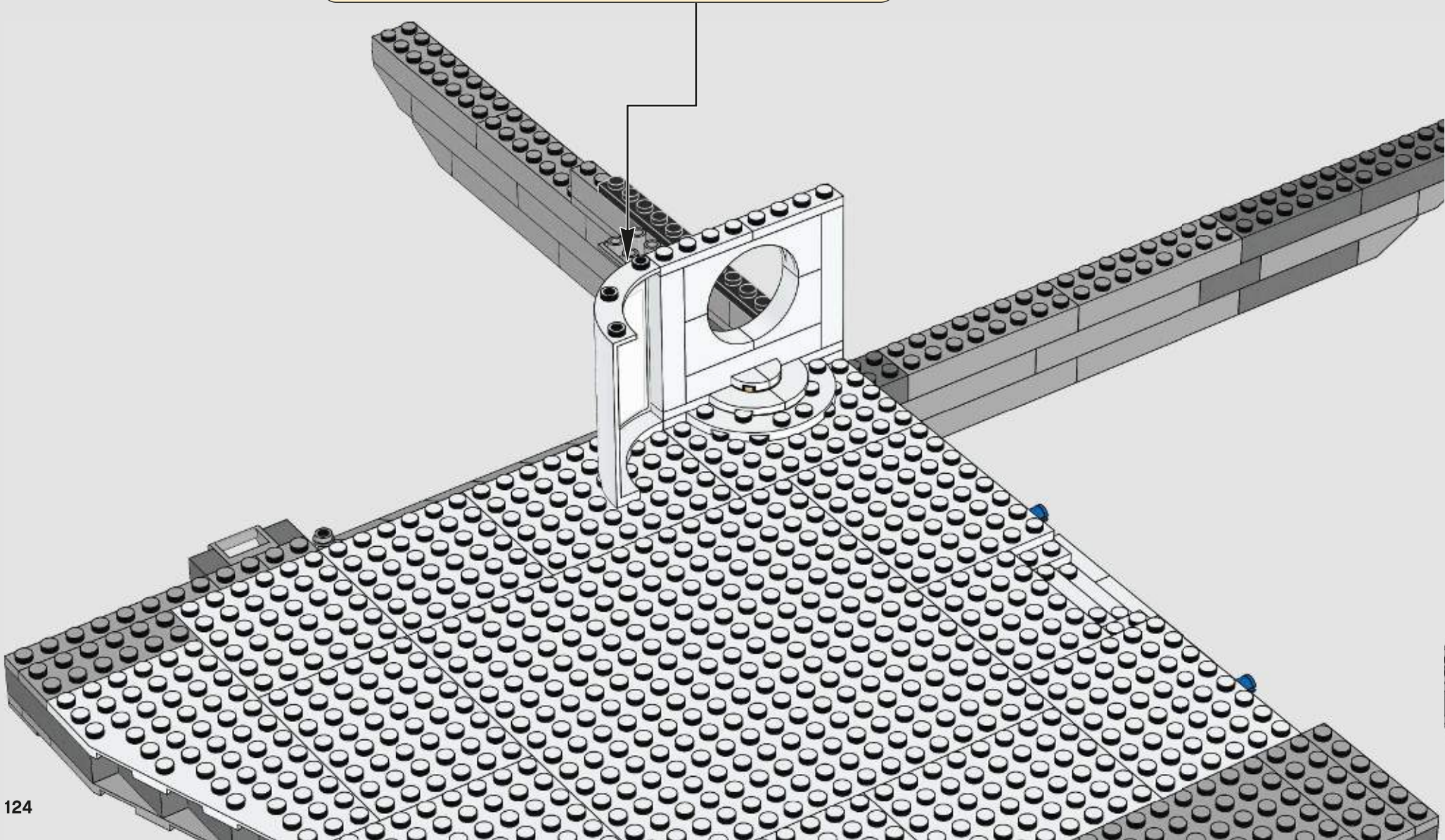
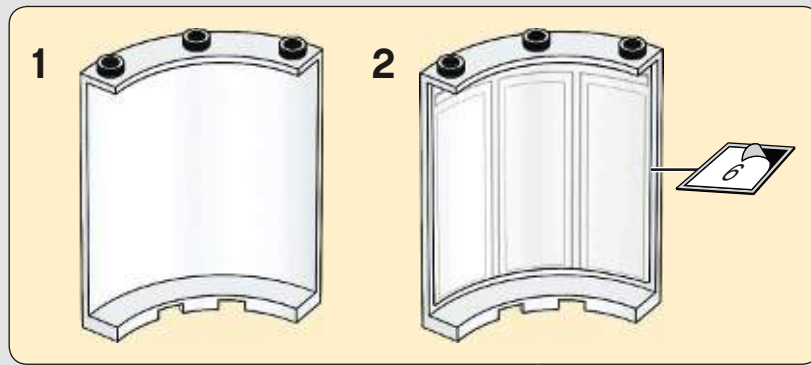

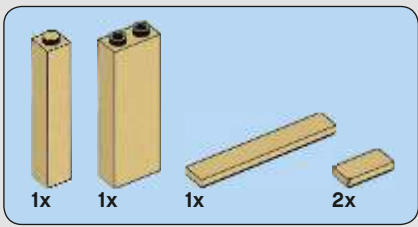

43

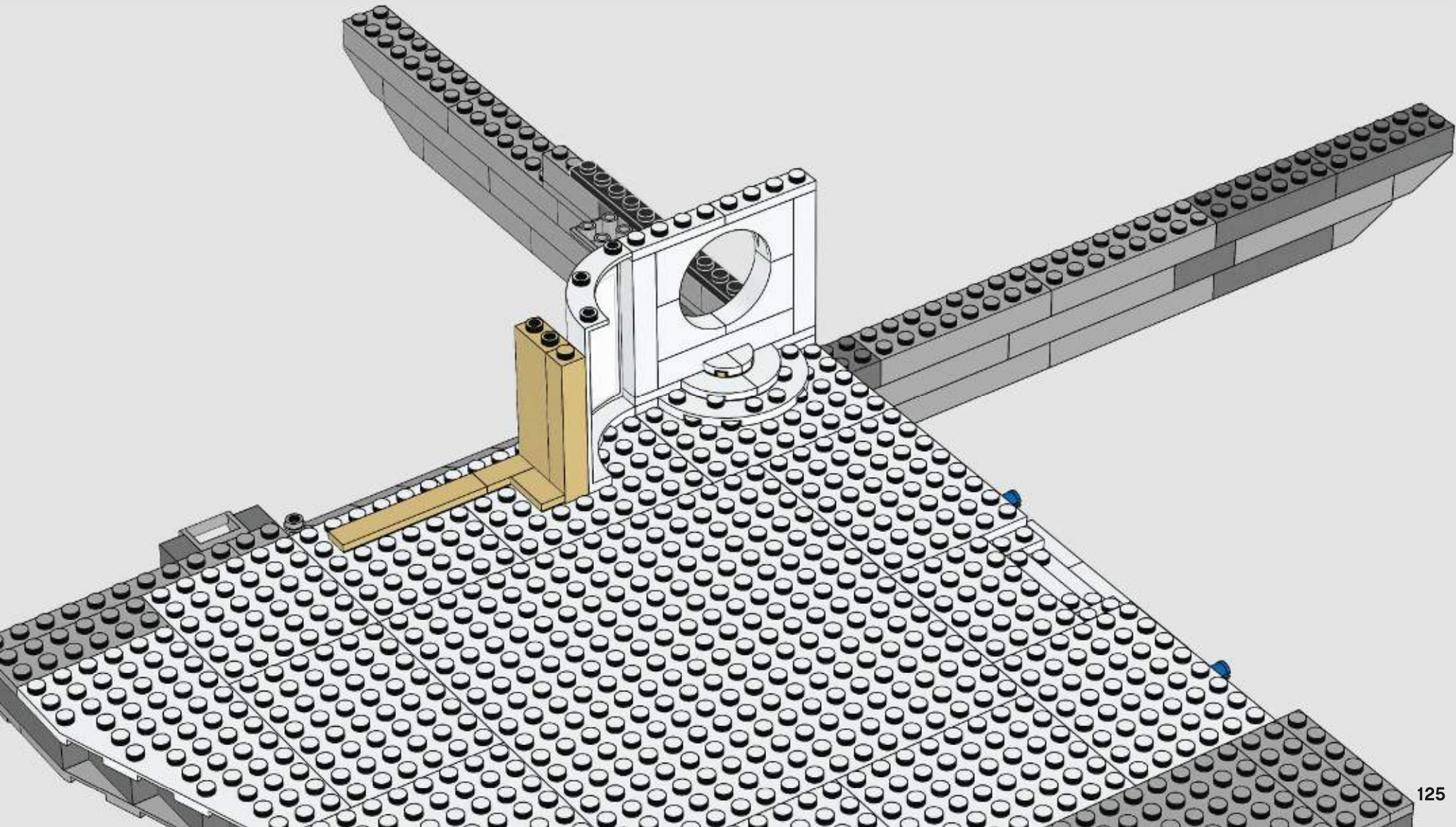

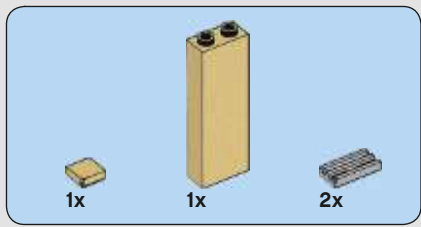

44

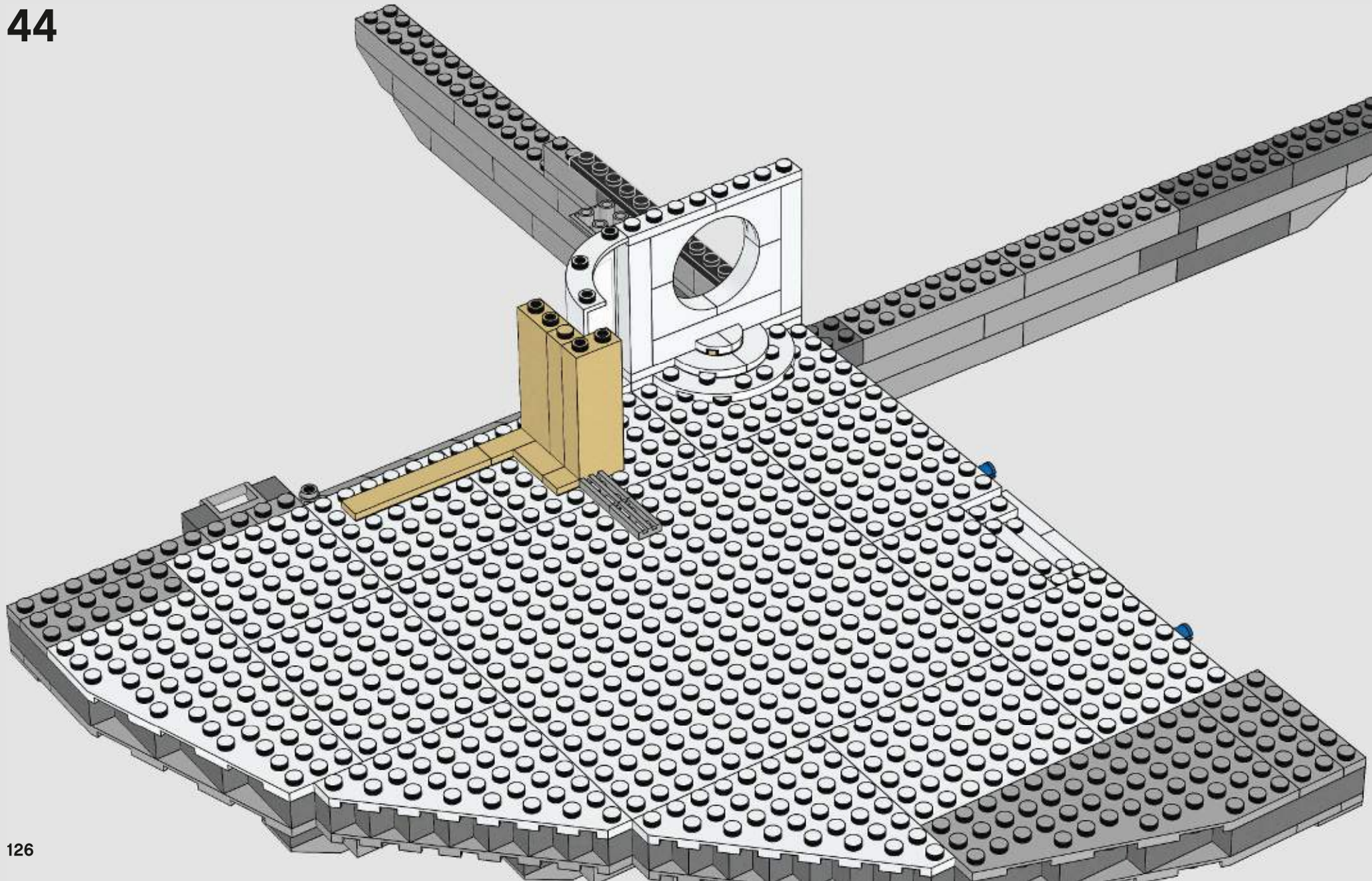

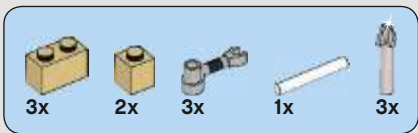

45

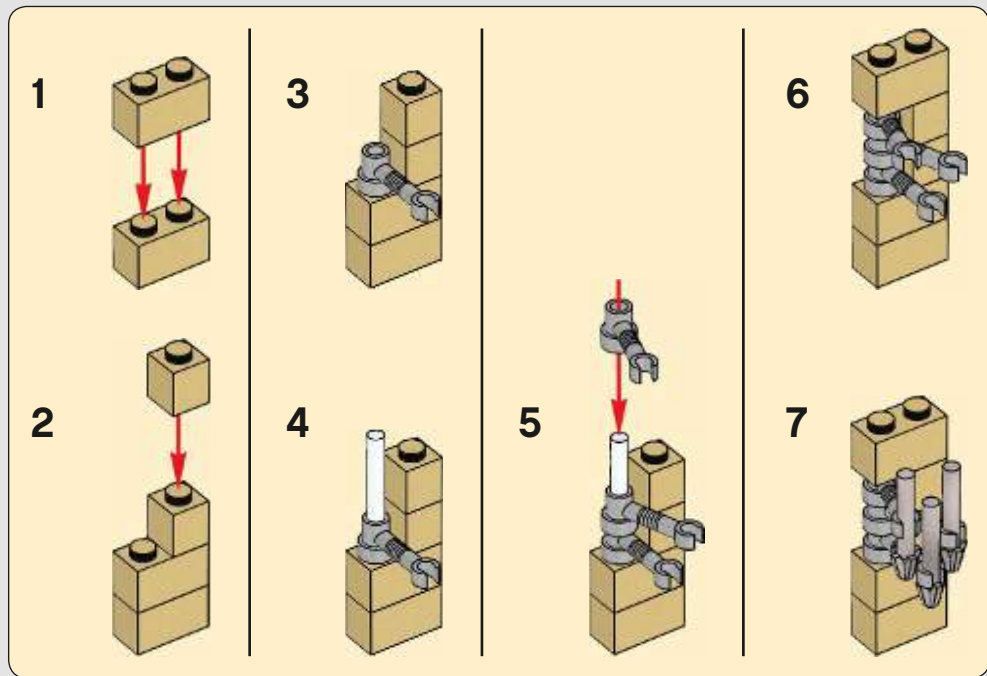
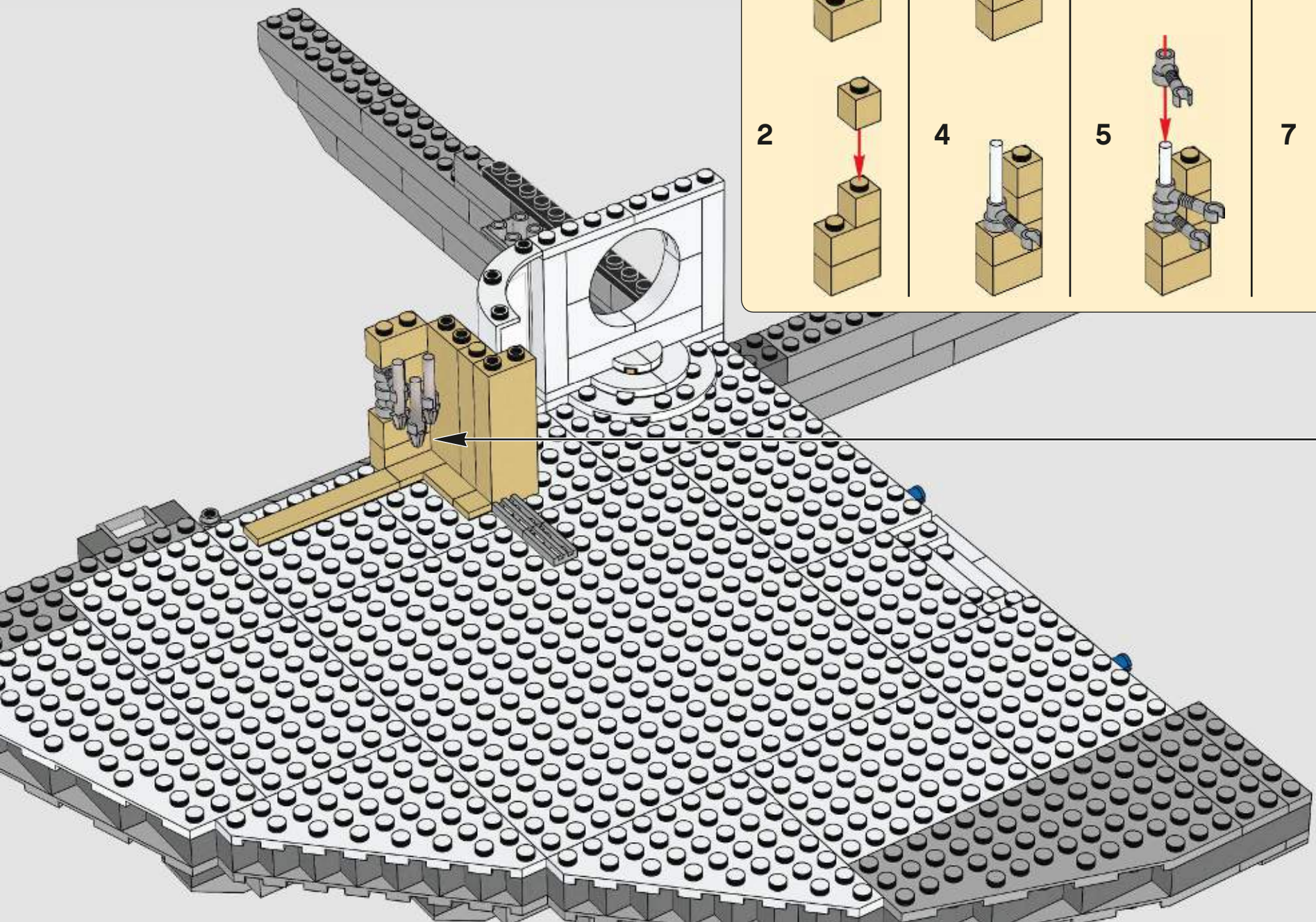

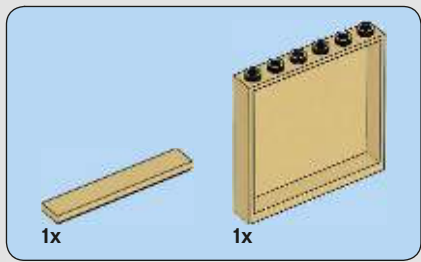

46

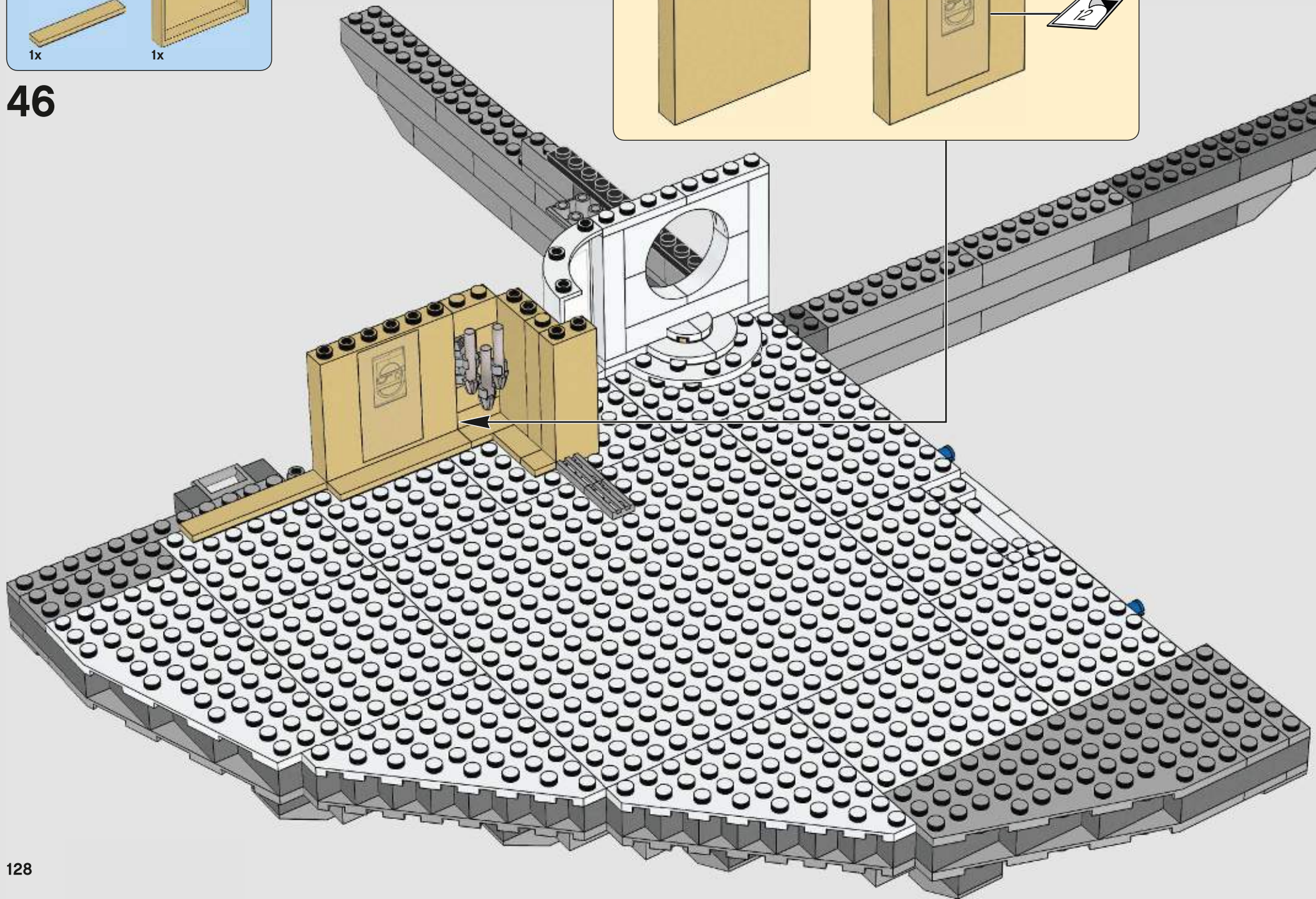
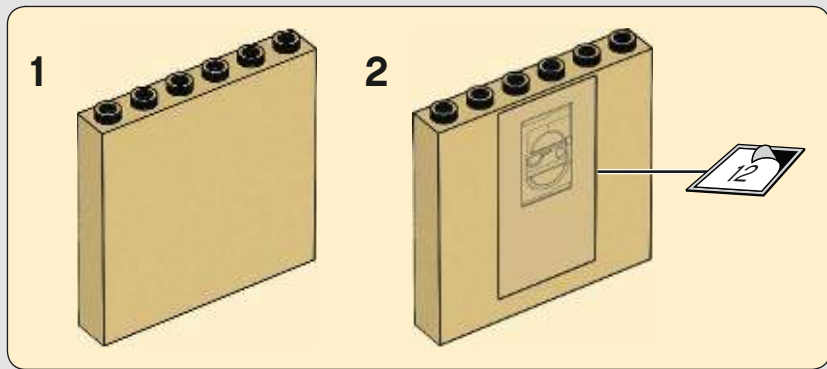

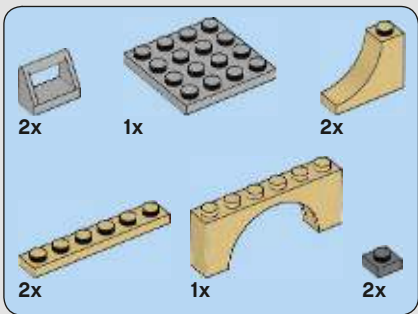

47

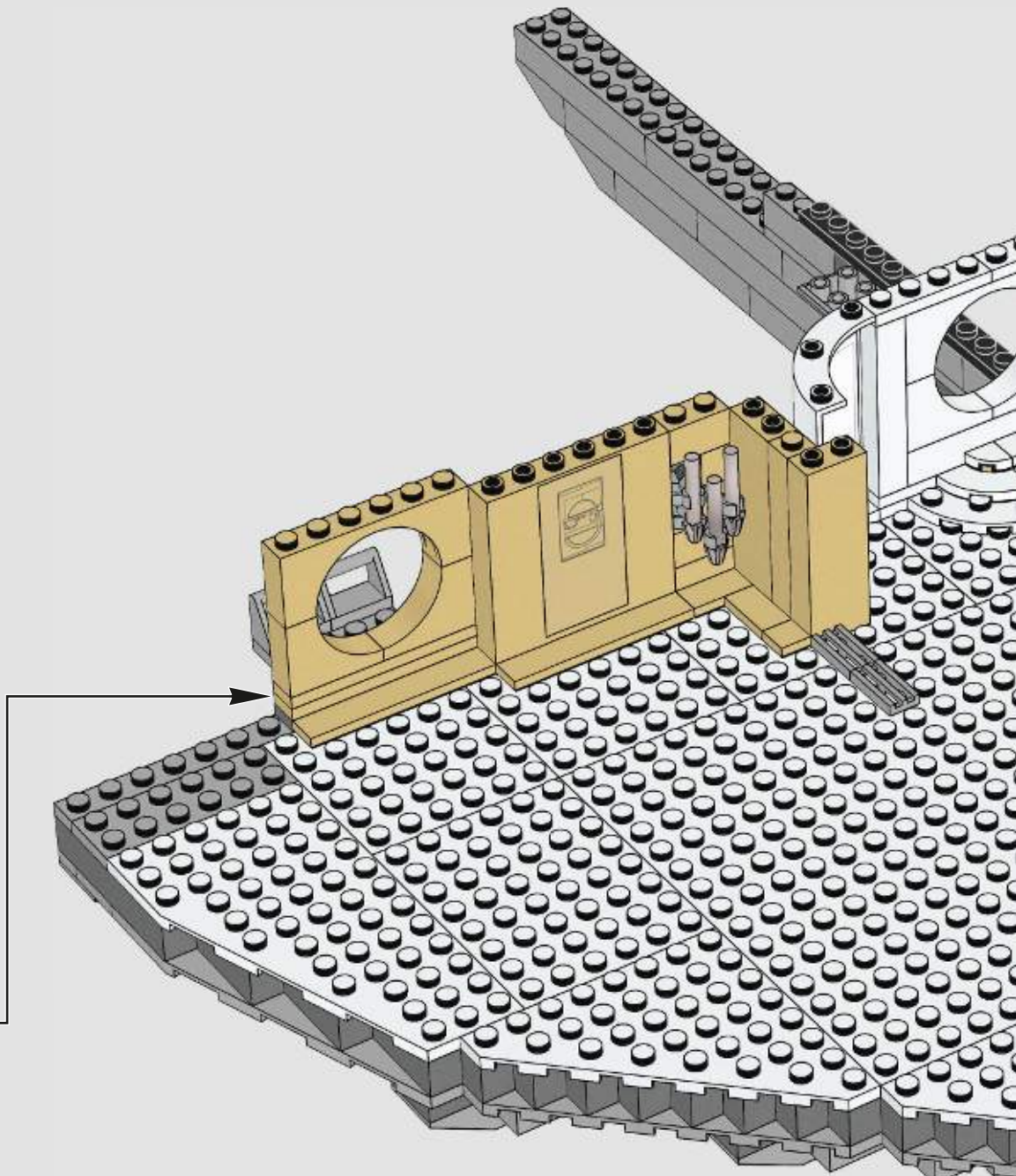
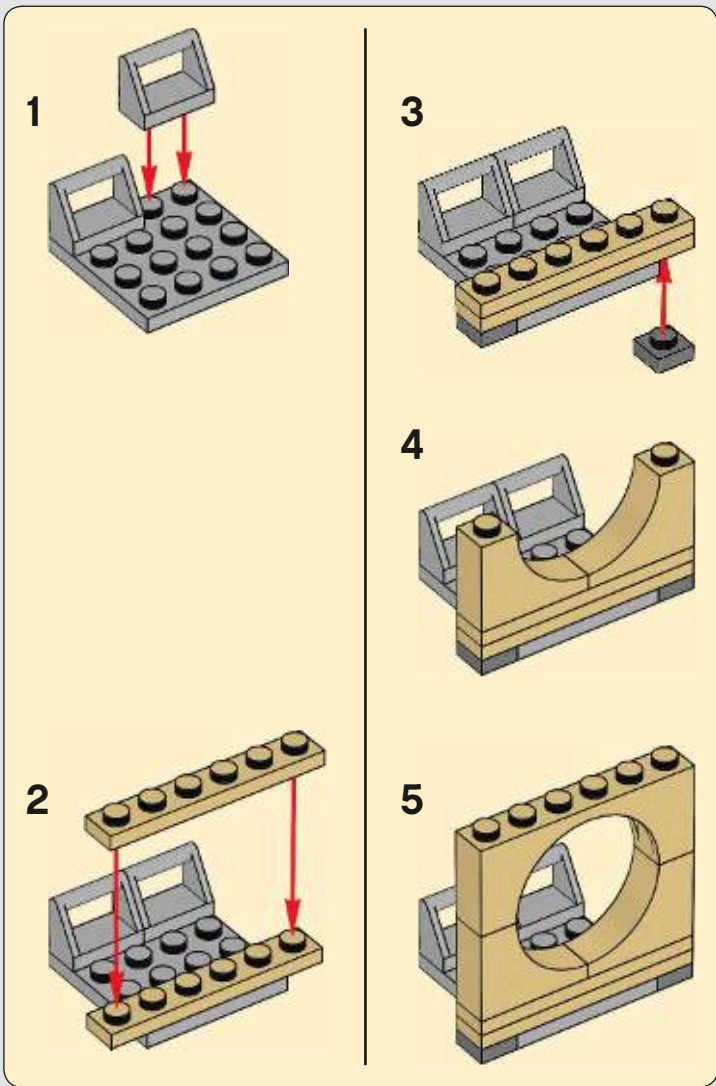

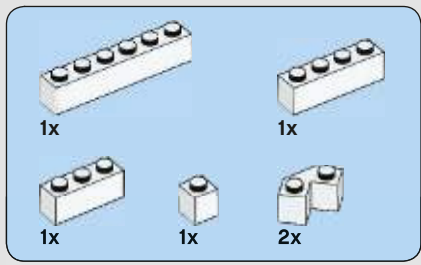

48

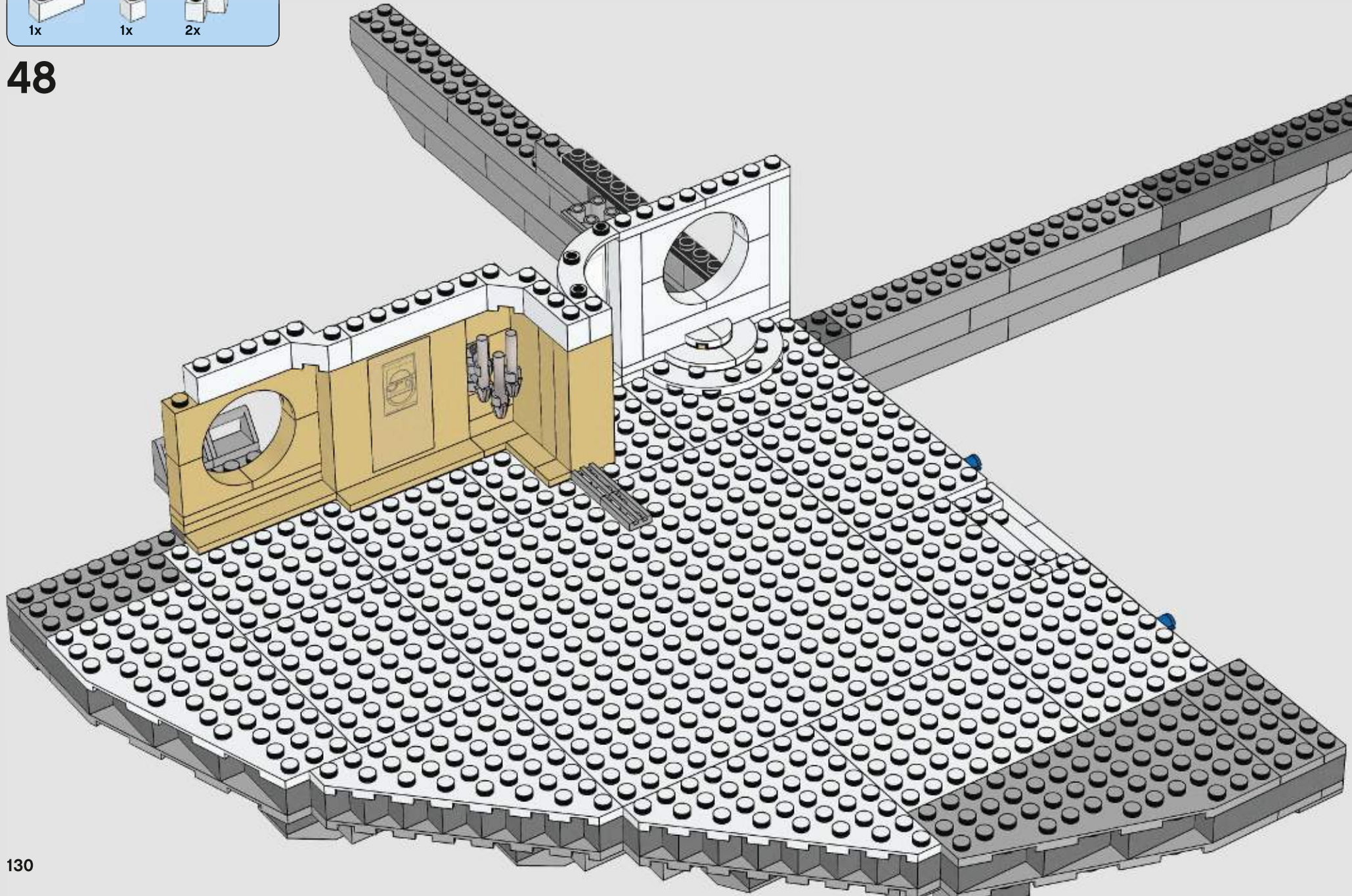

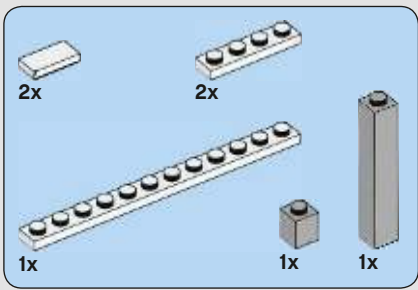

49

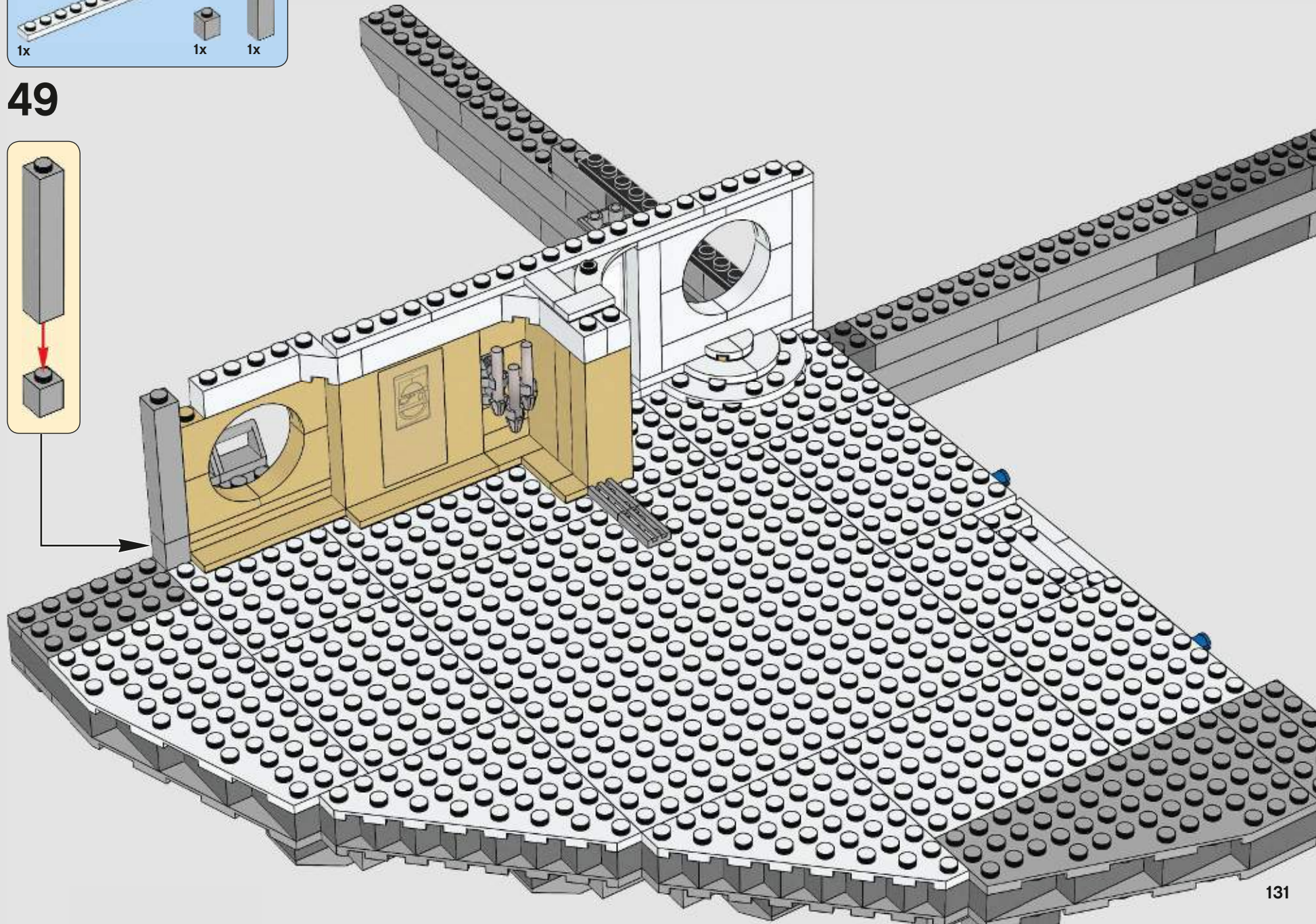
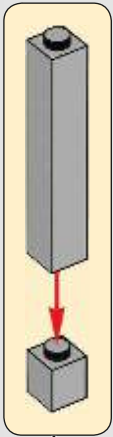

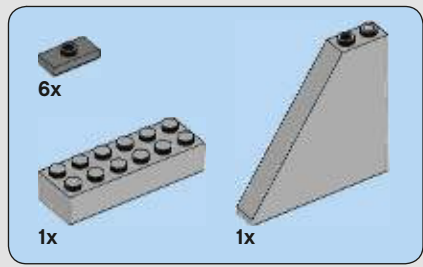

50

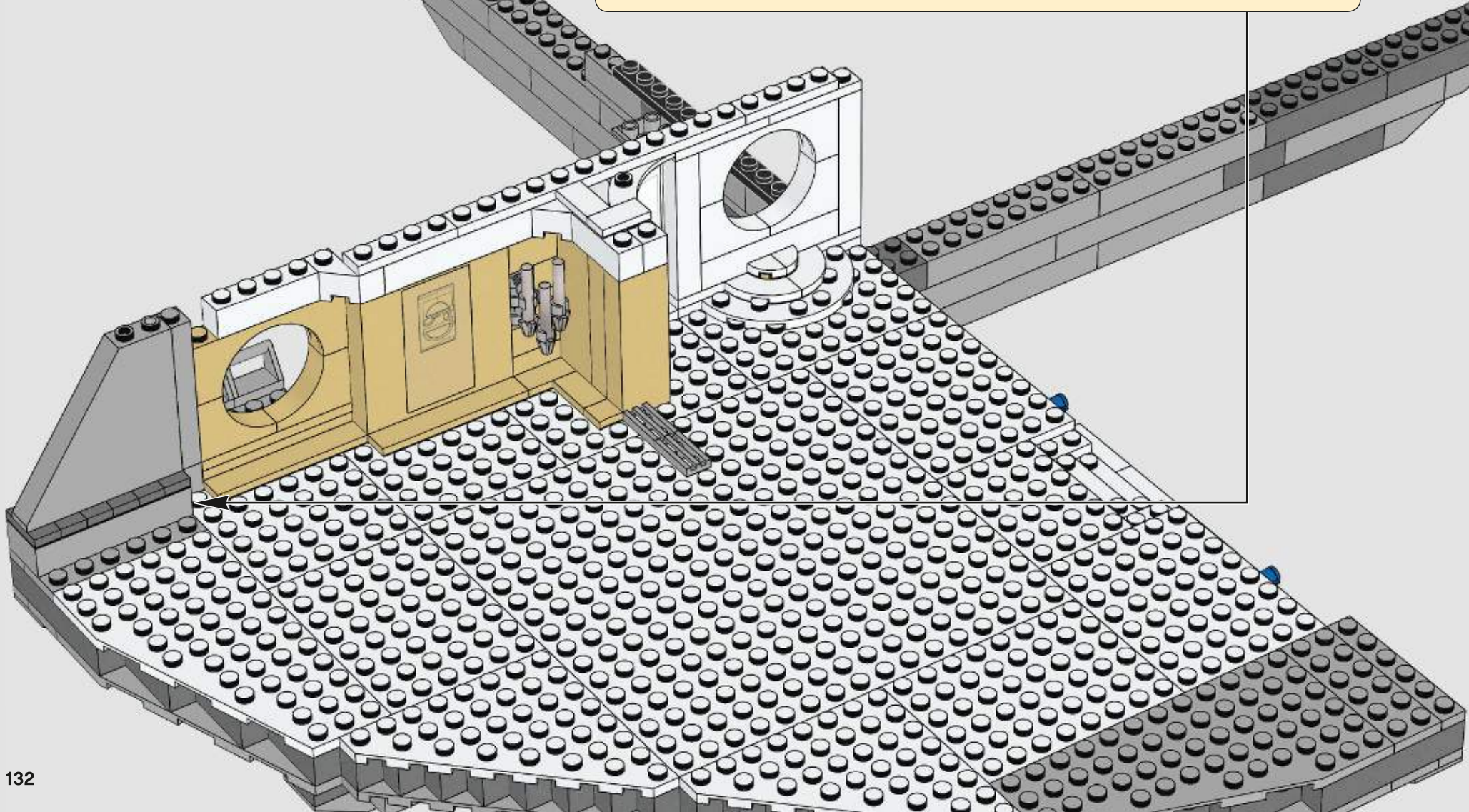
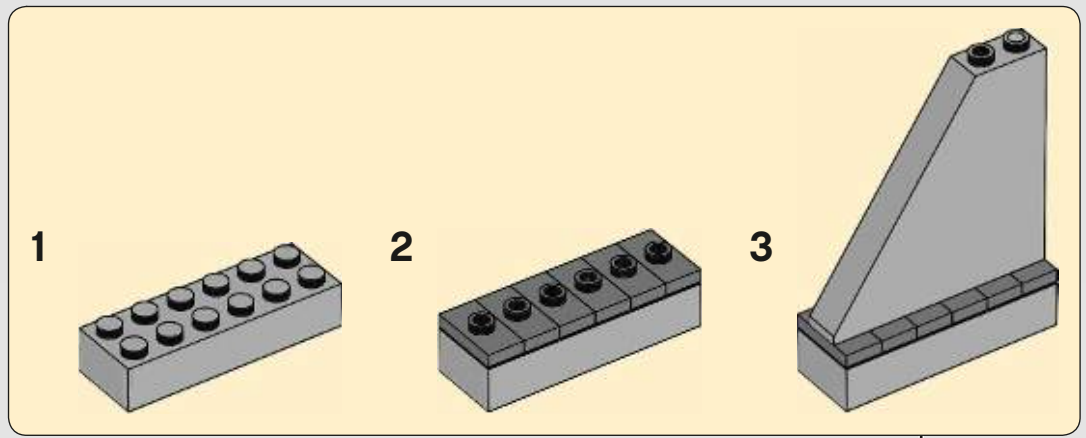

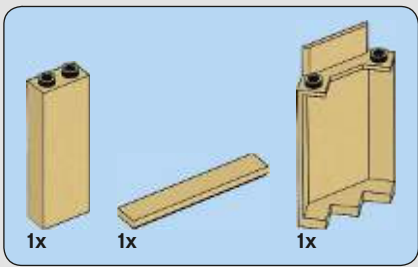

51

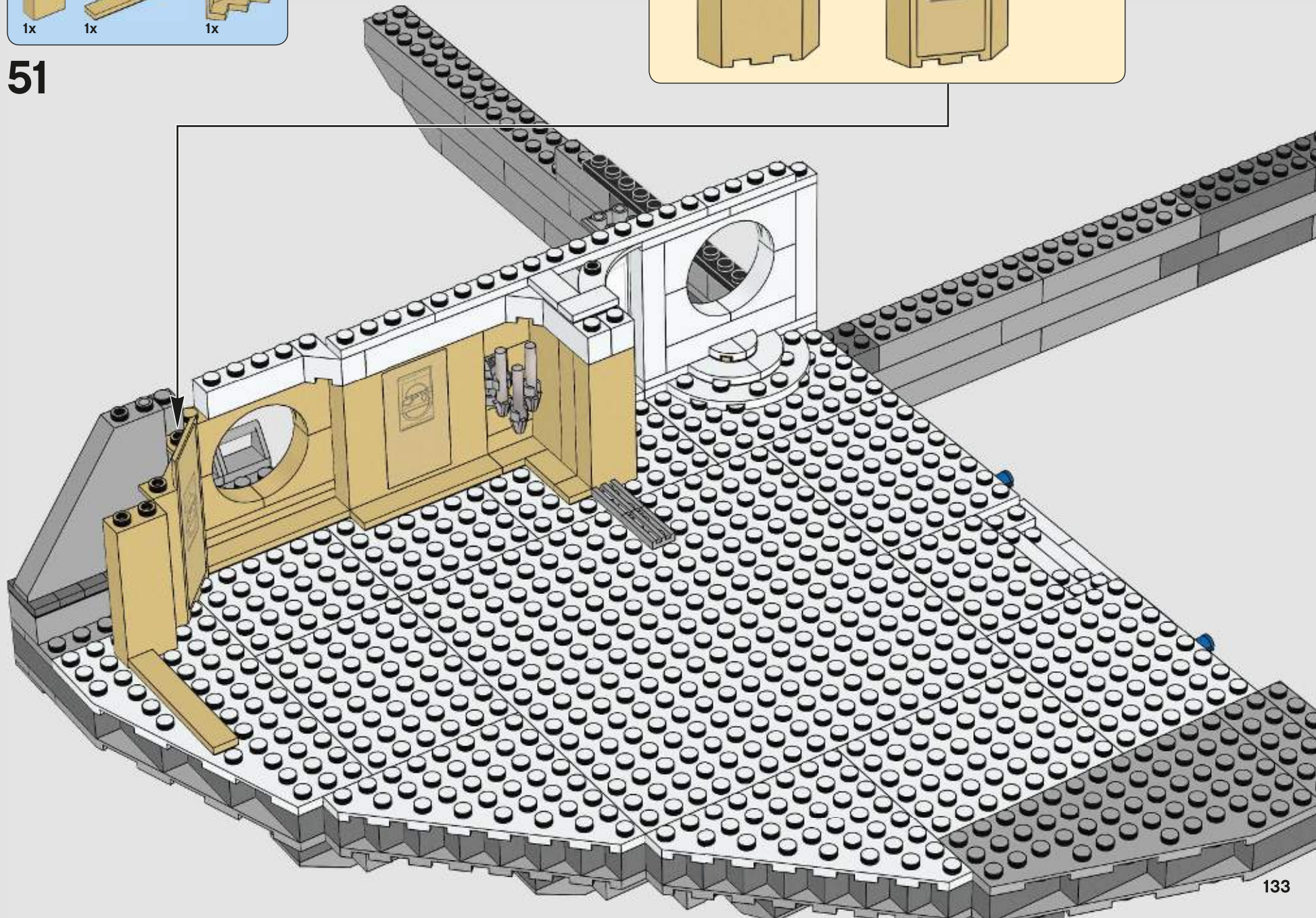
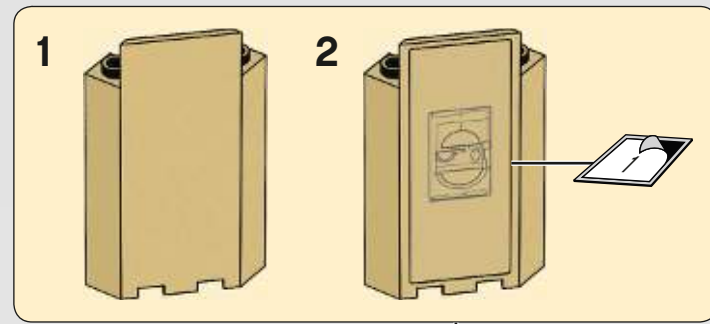



2x

52

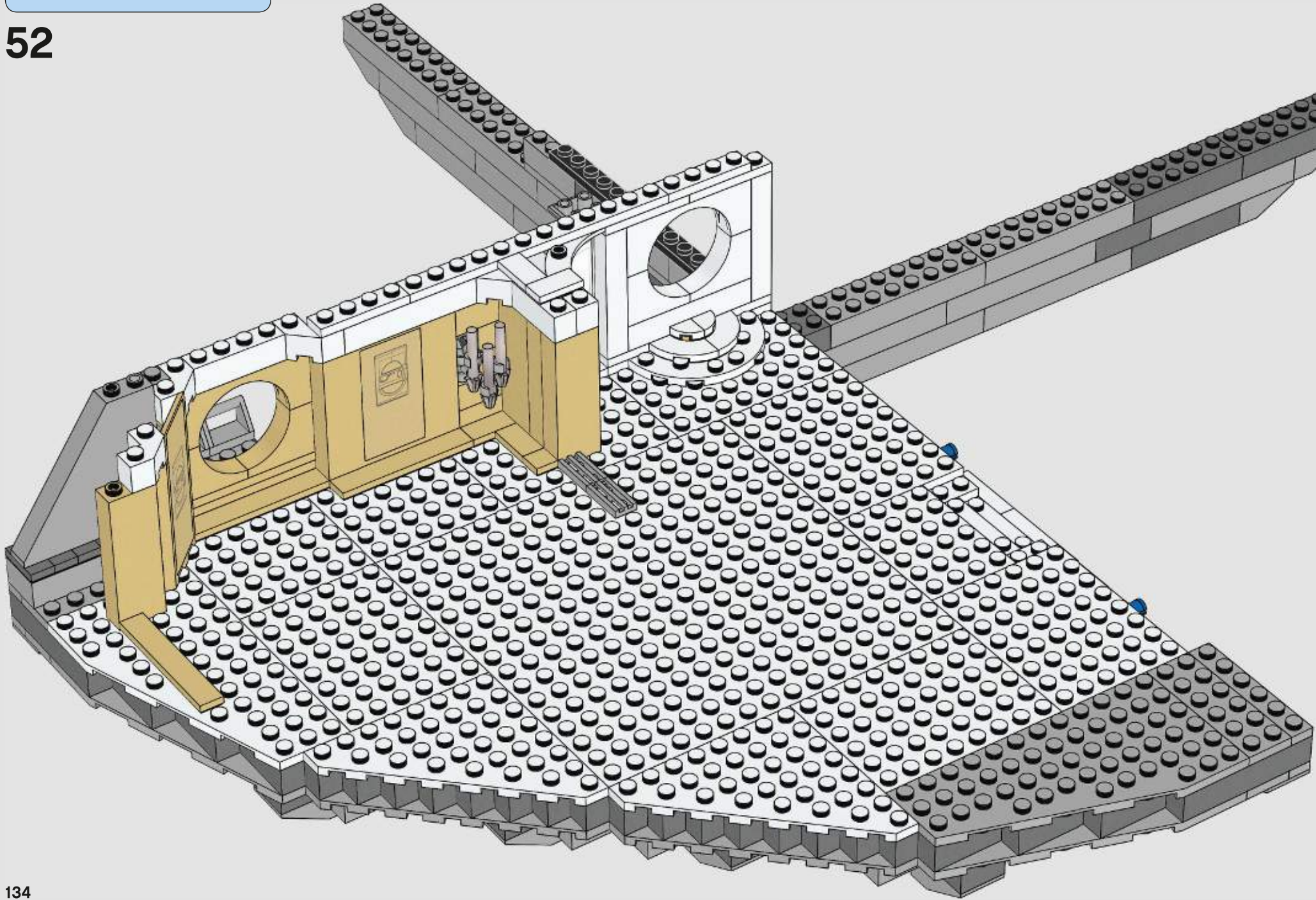



53

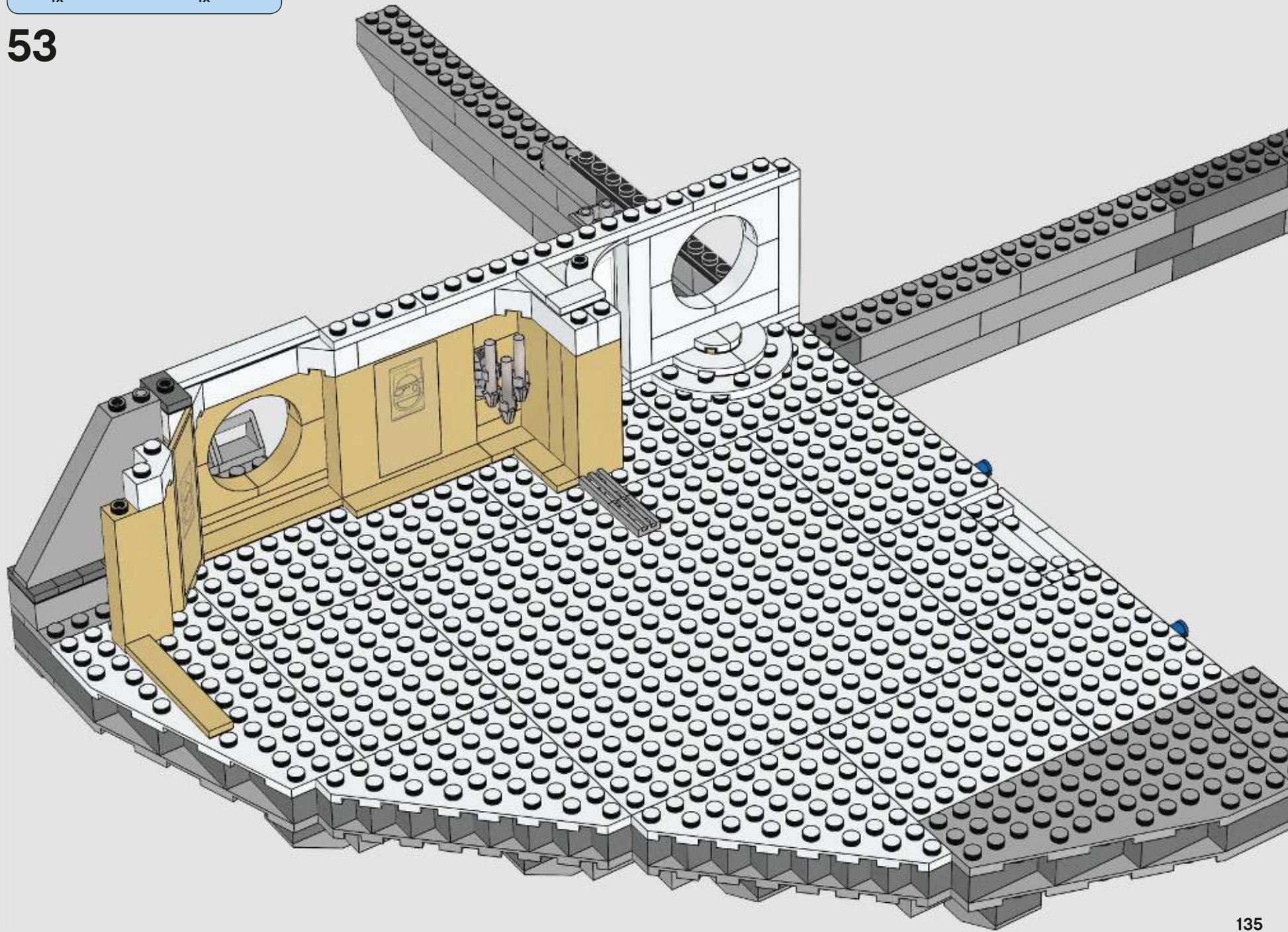

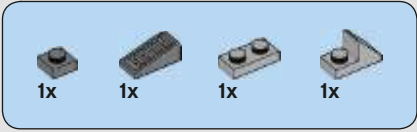

54

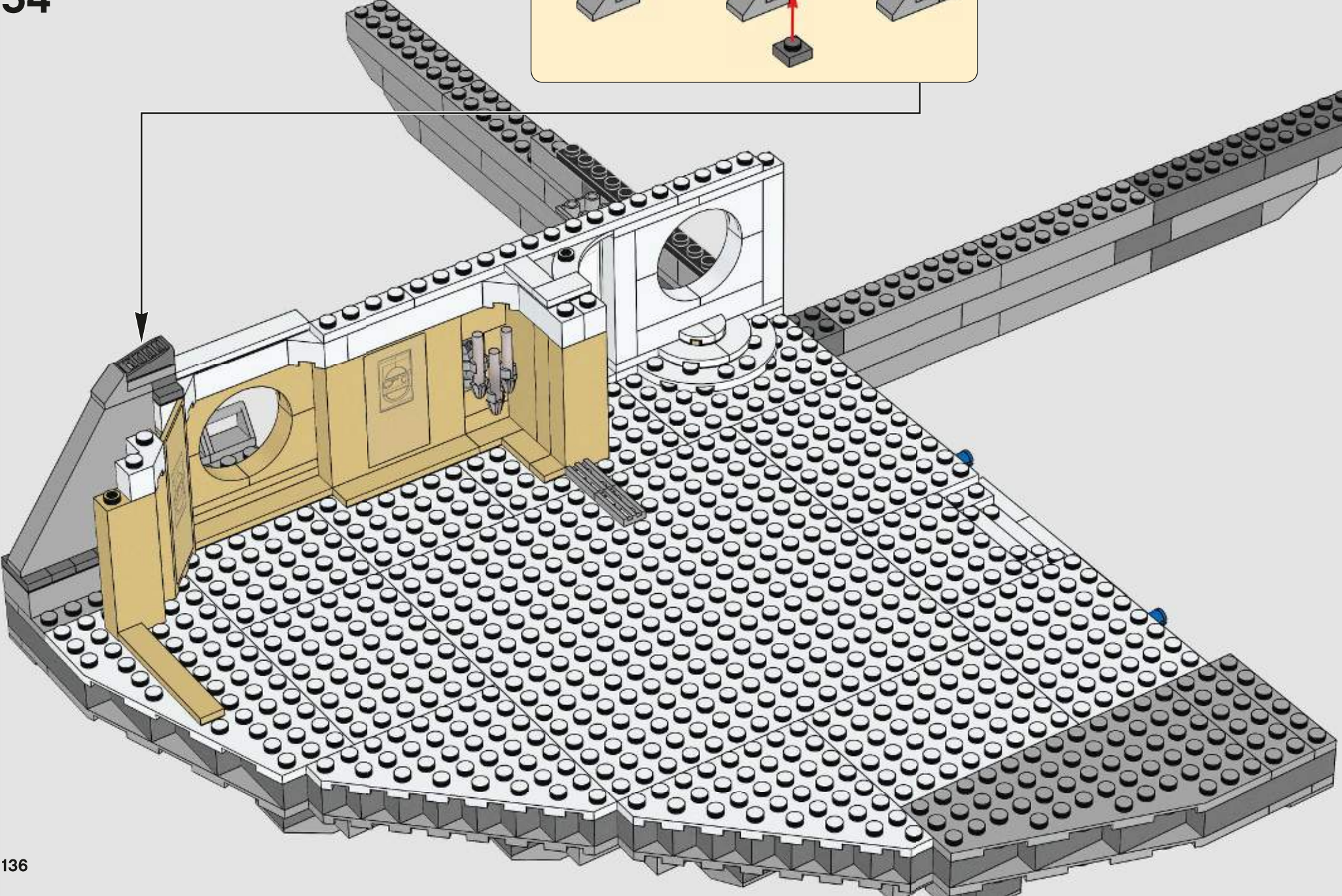
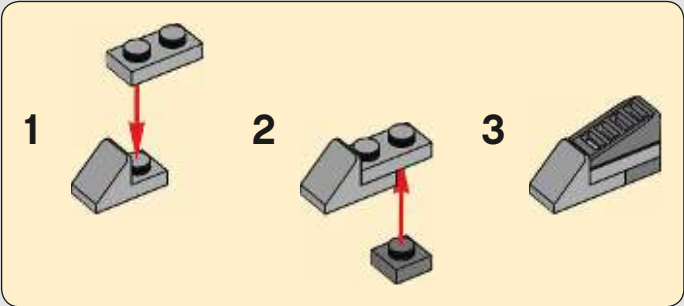

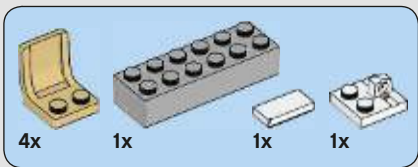

55

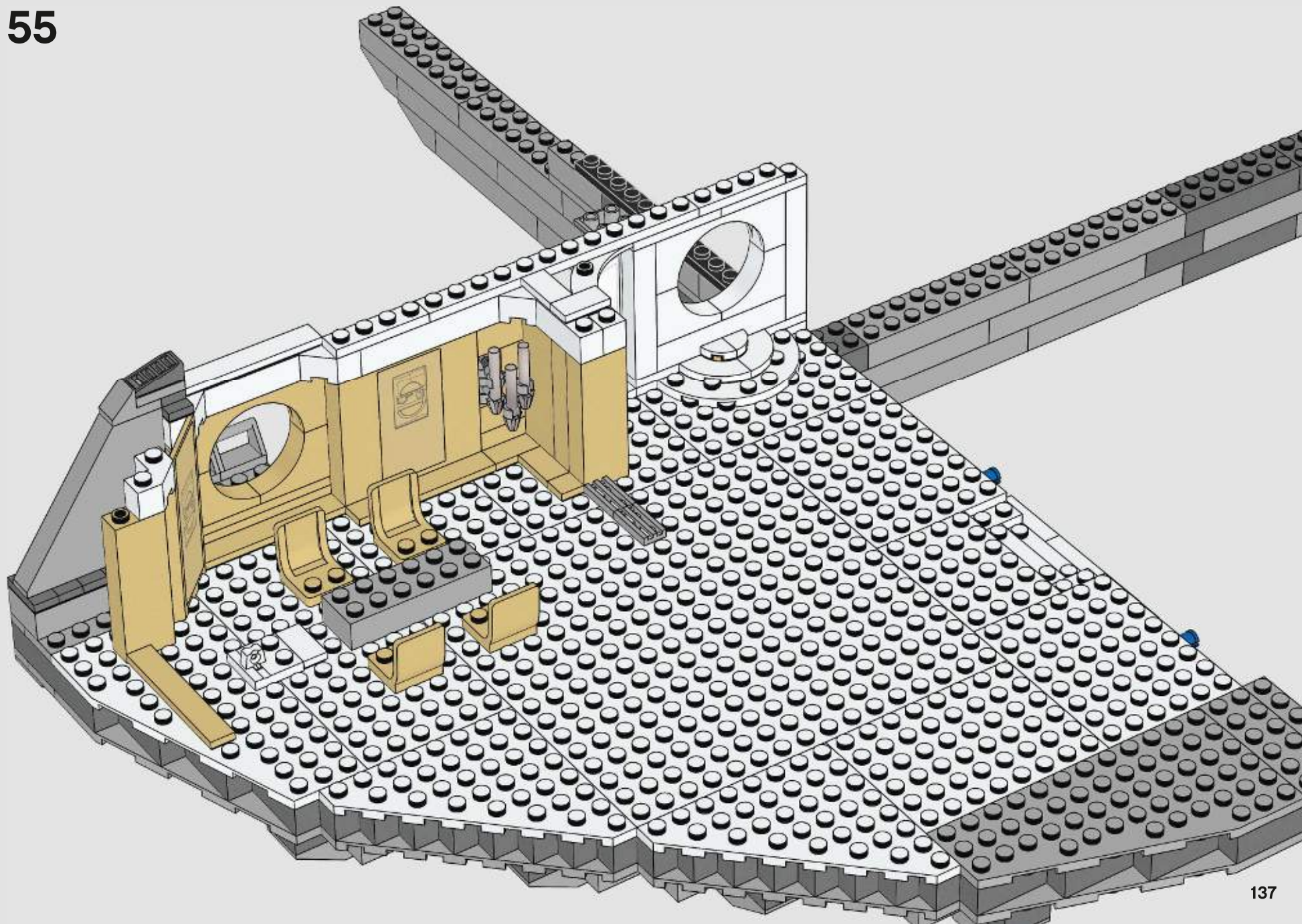

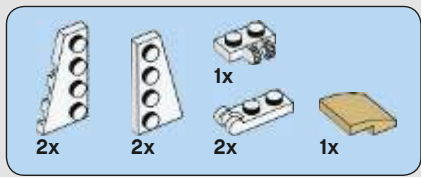

56

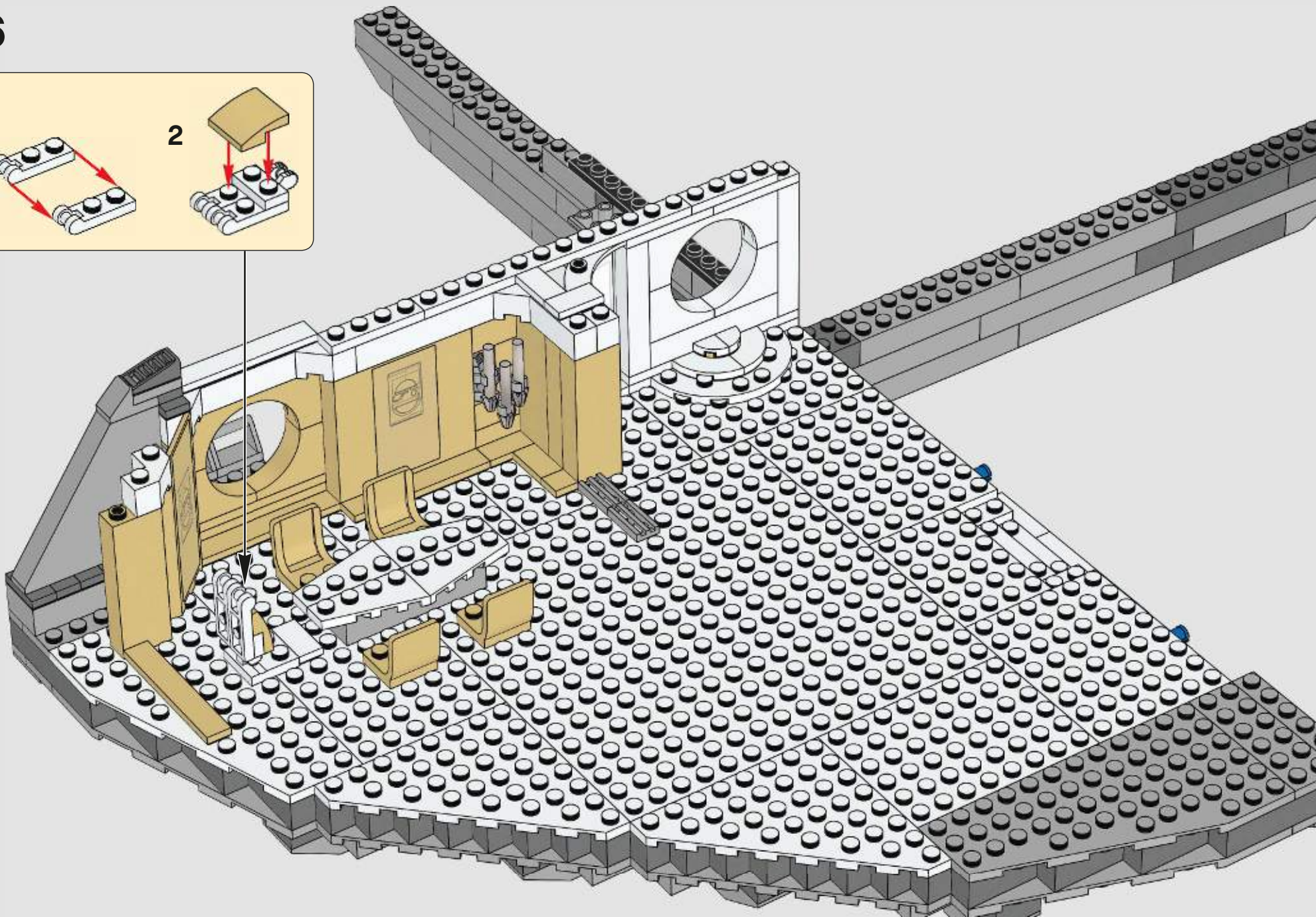
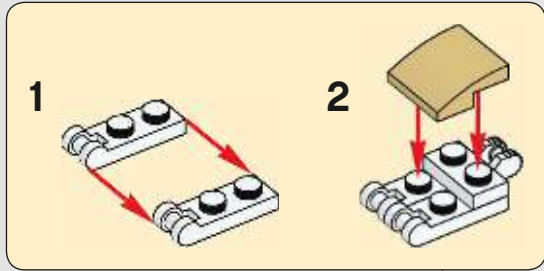

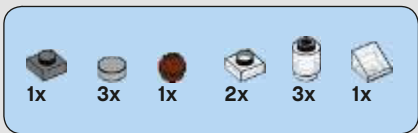

57

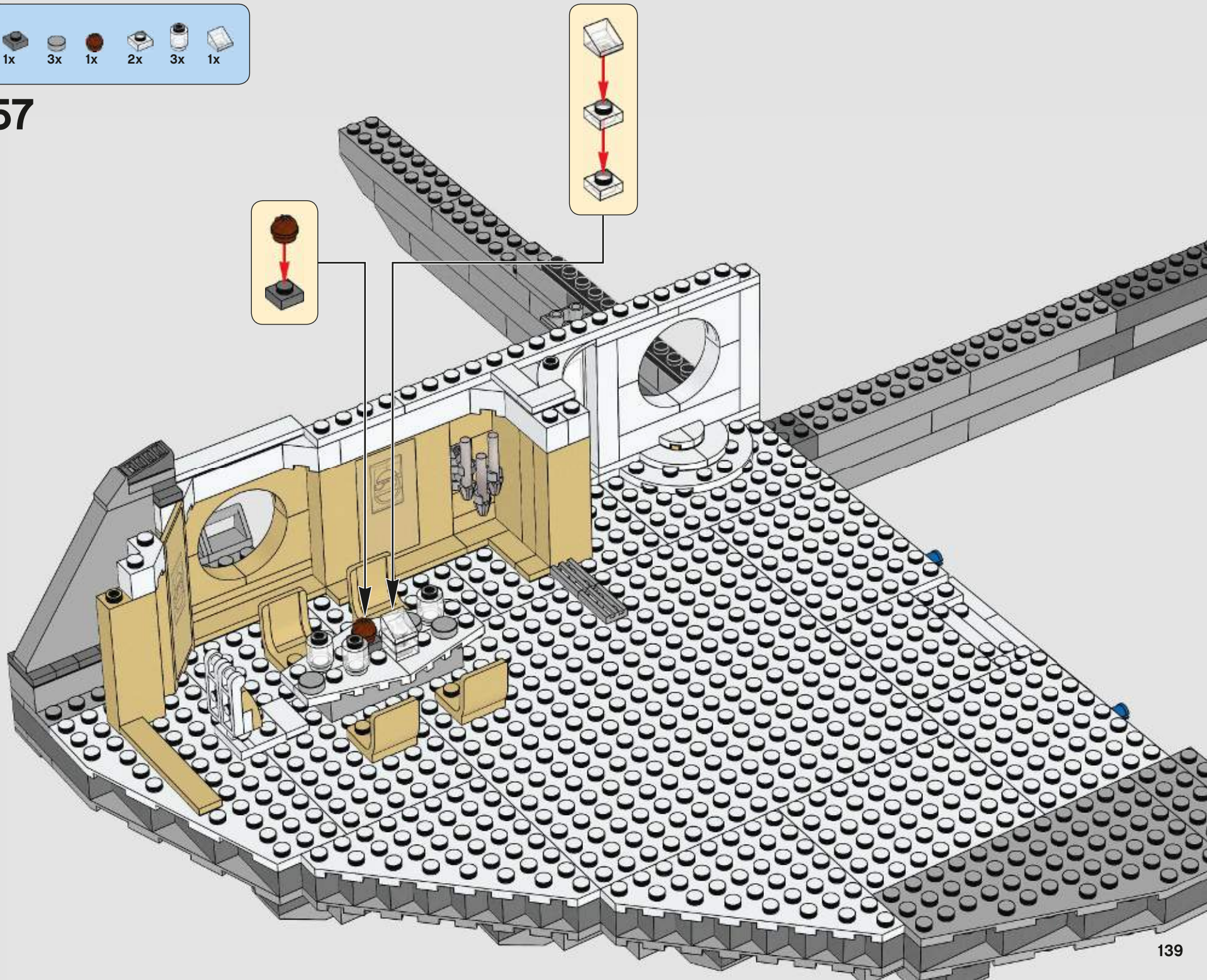

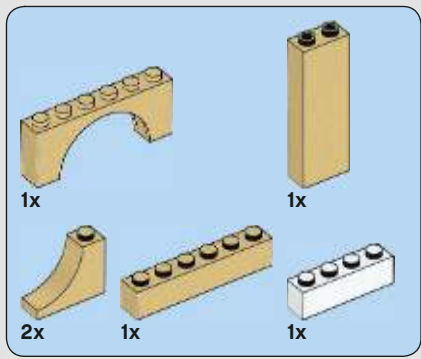

58

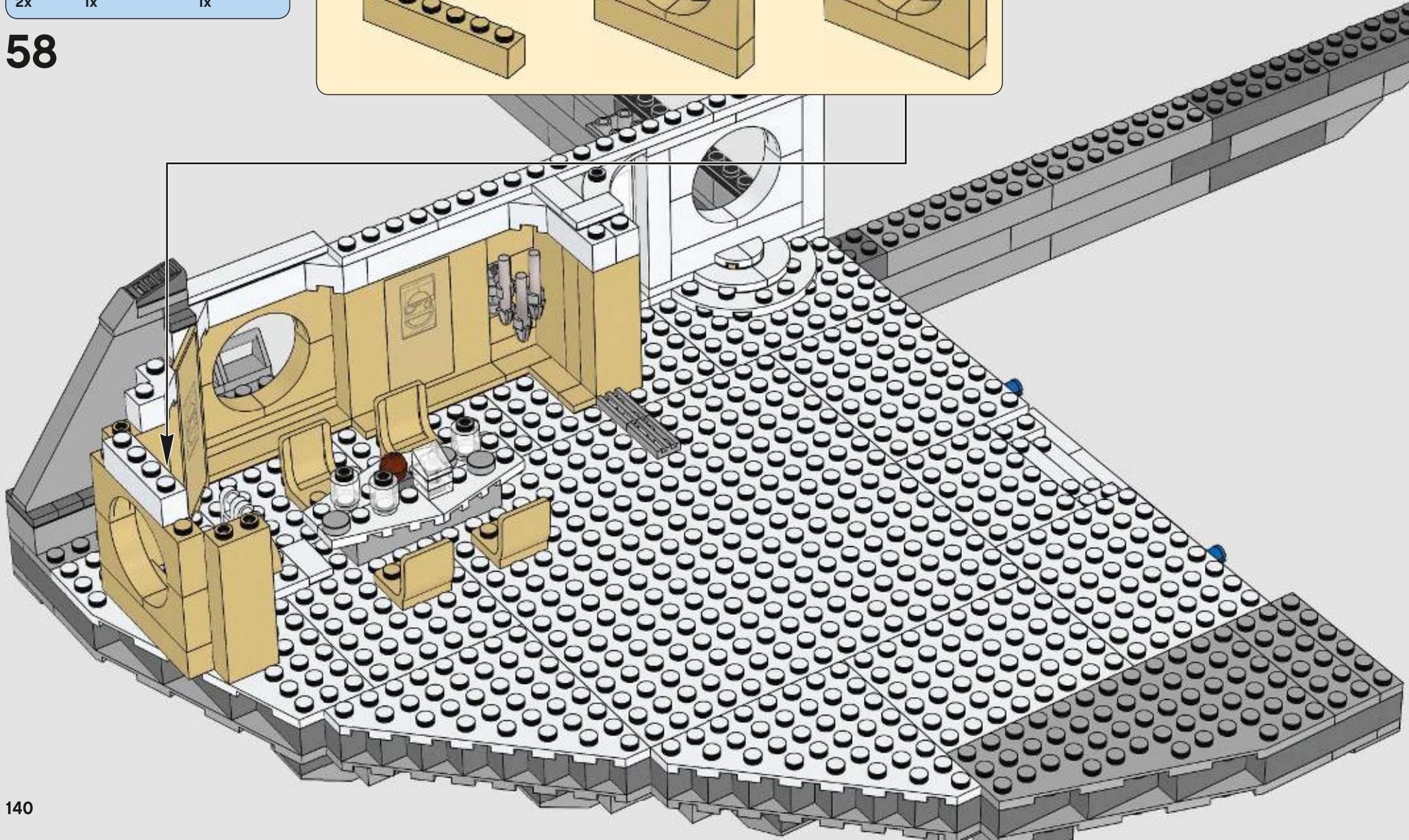
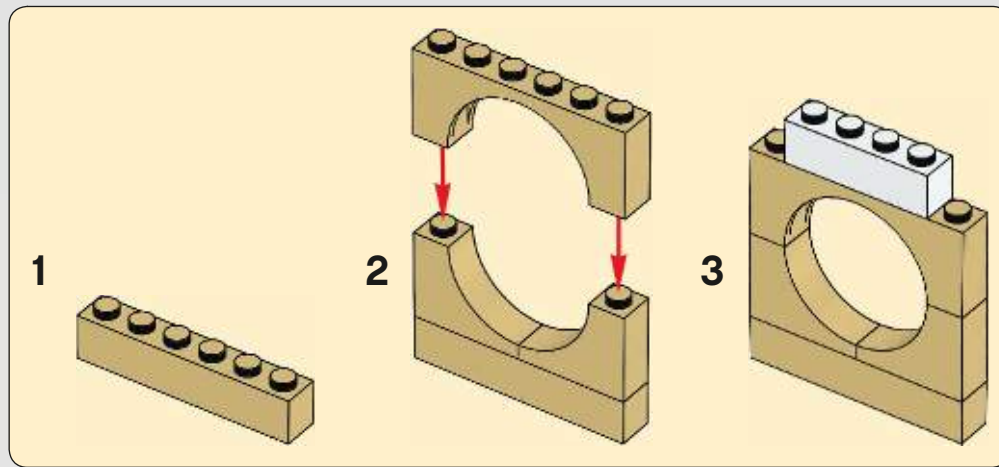

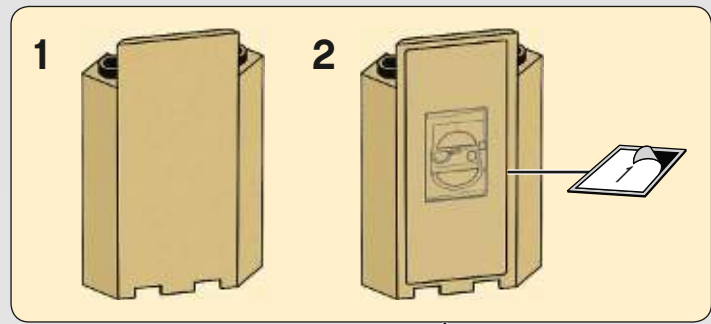
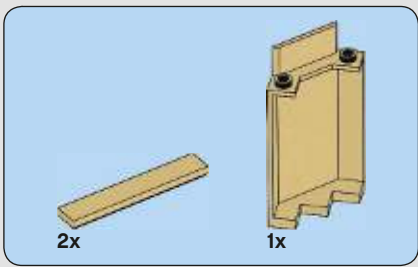

59

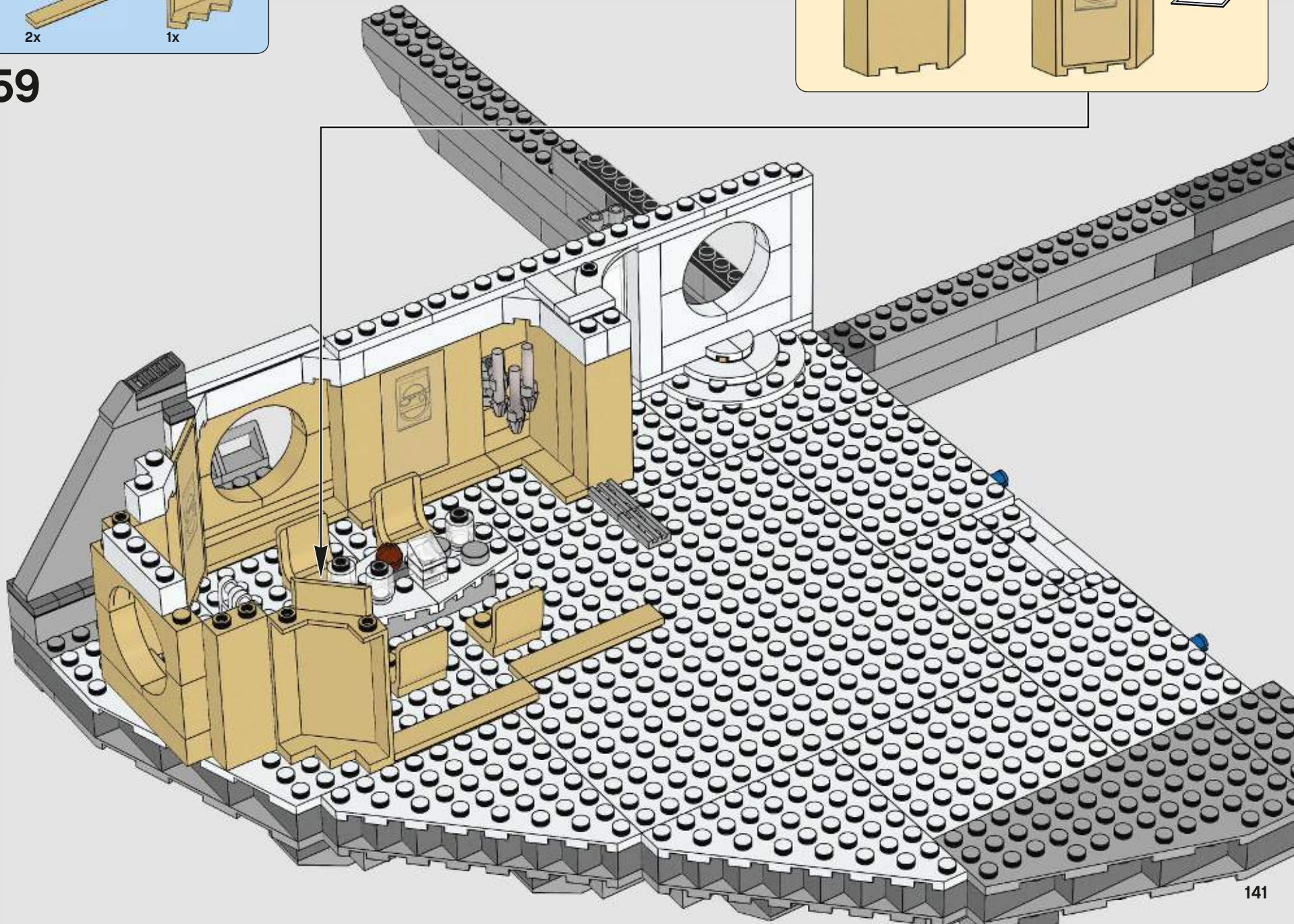

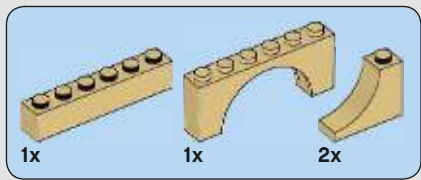

60

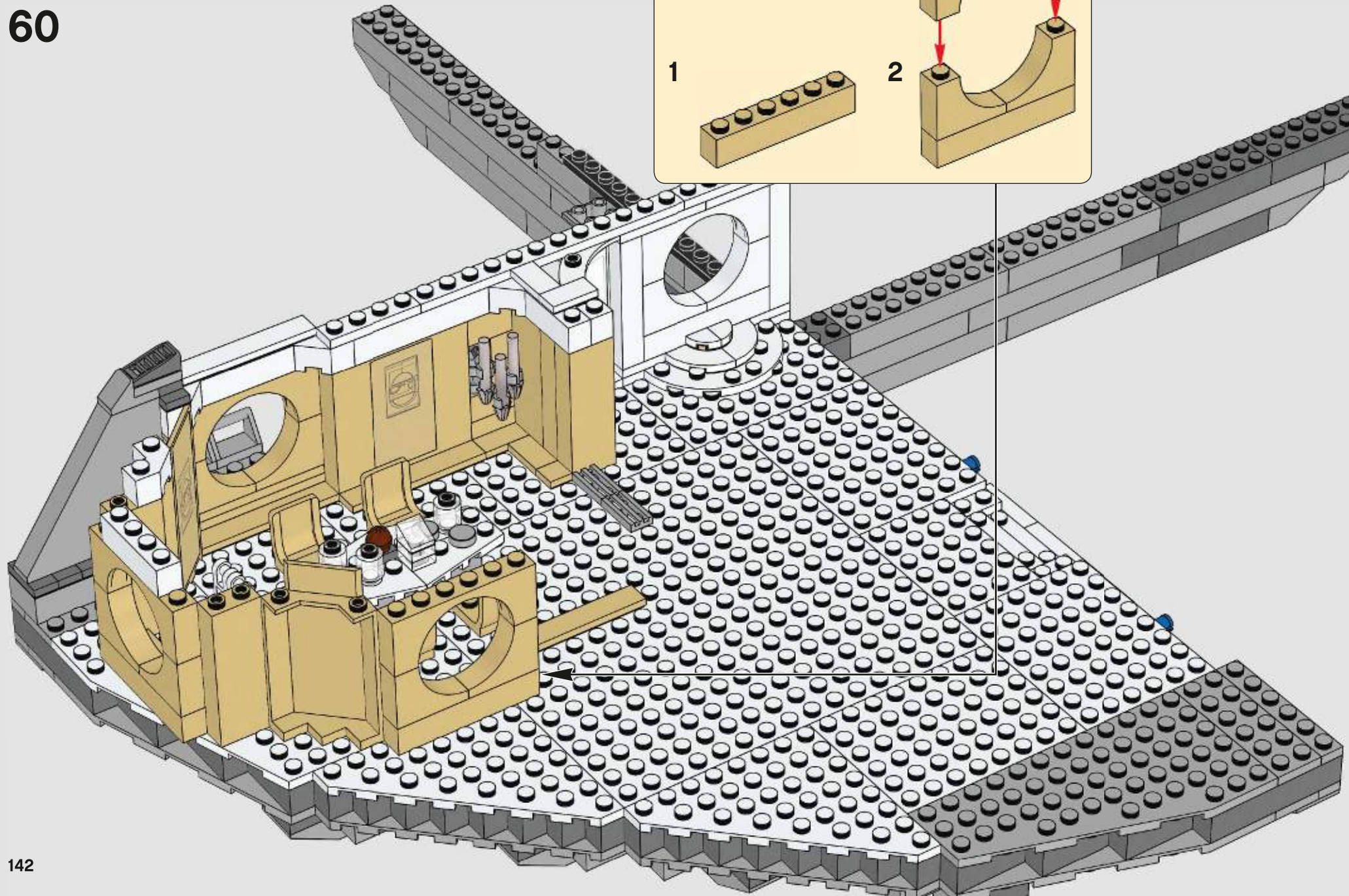
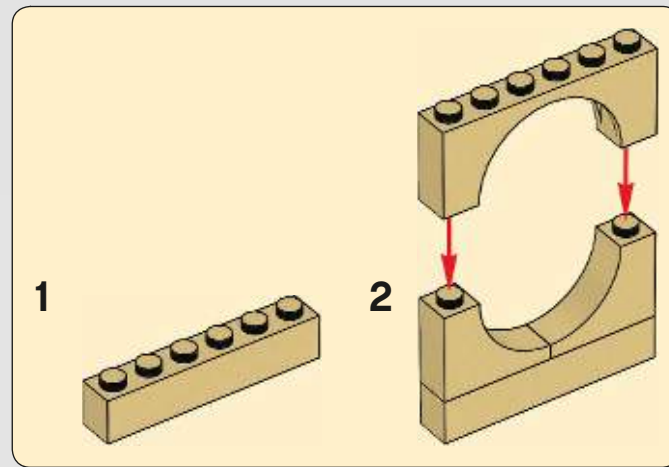

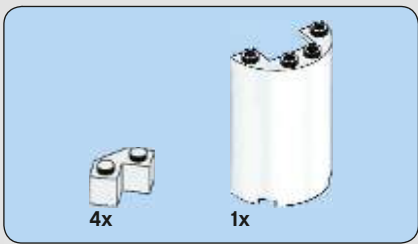

61

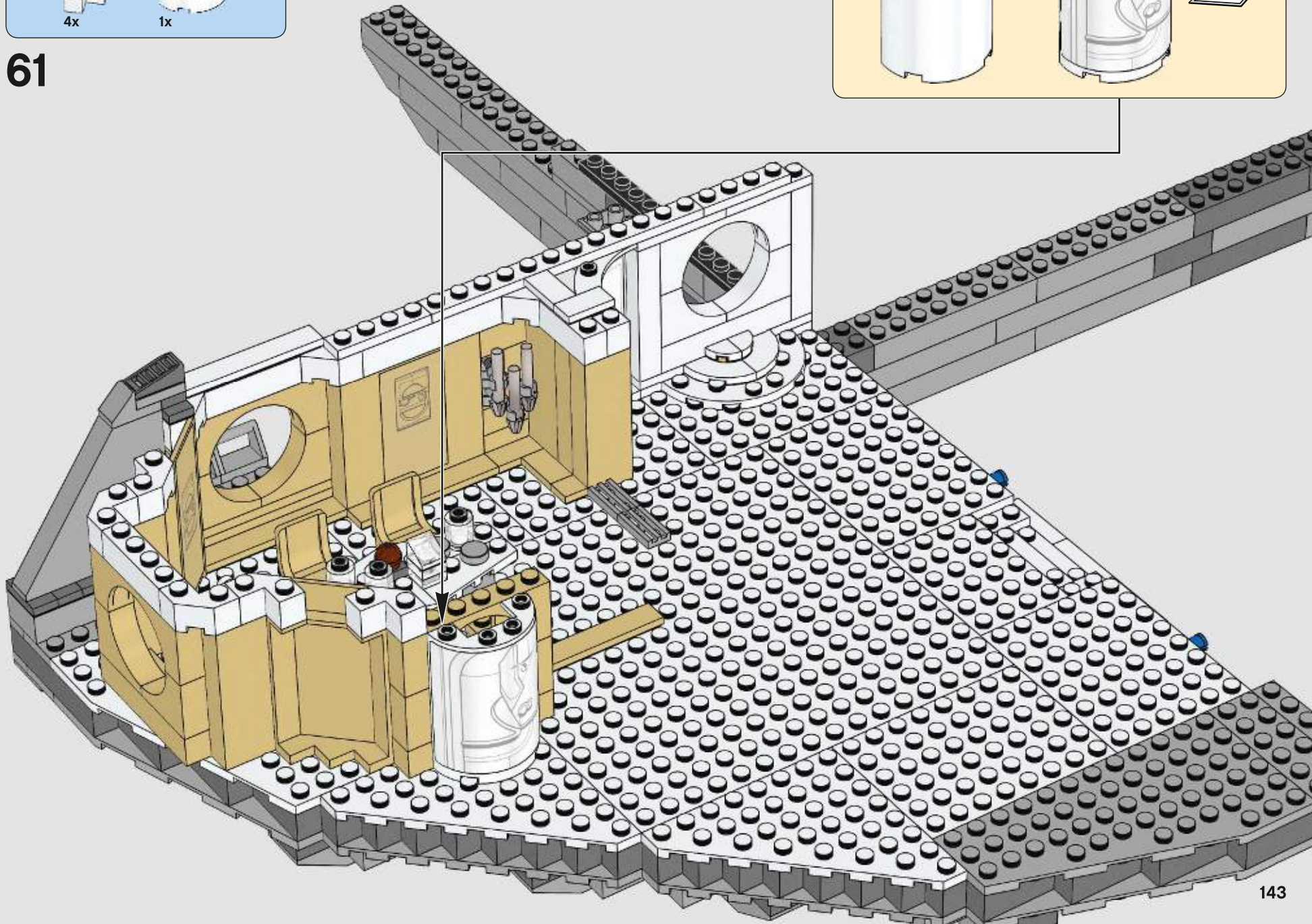
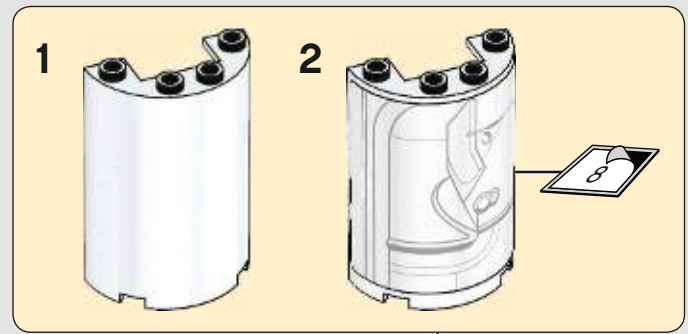

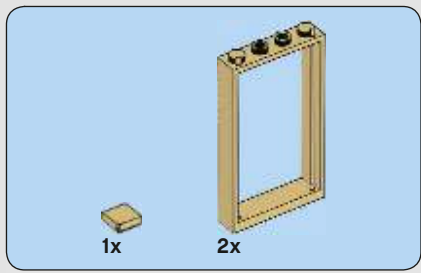

62

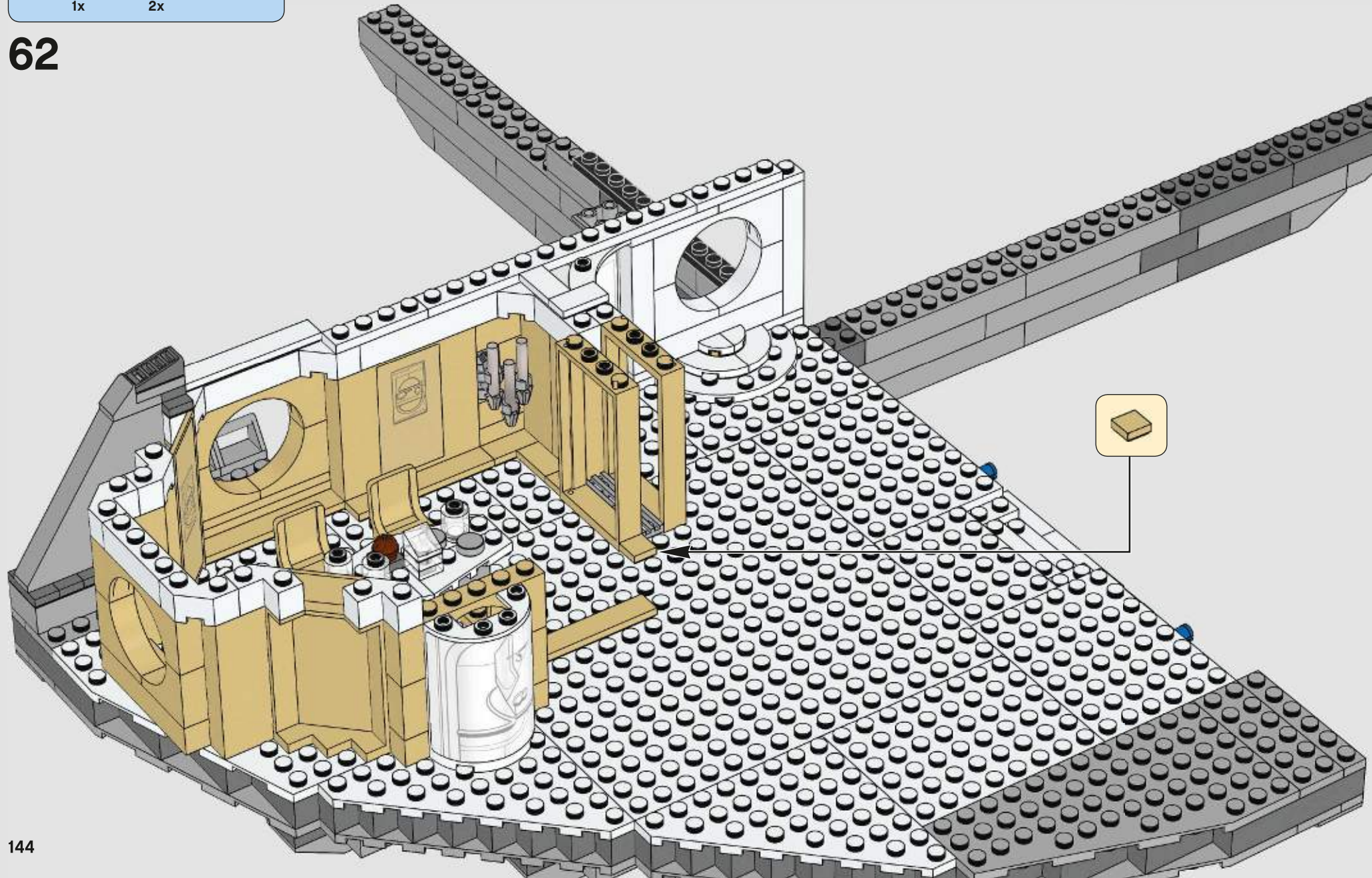

1x 5x

63

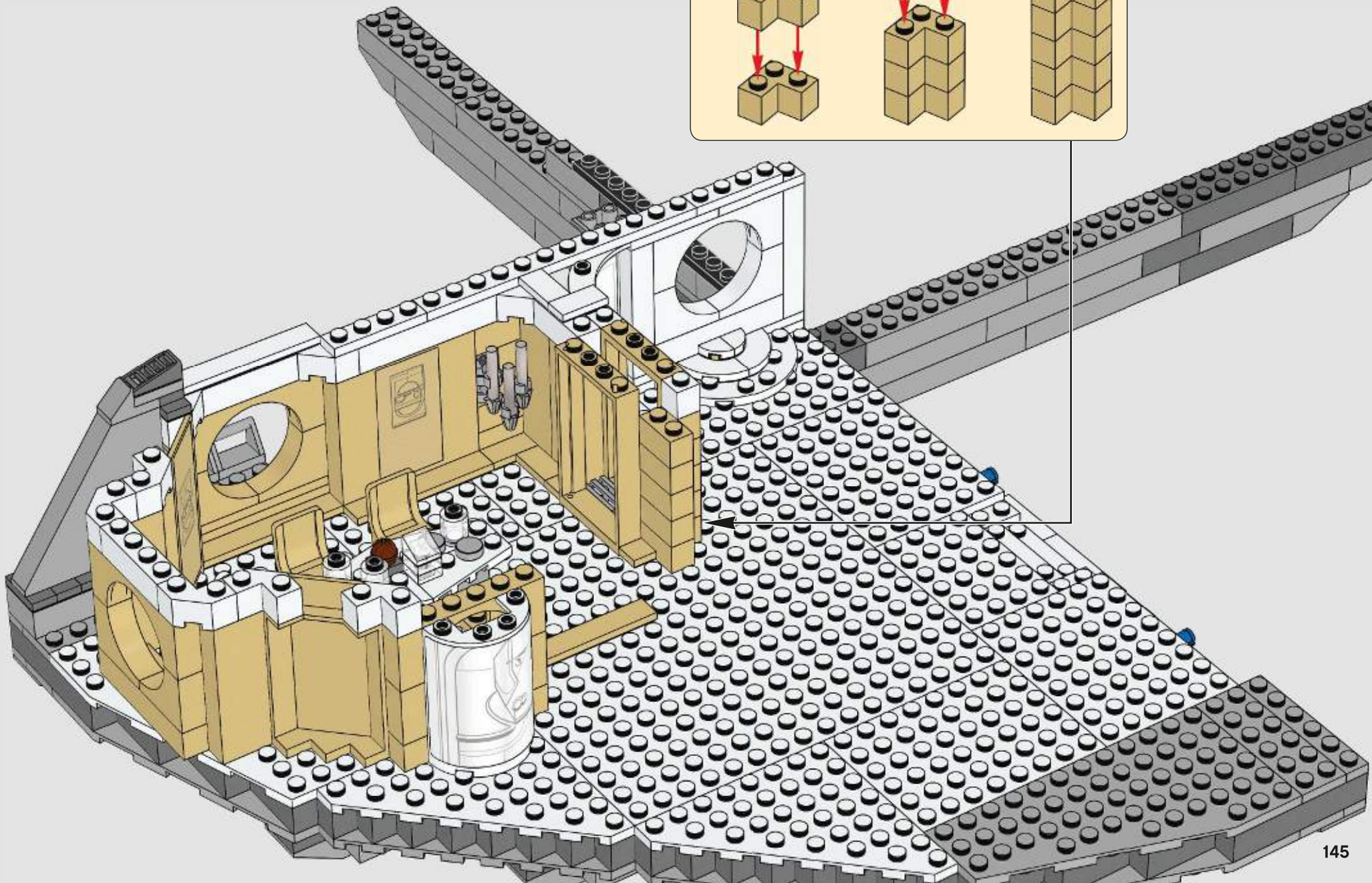
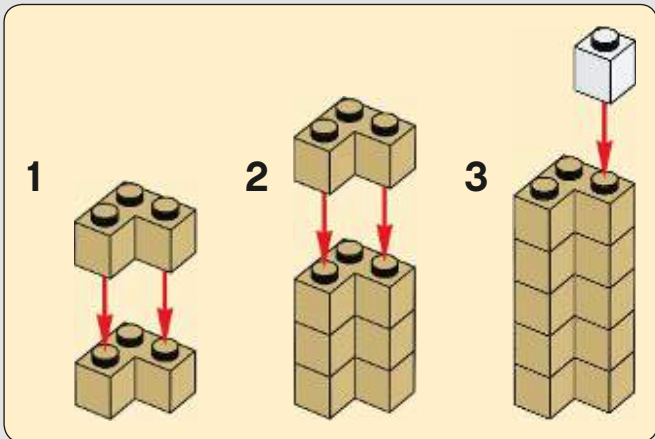



64

1

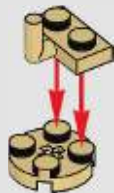

2

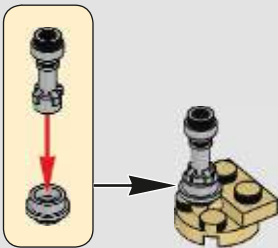

3

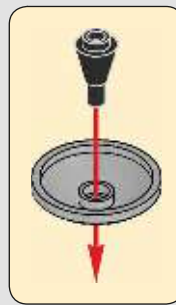

4

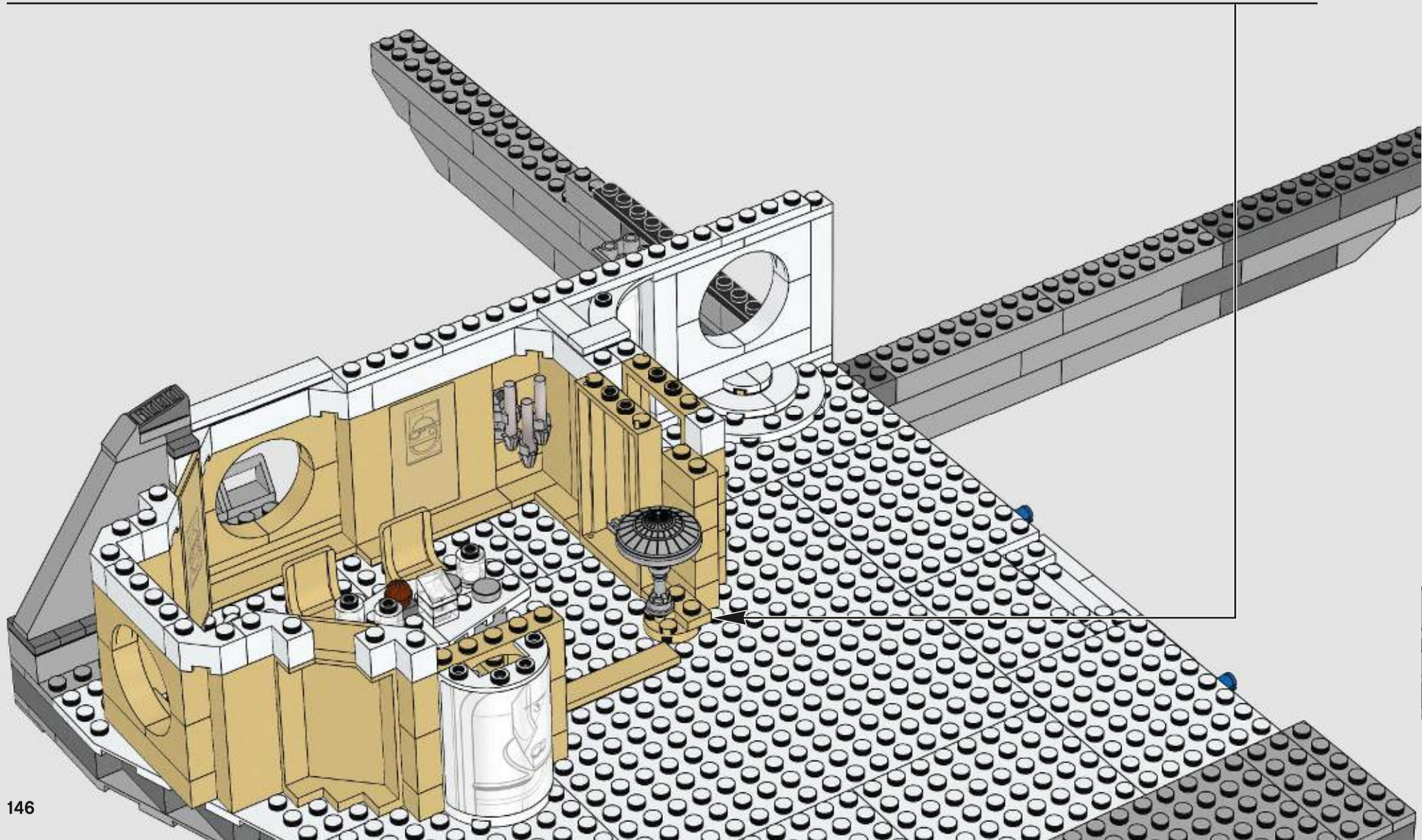

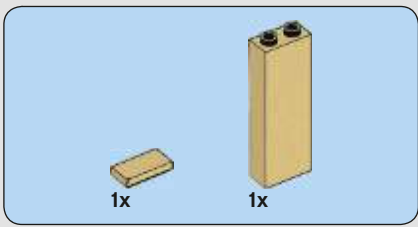

65

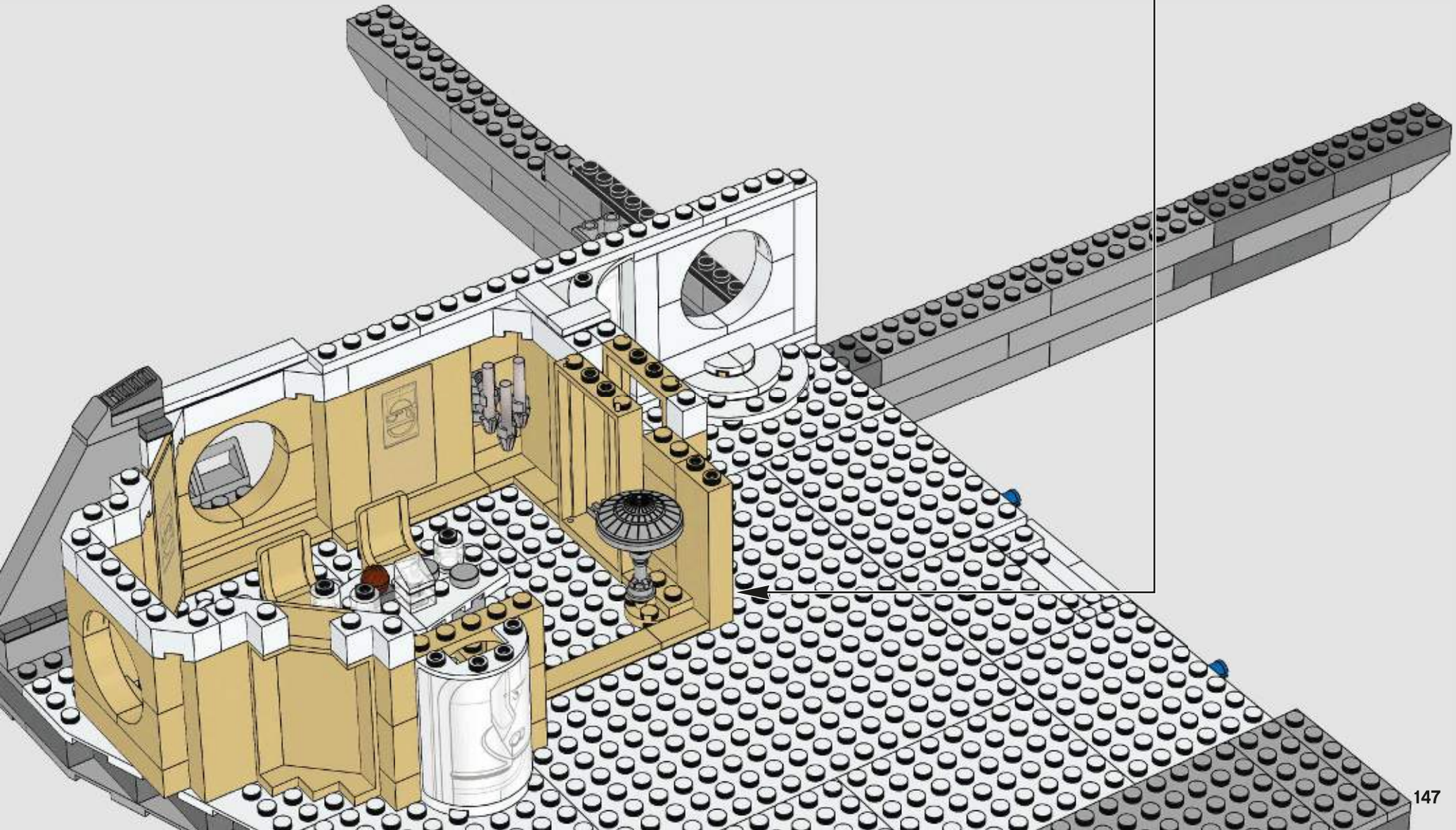
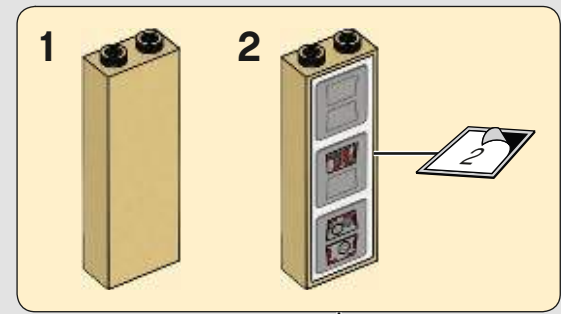

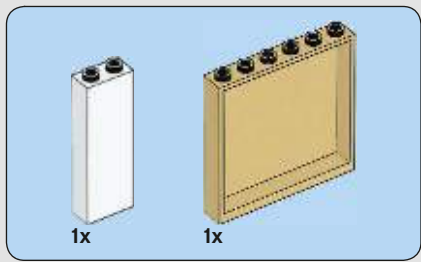

66

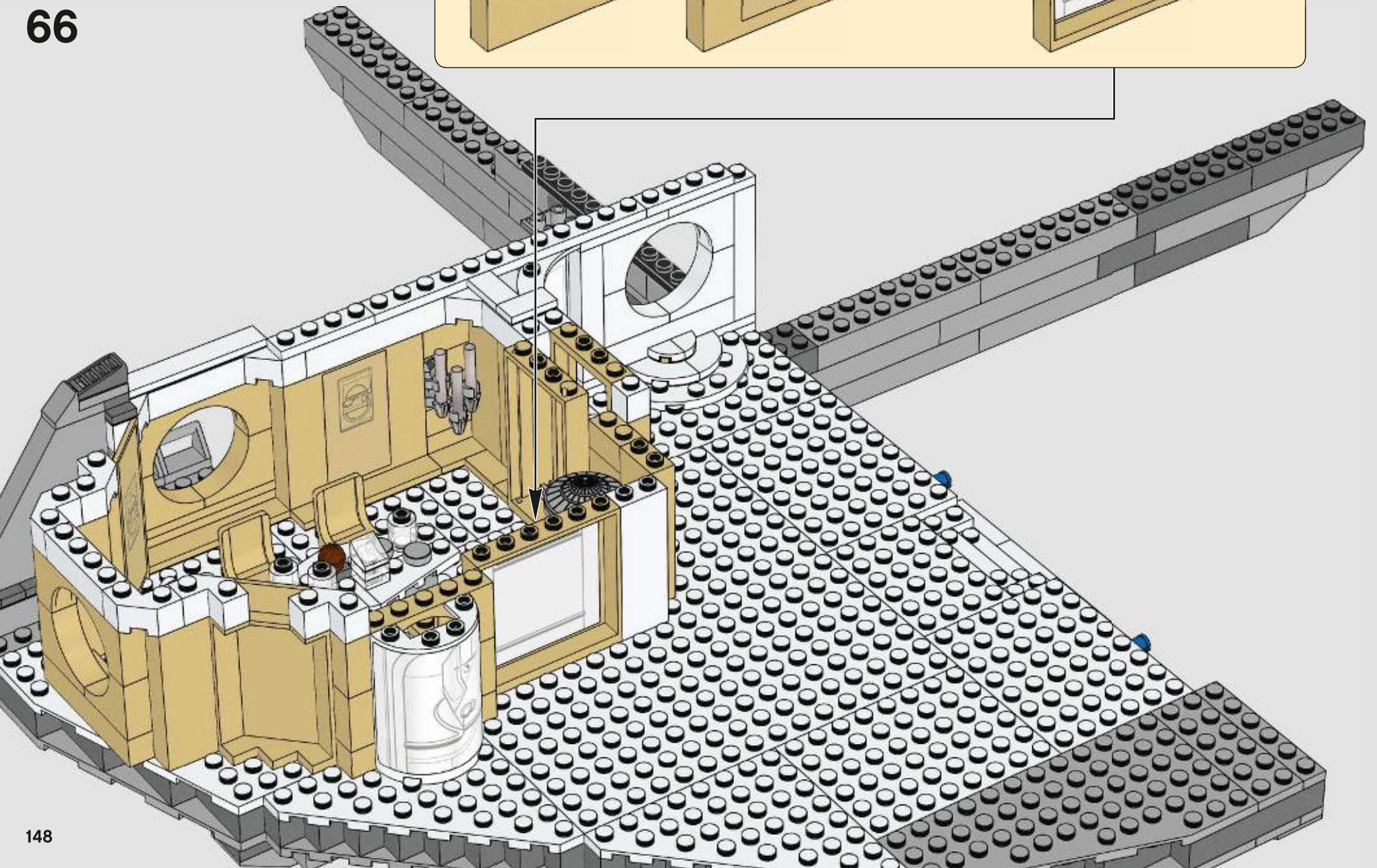
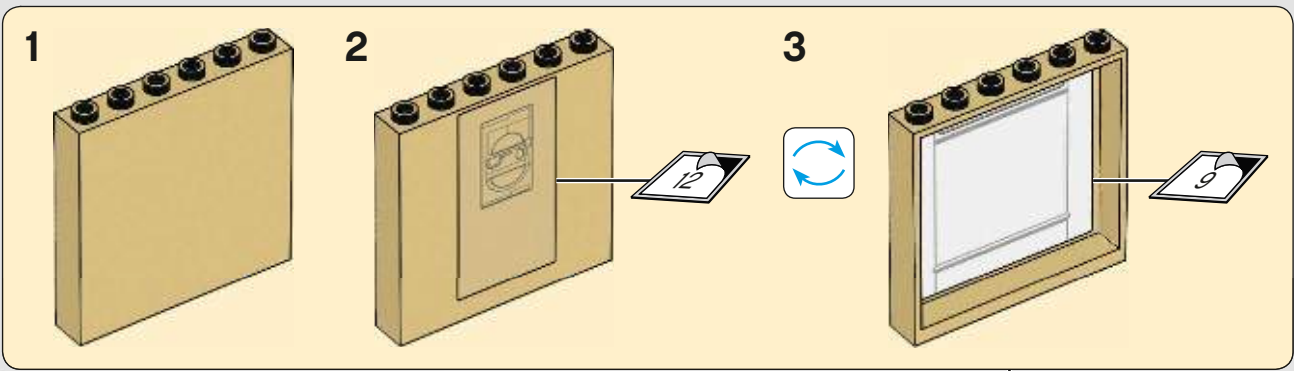

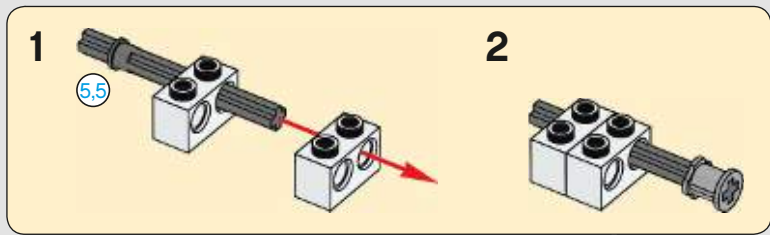
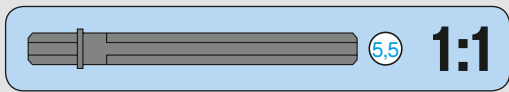
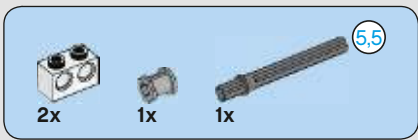

67

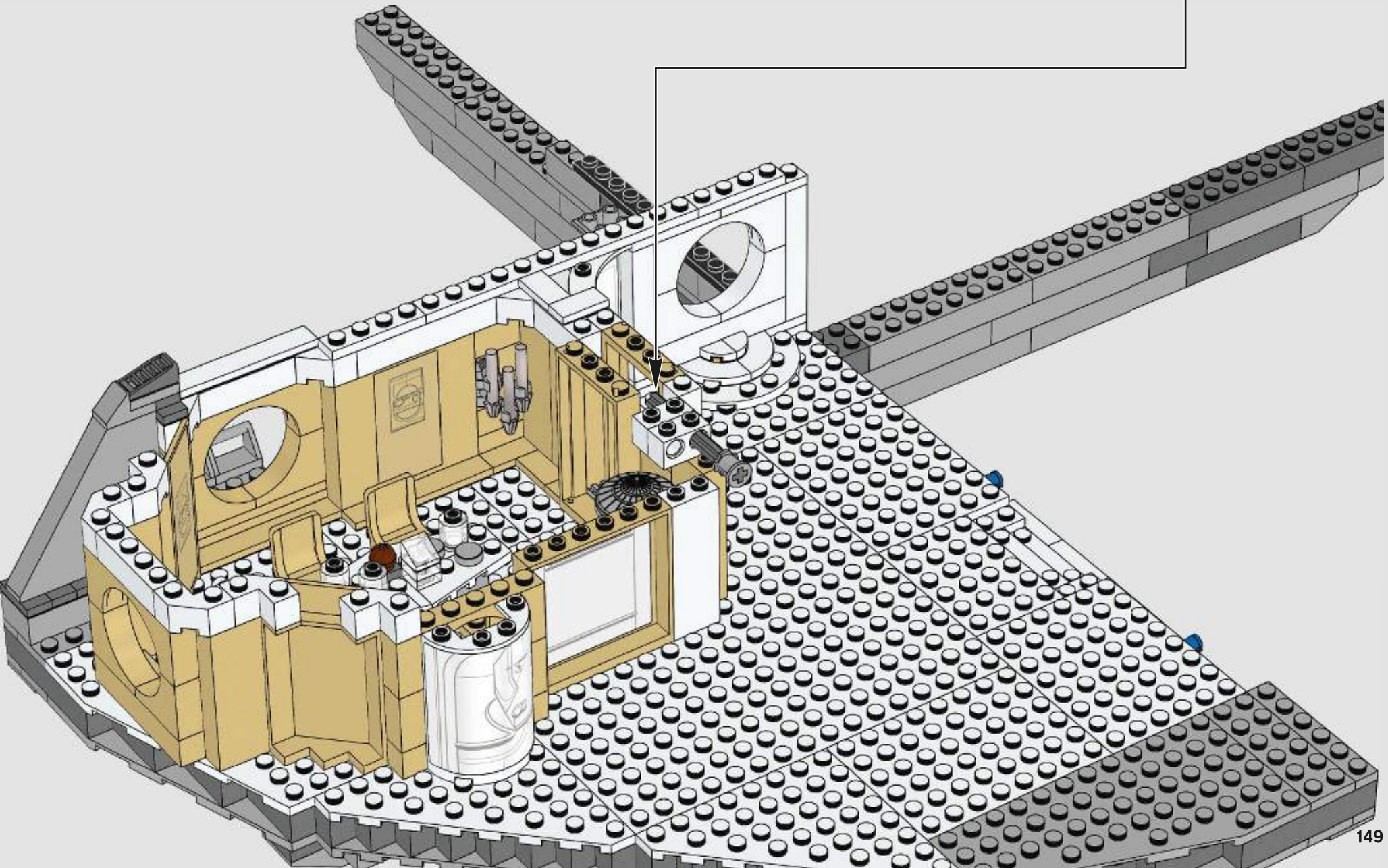

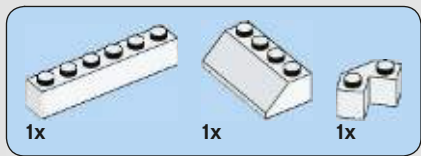

68

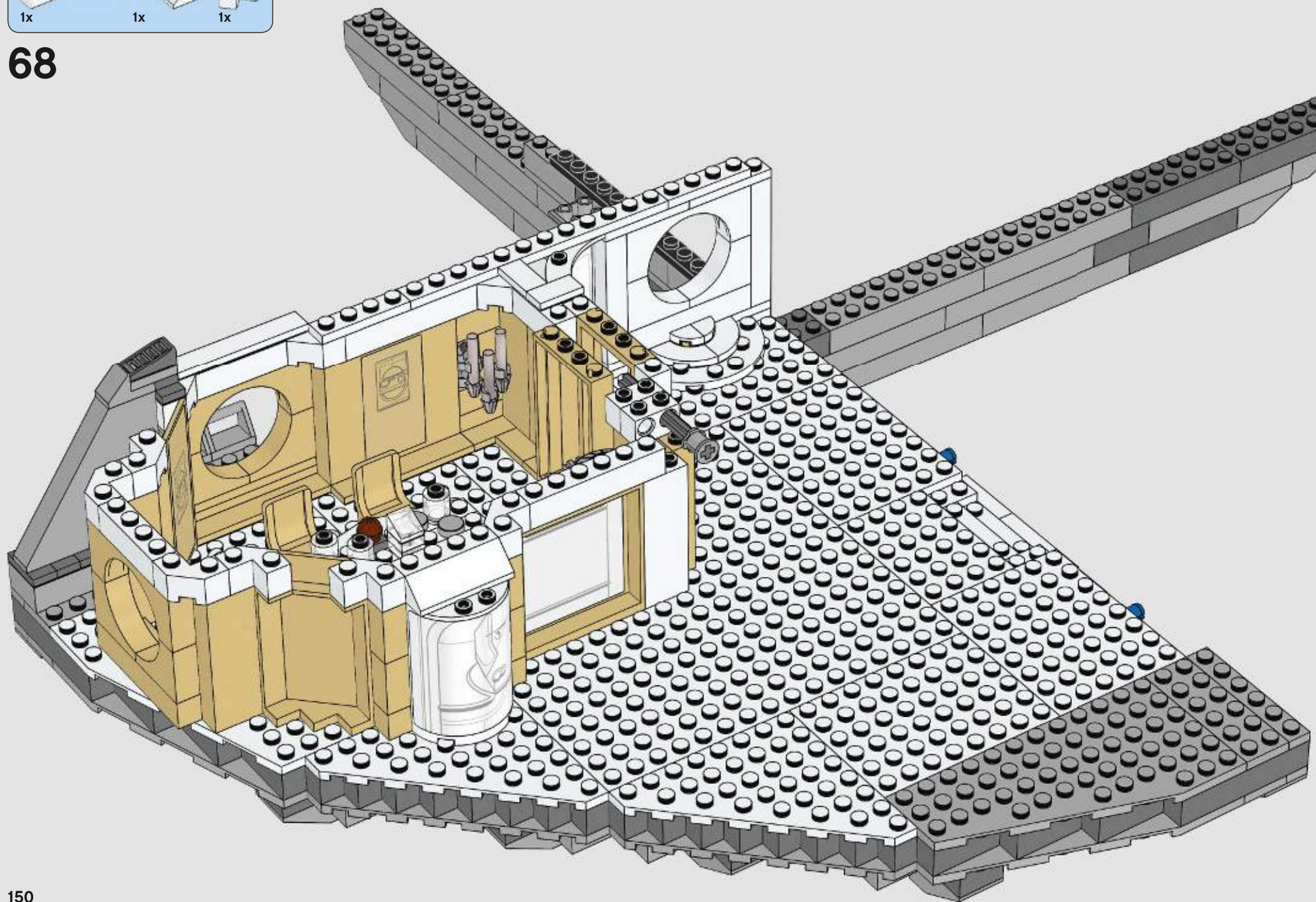



69

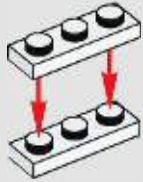

70

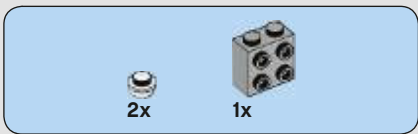
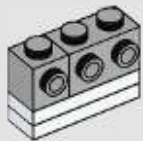

71



72

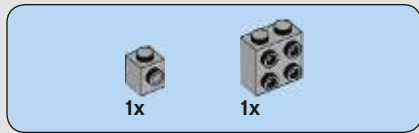
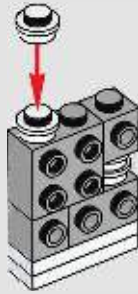

73

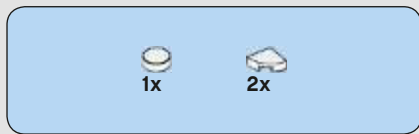
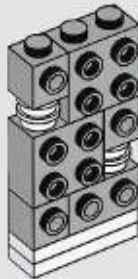

74

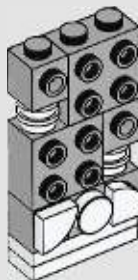

75

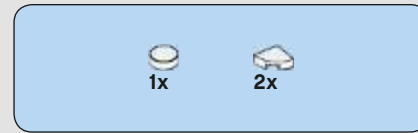
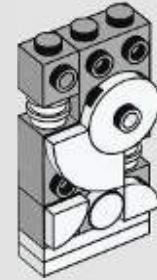

76

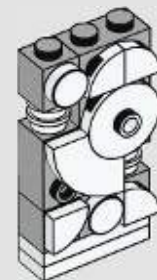

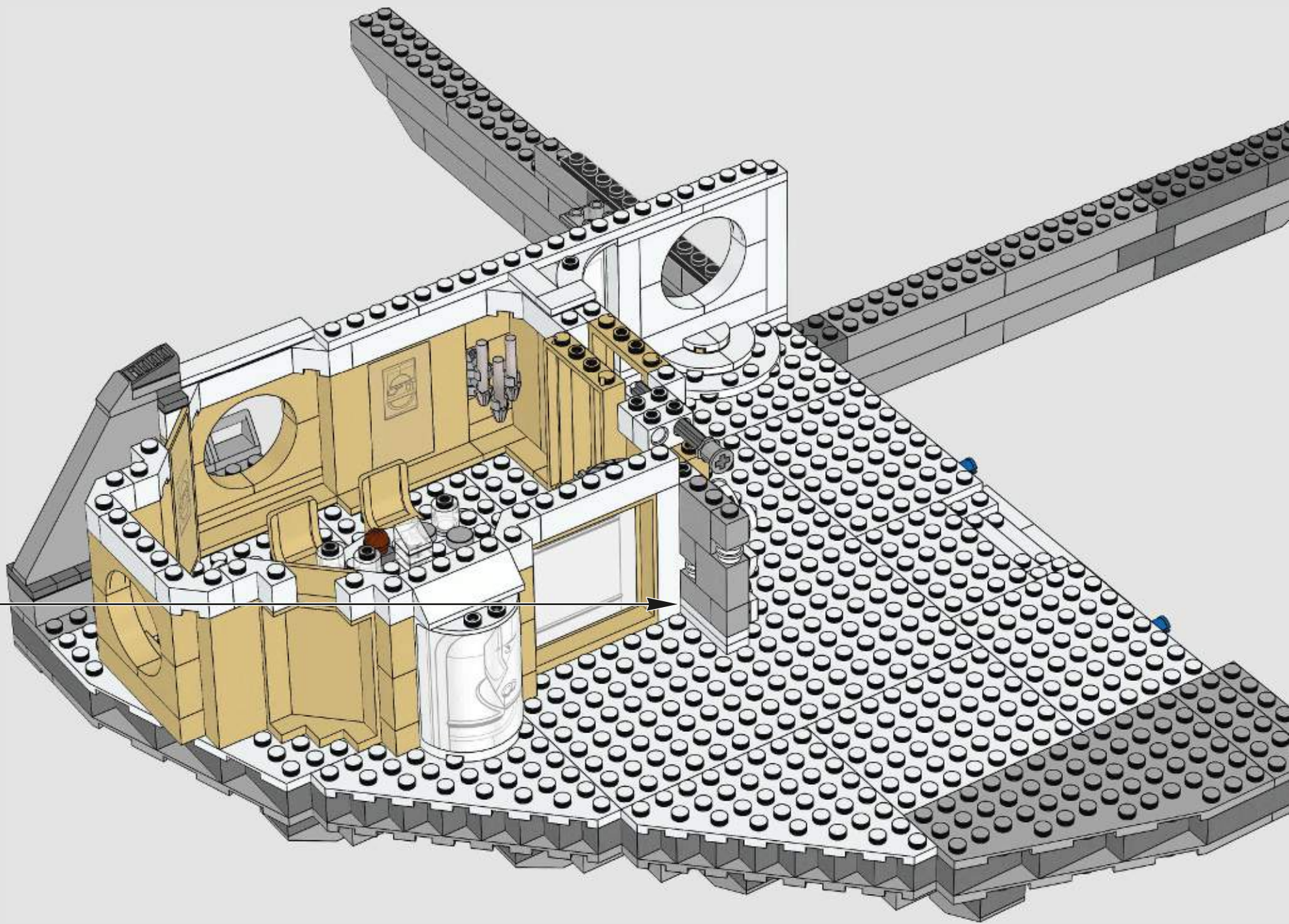



78

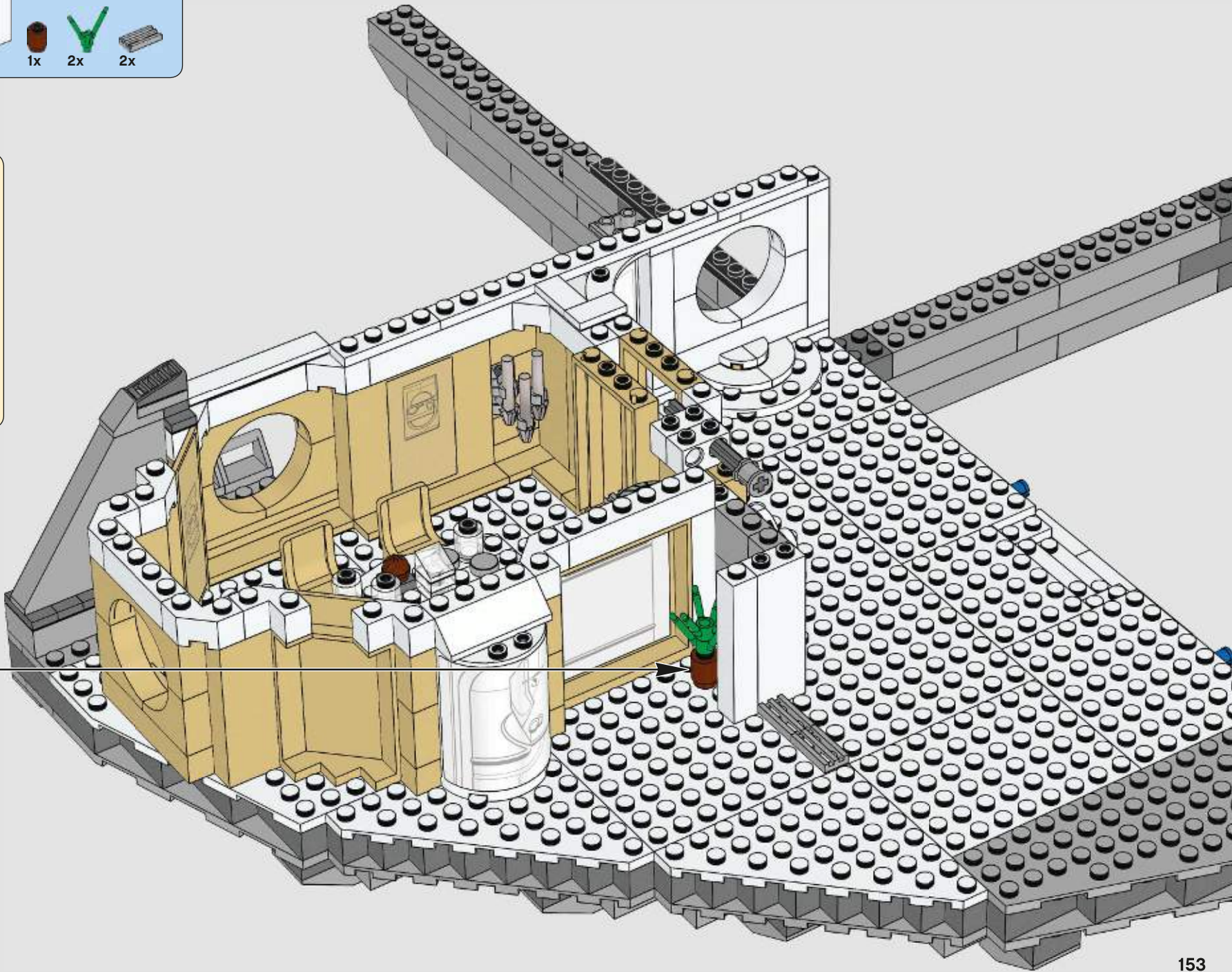
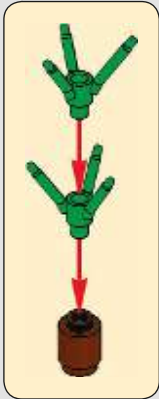

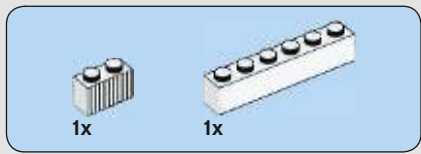

79

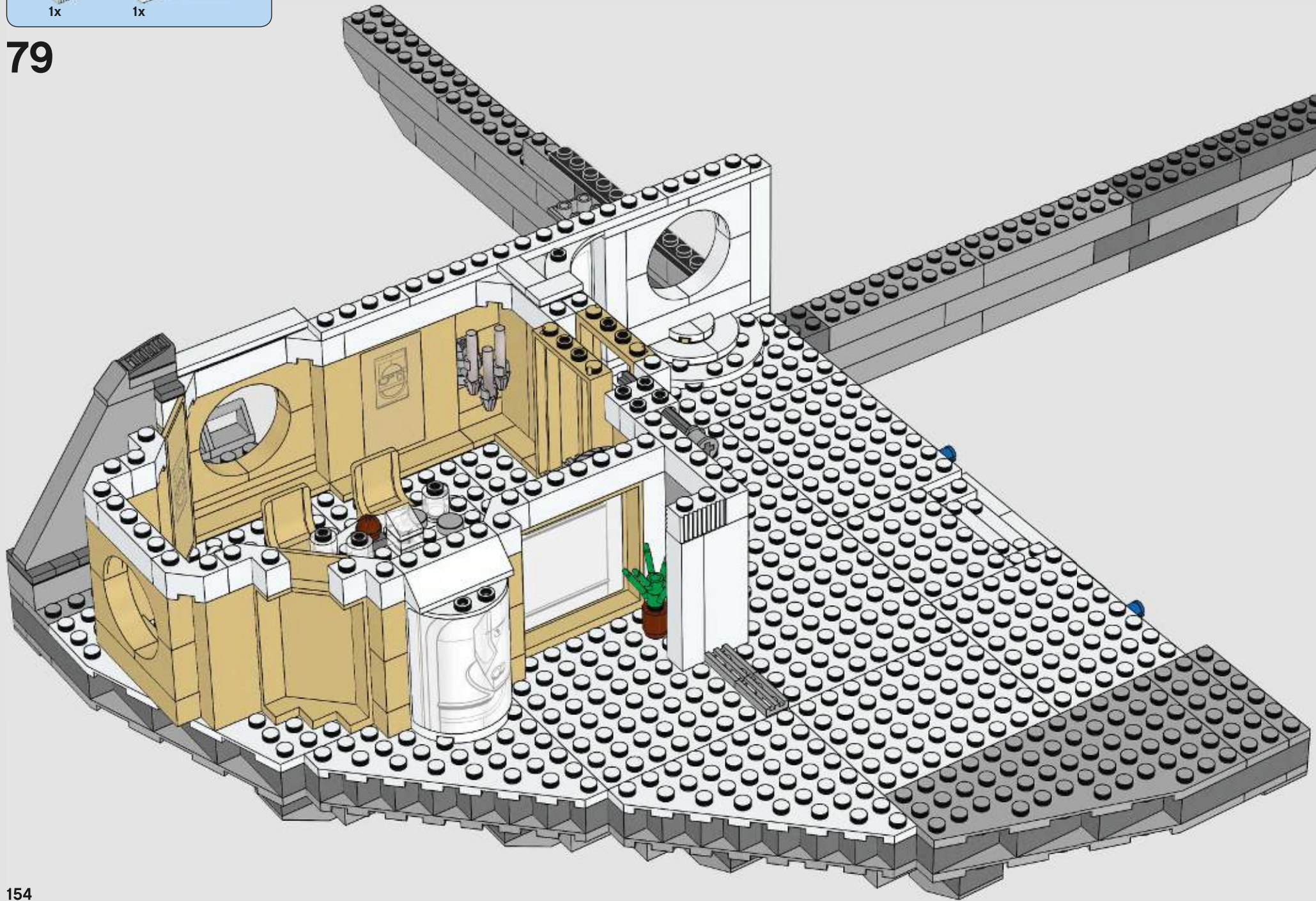

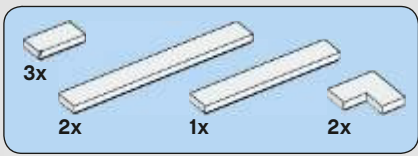

80

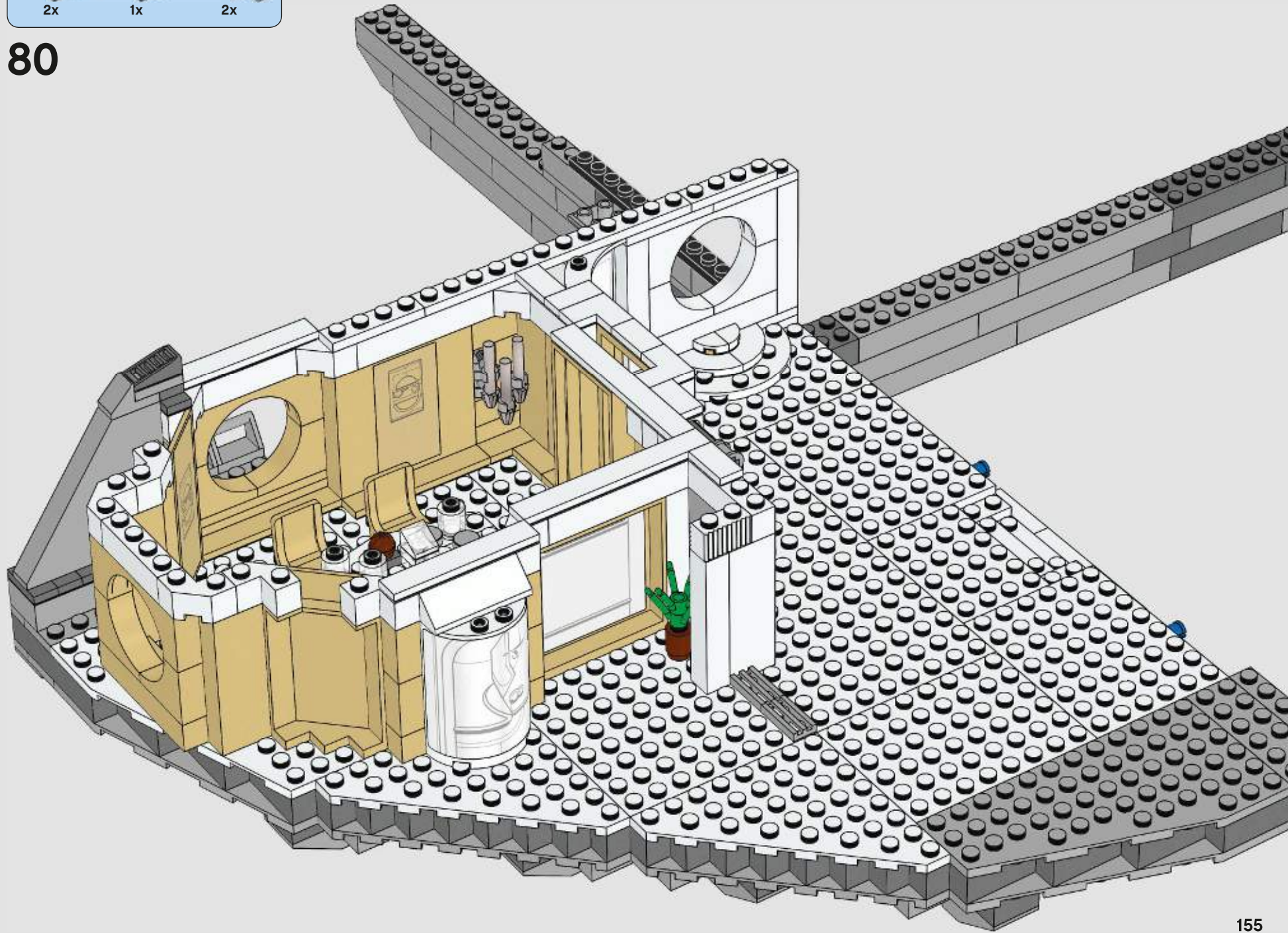

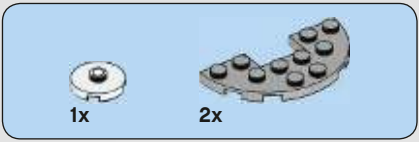

81

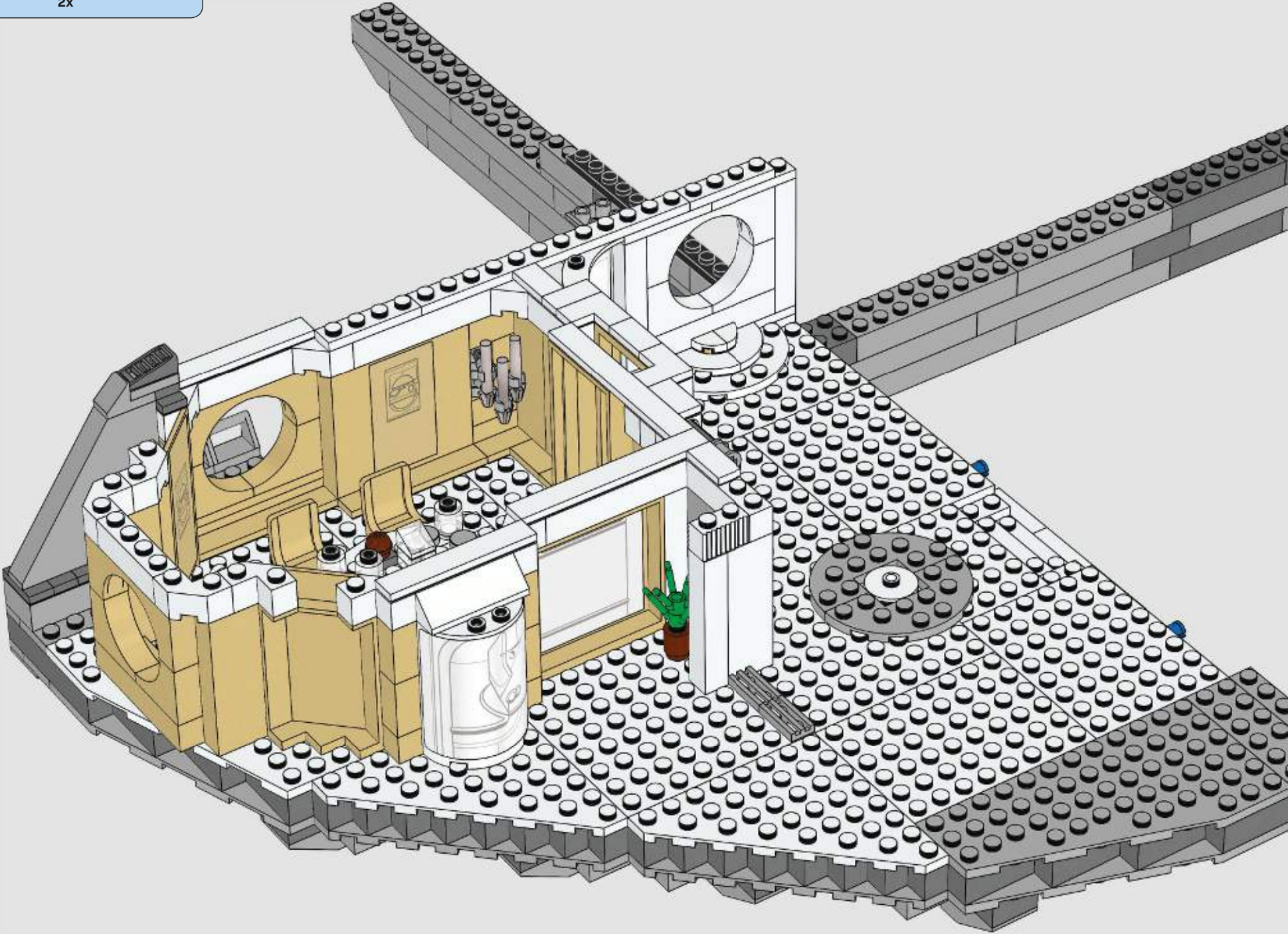



4x

82

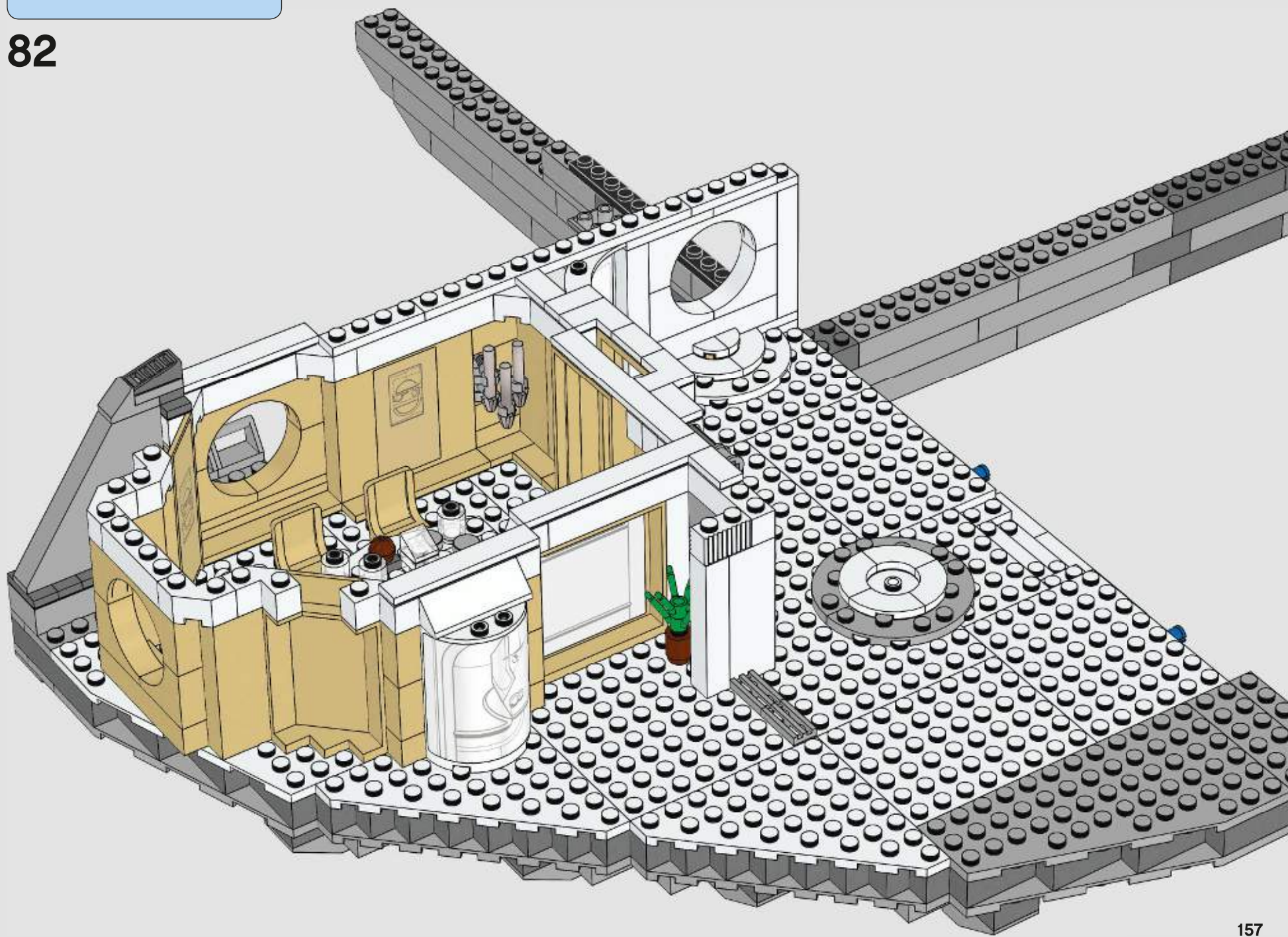



83



84

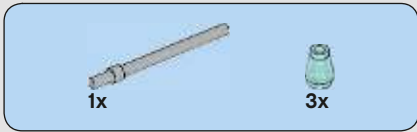
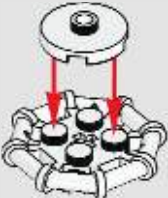

85

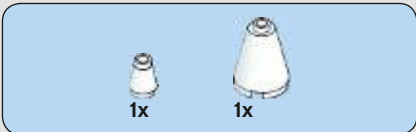
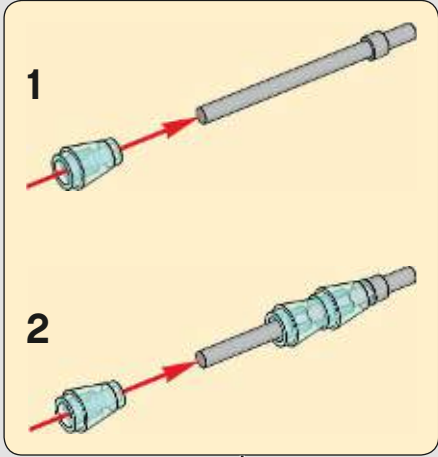

86

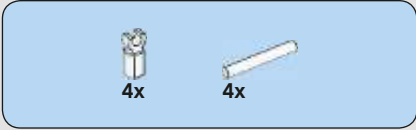
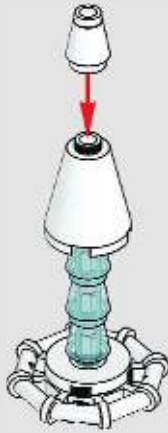

87

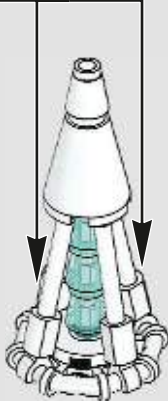
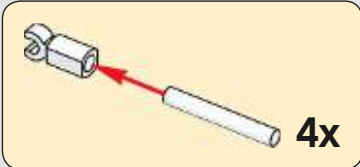

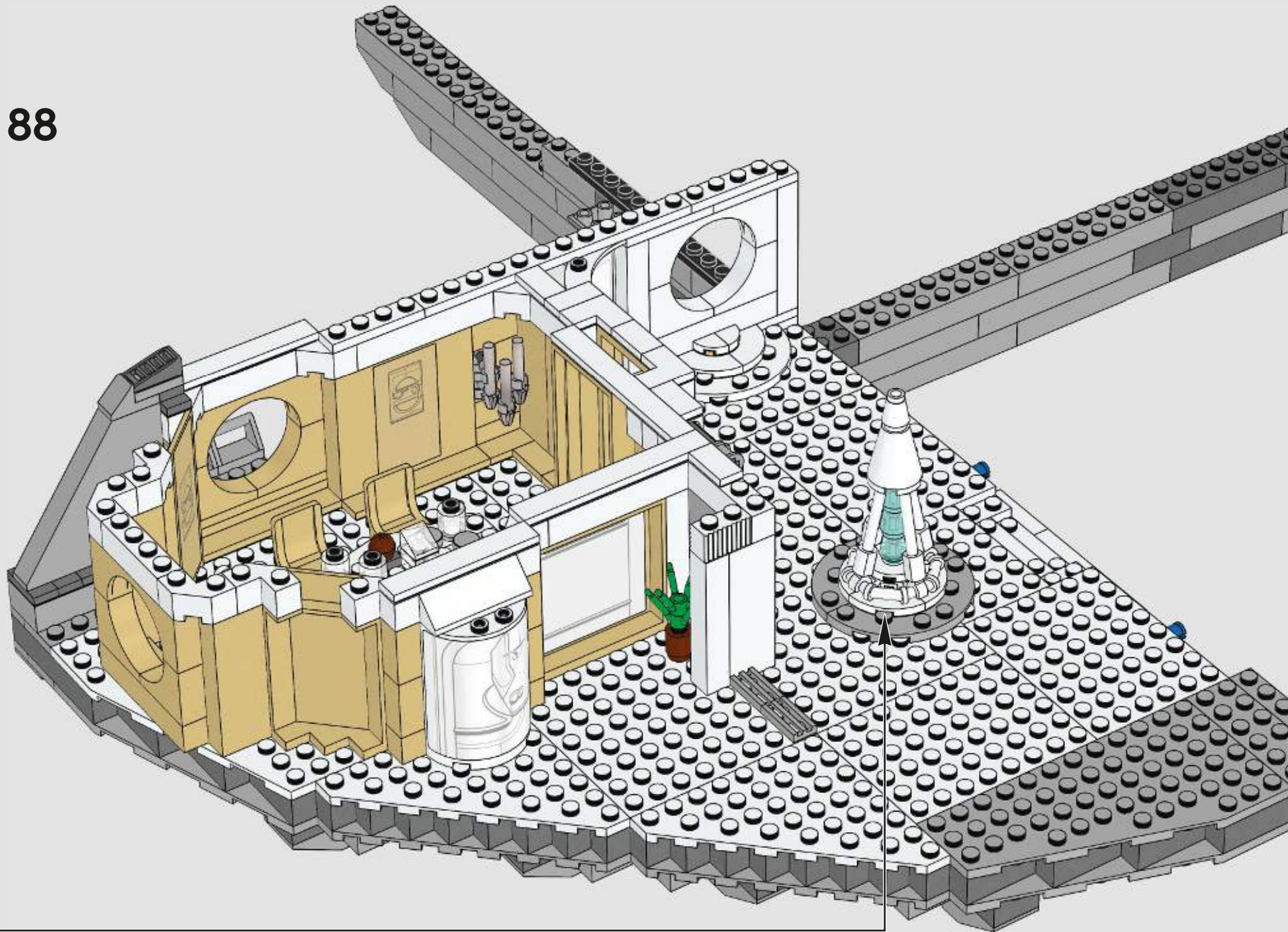

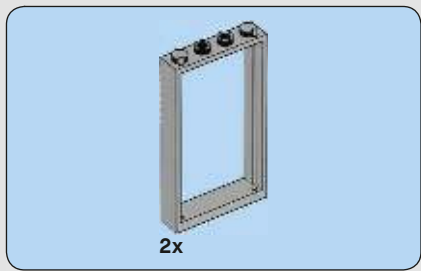

89

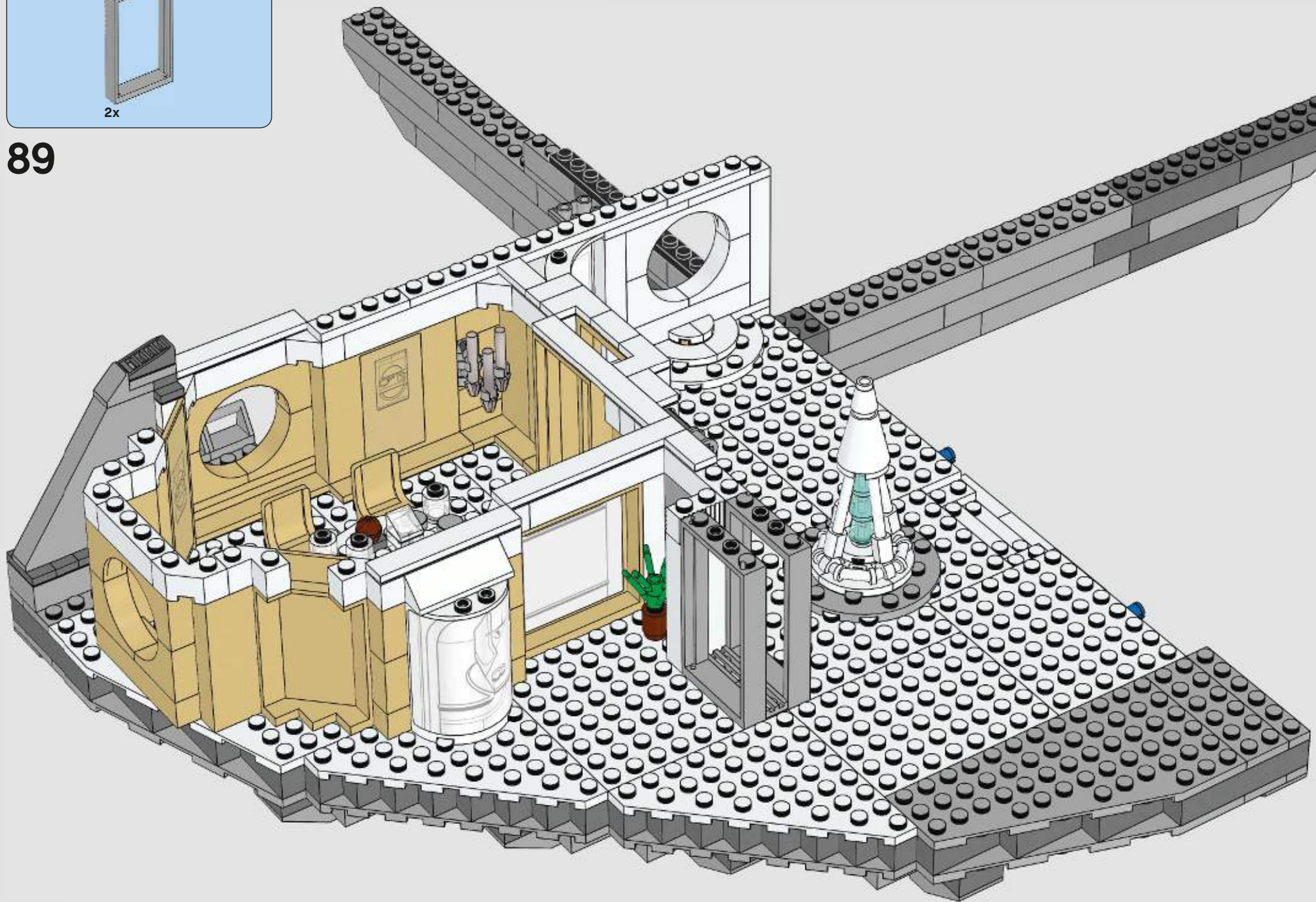



90

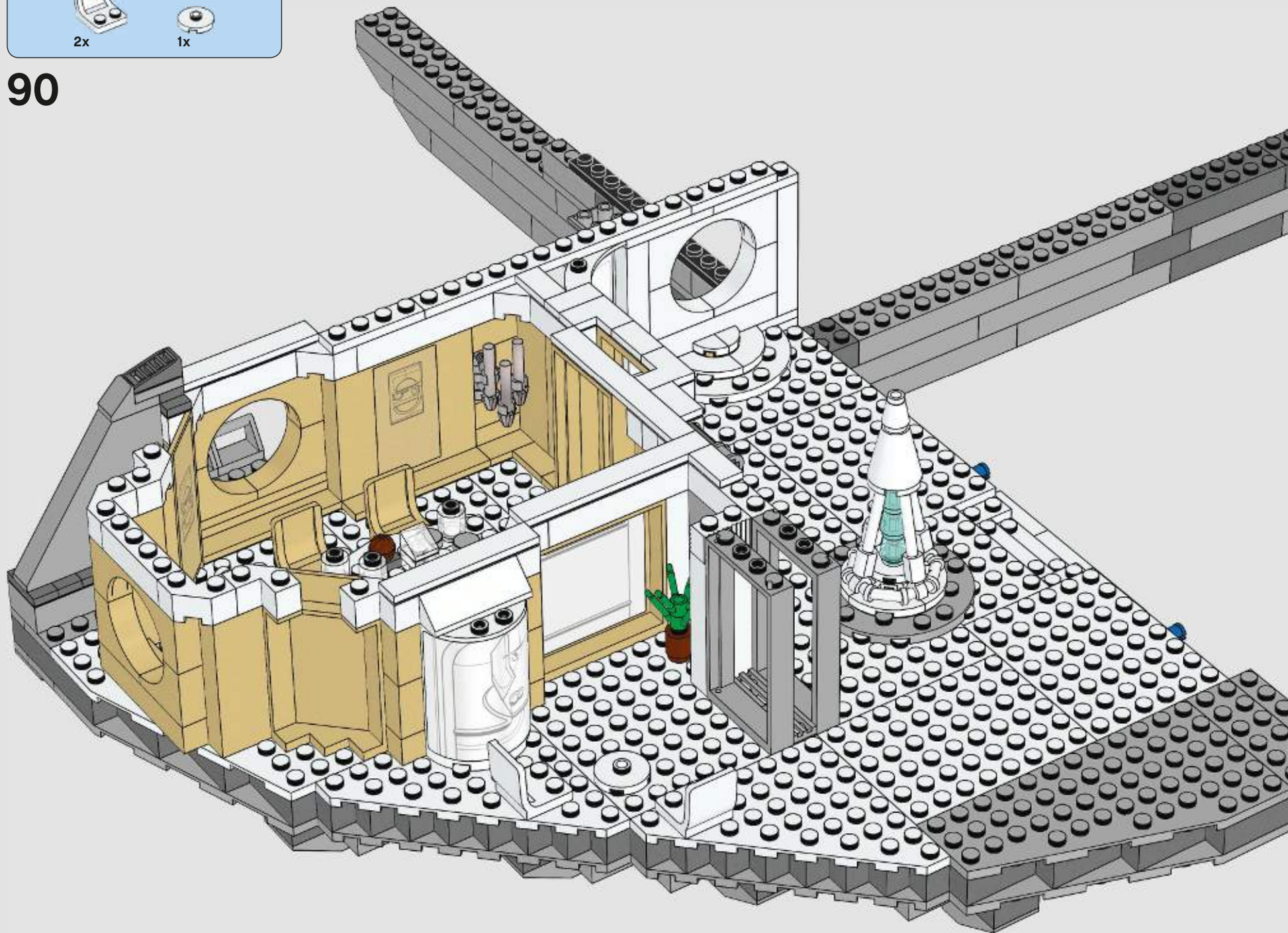

10x 4x 2x

91

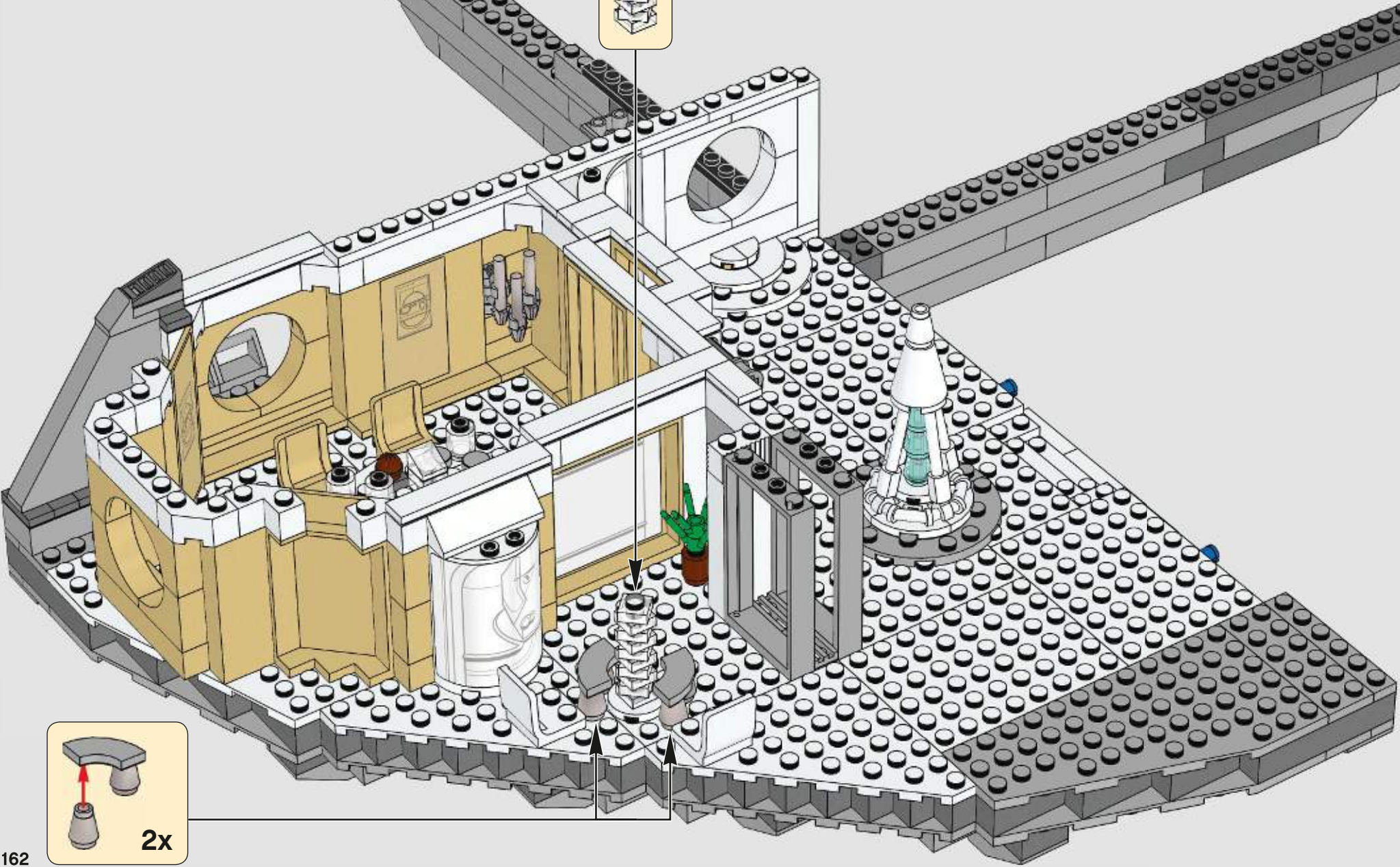

2x

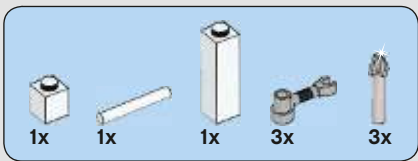

92

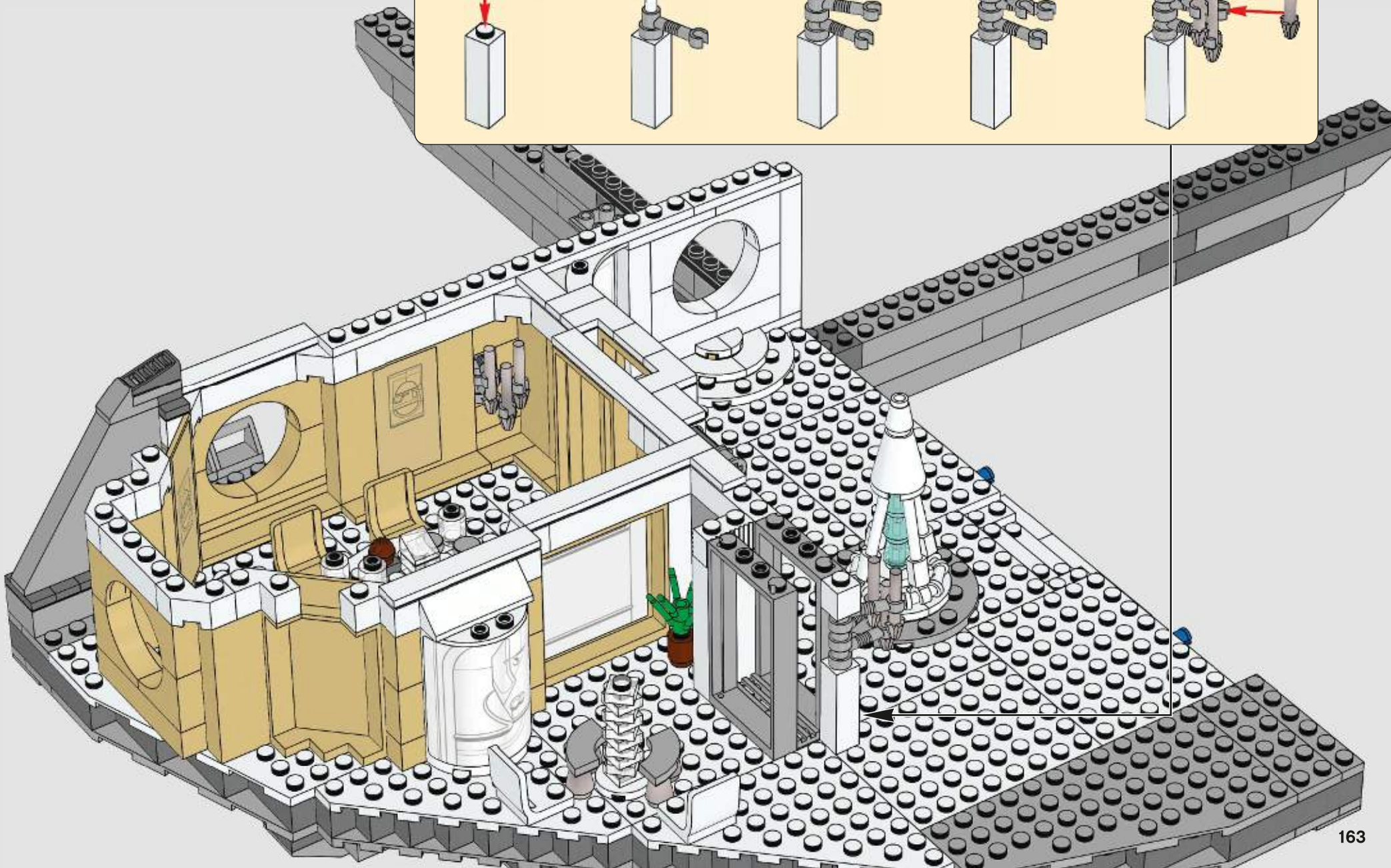
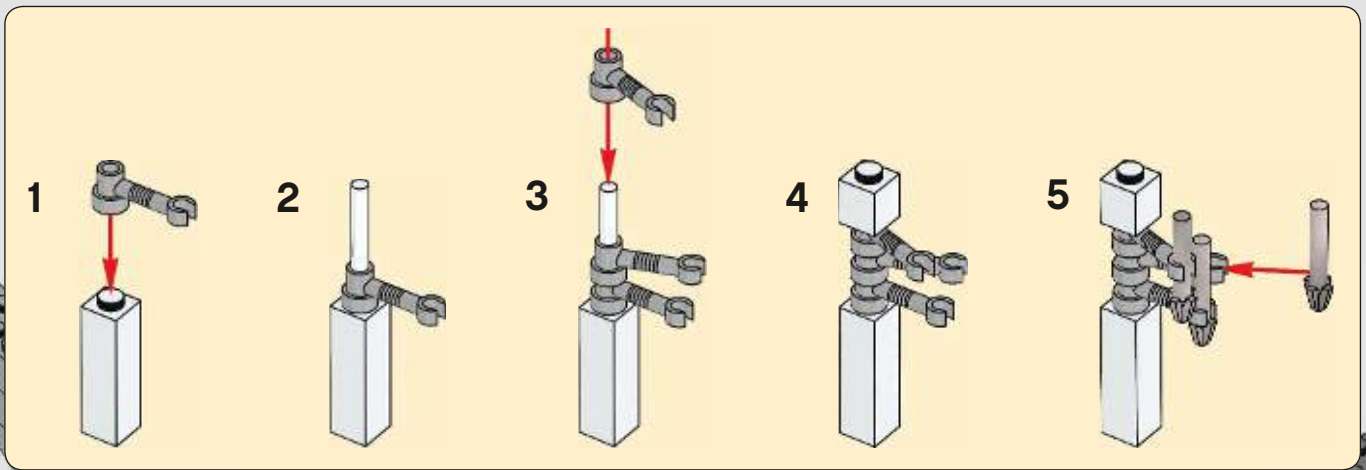

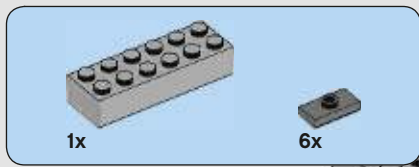

93

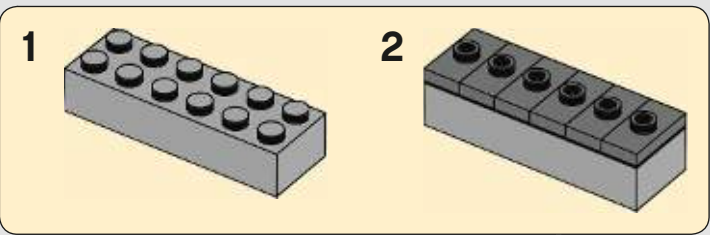

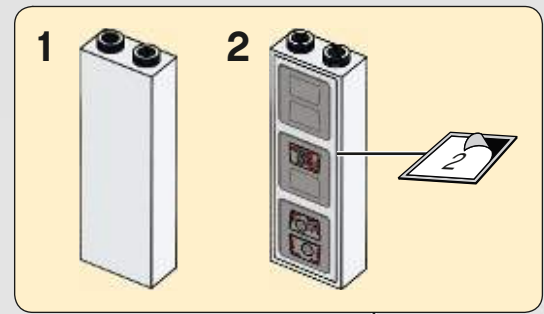
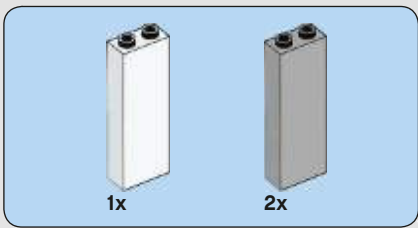

94

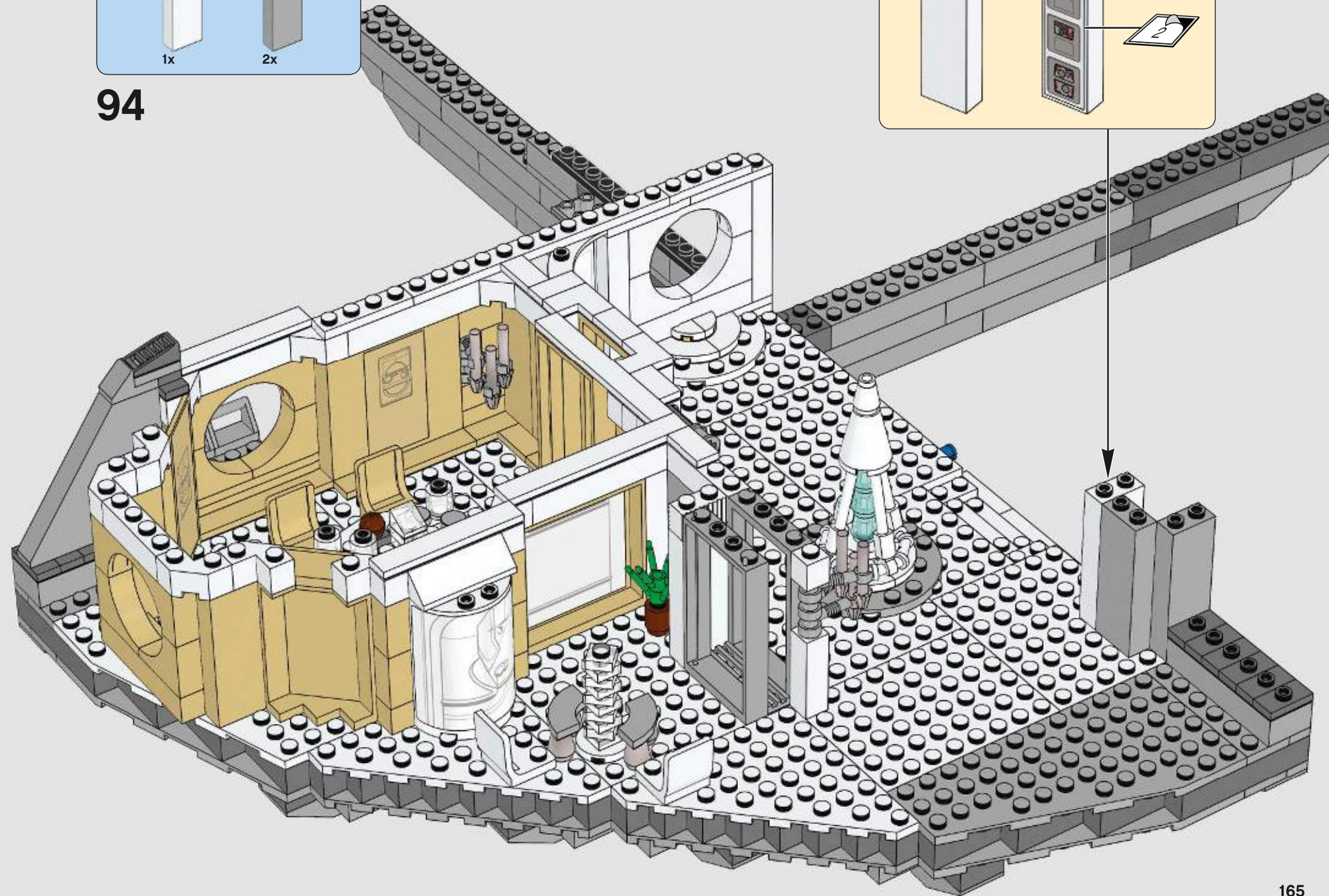

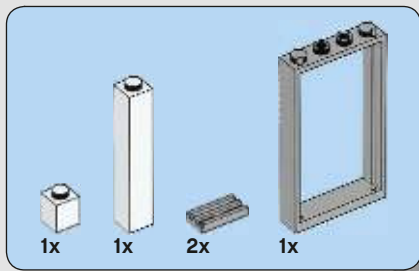

95

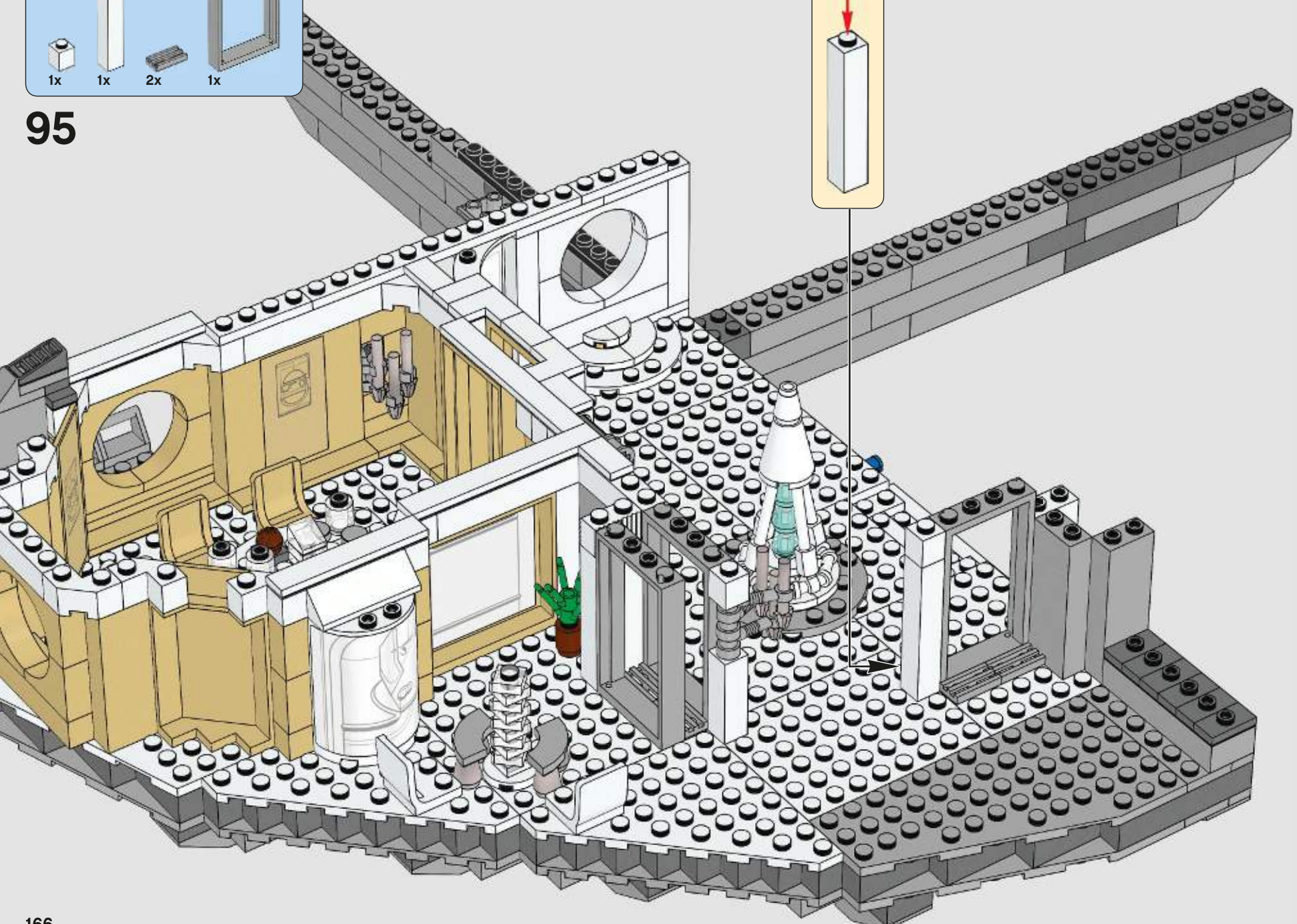
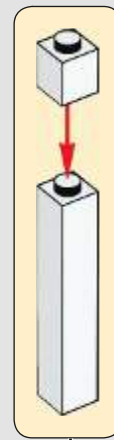

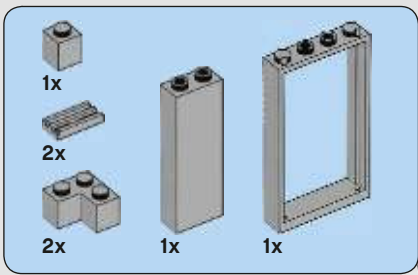

96

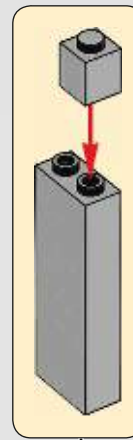

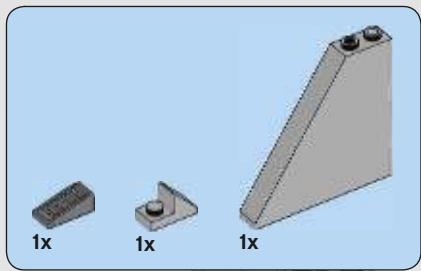

97

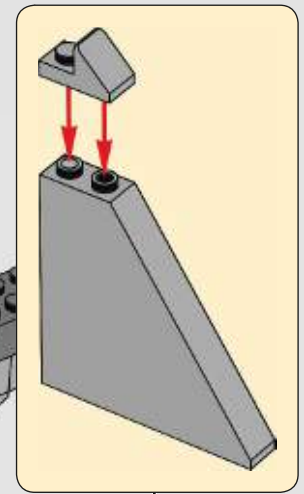
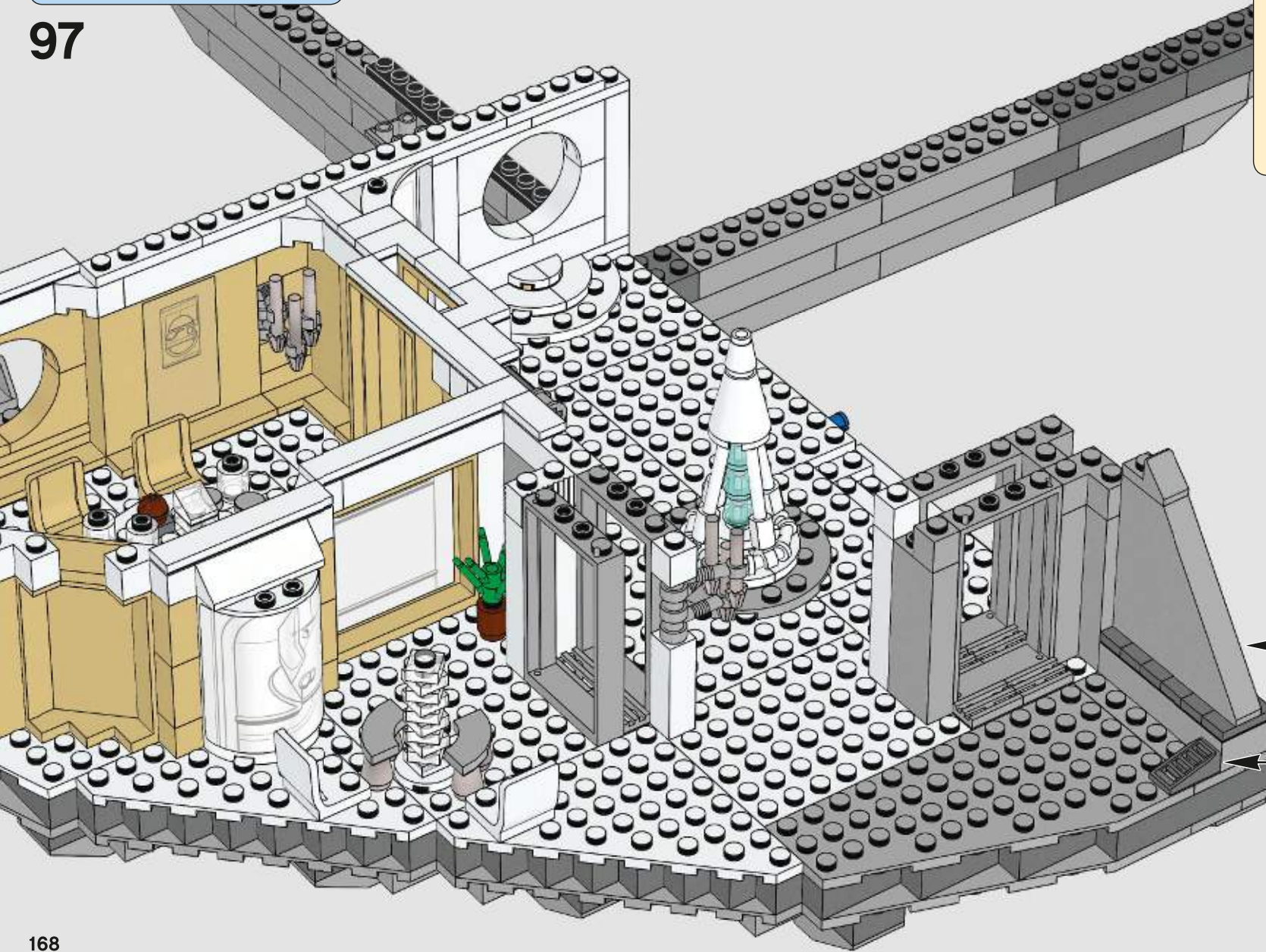



98

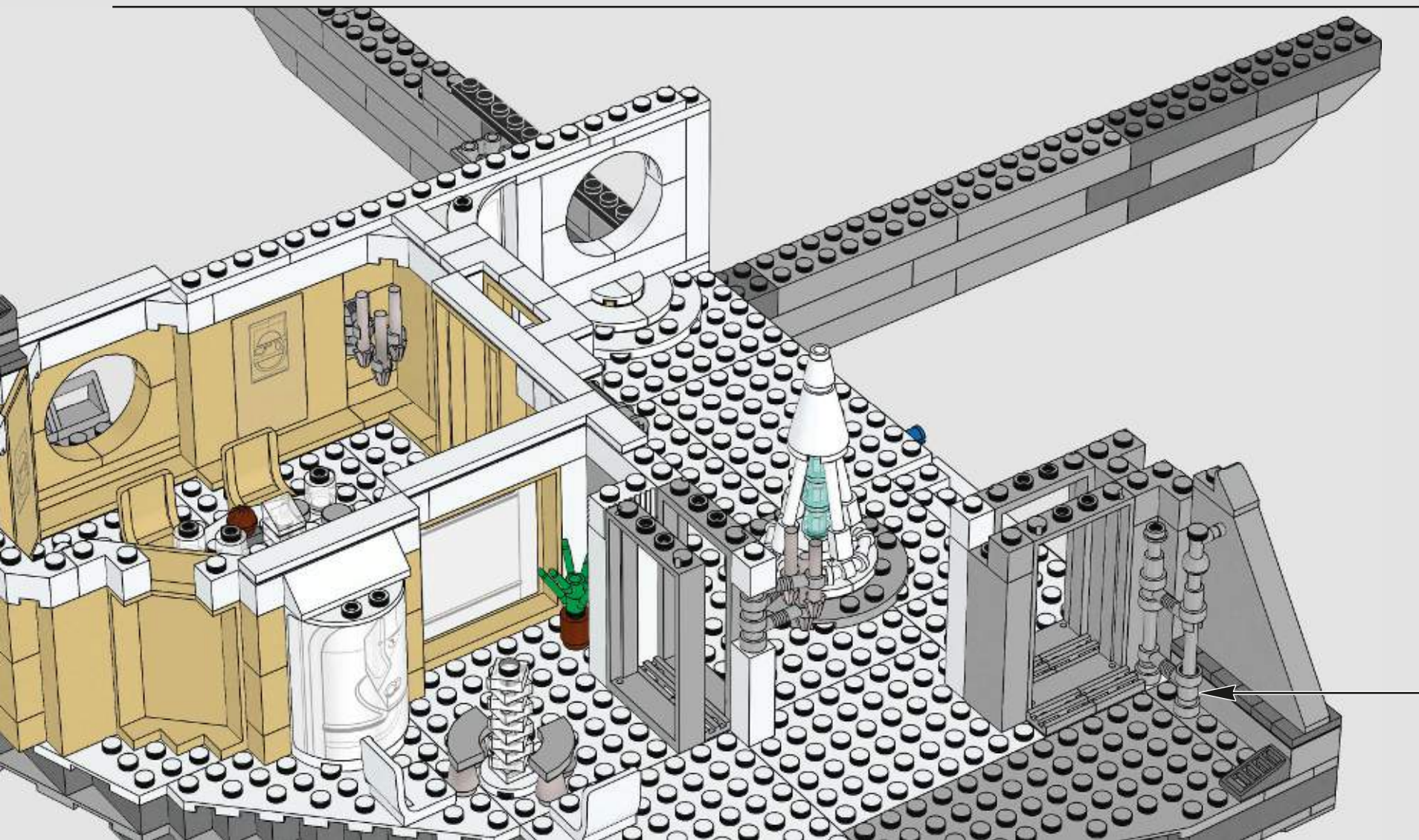
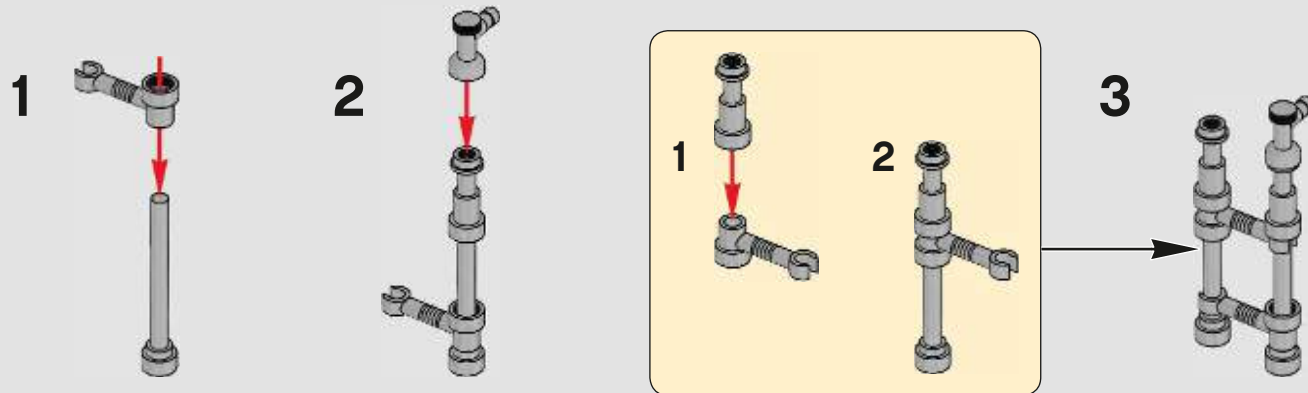

3x 1x 1x

99

1 2

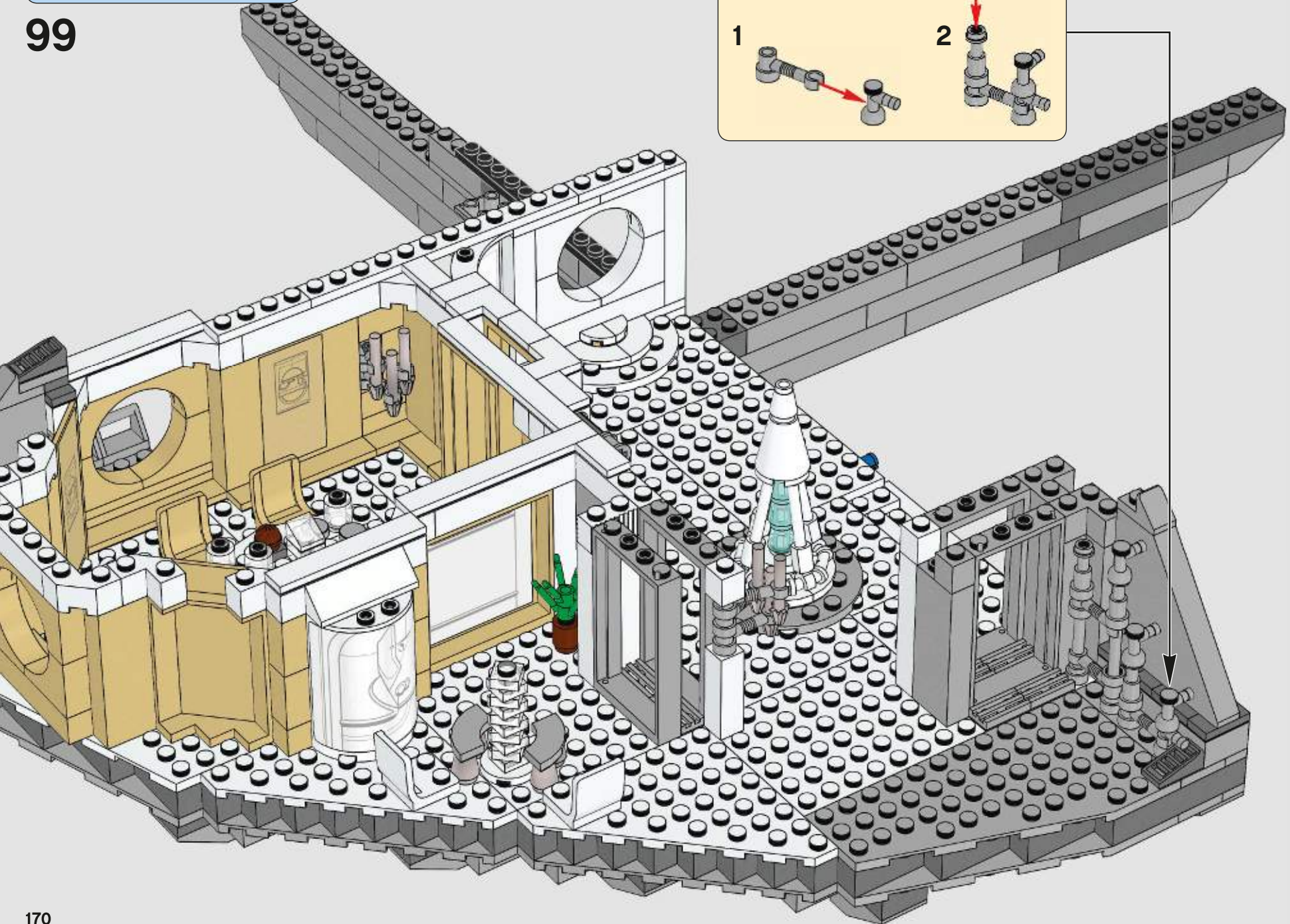

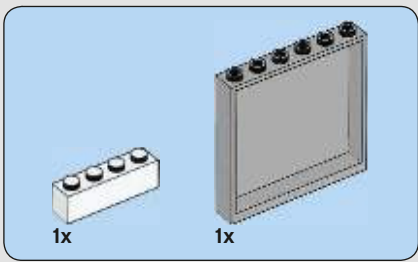

100

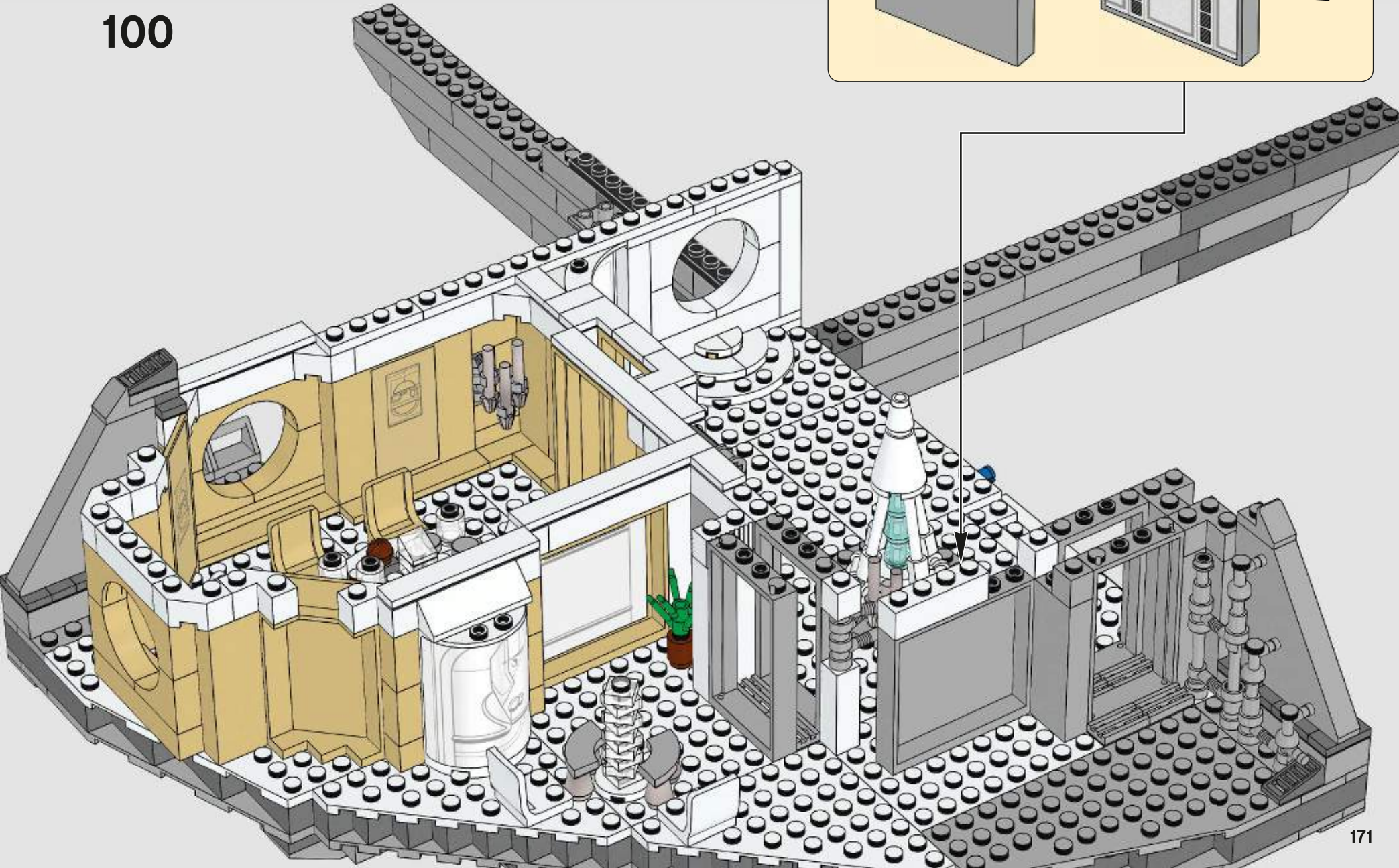
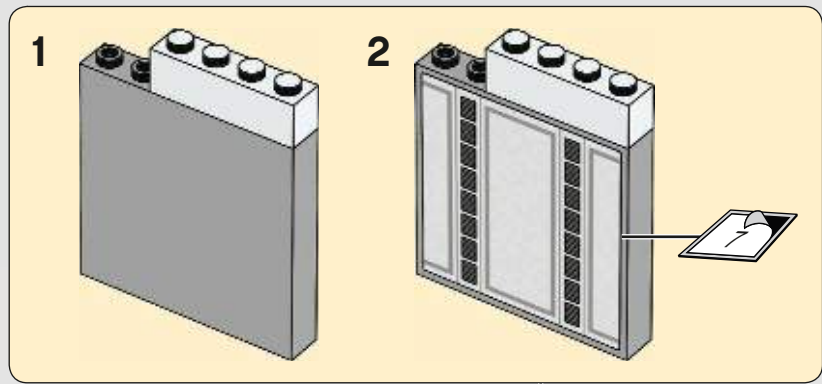

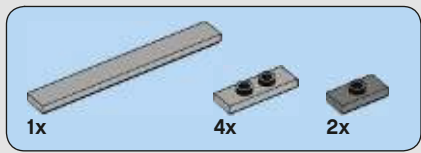

101

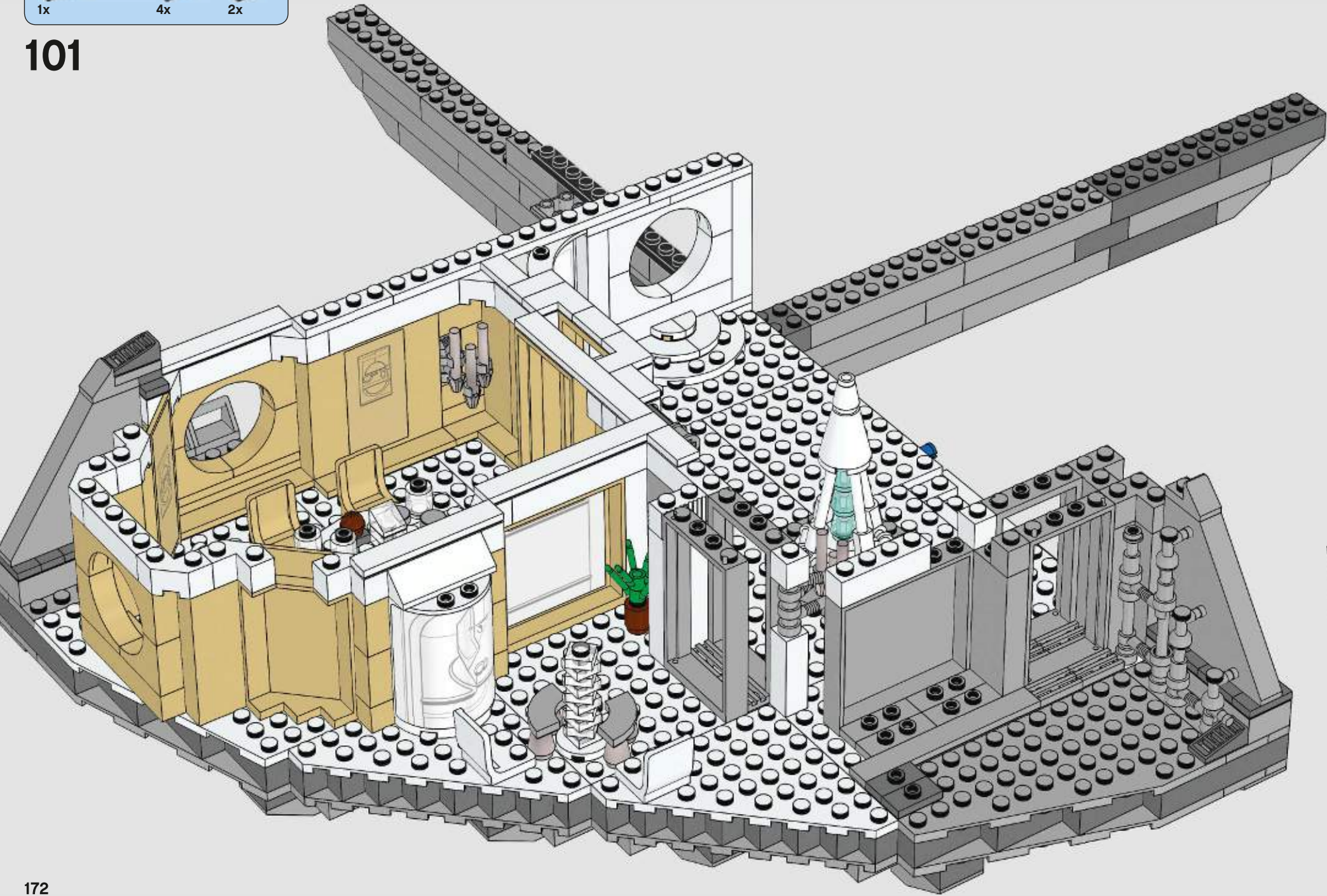

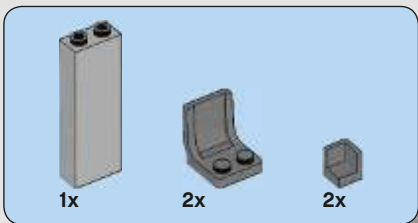

102

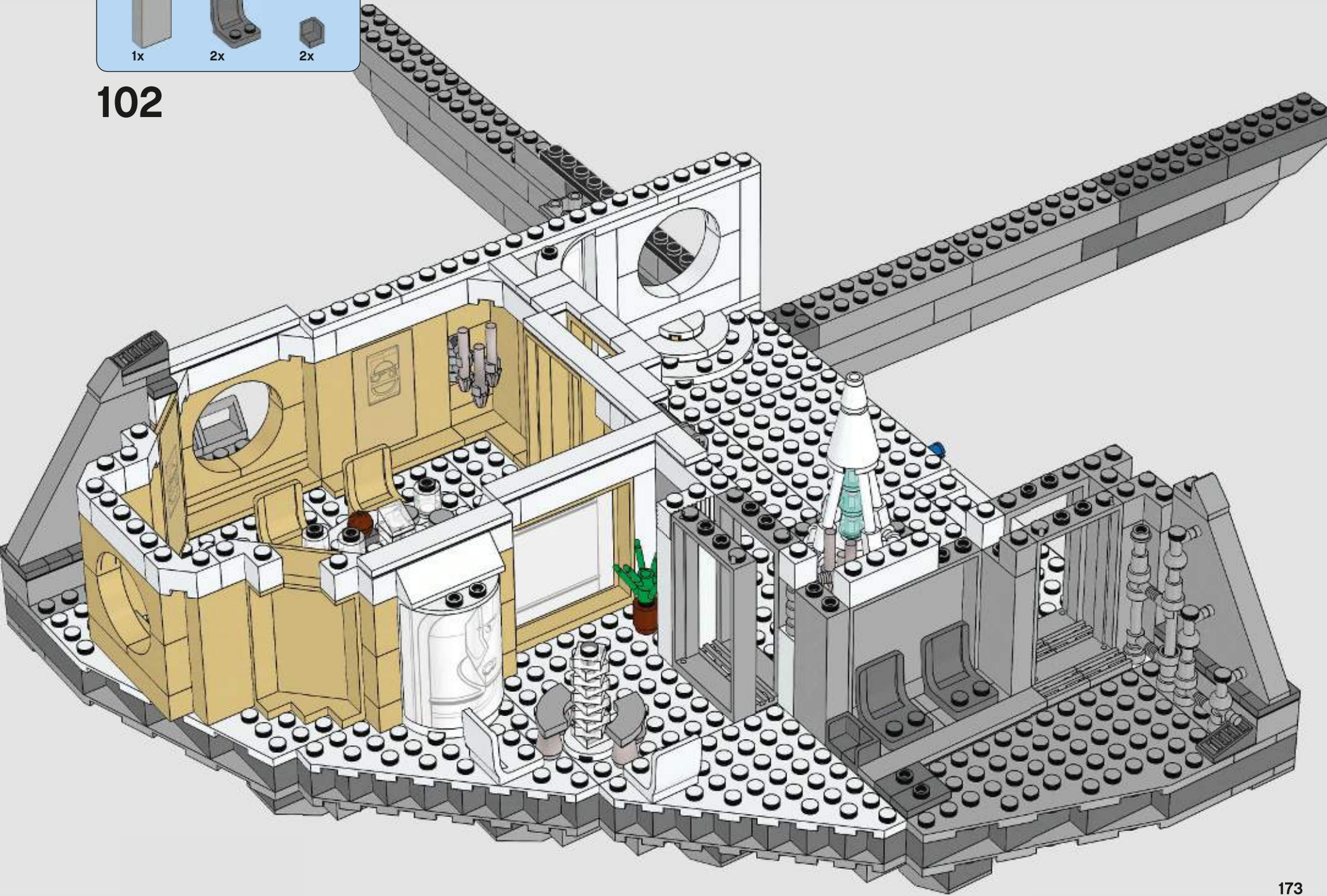

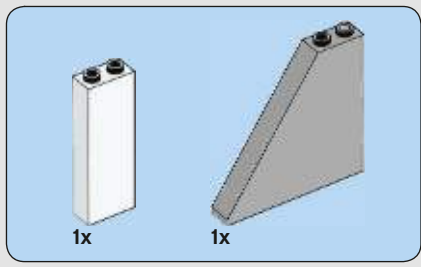

103

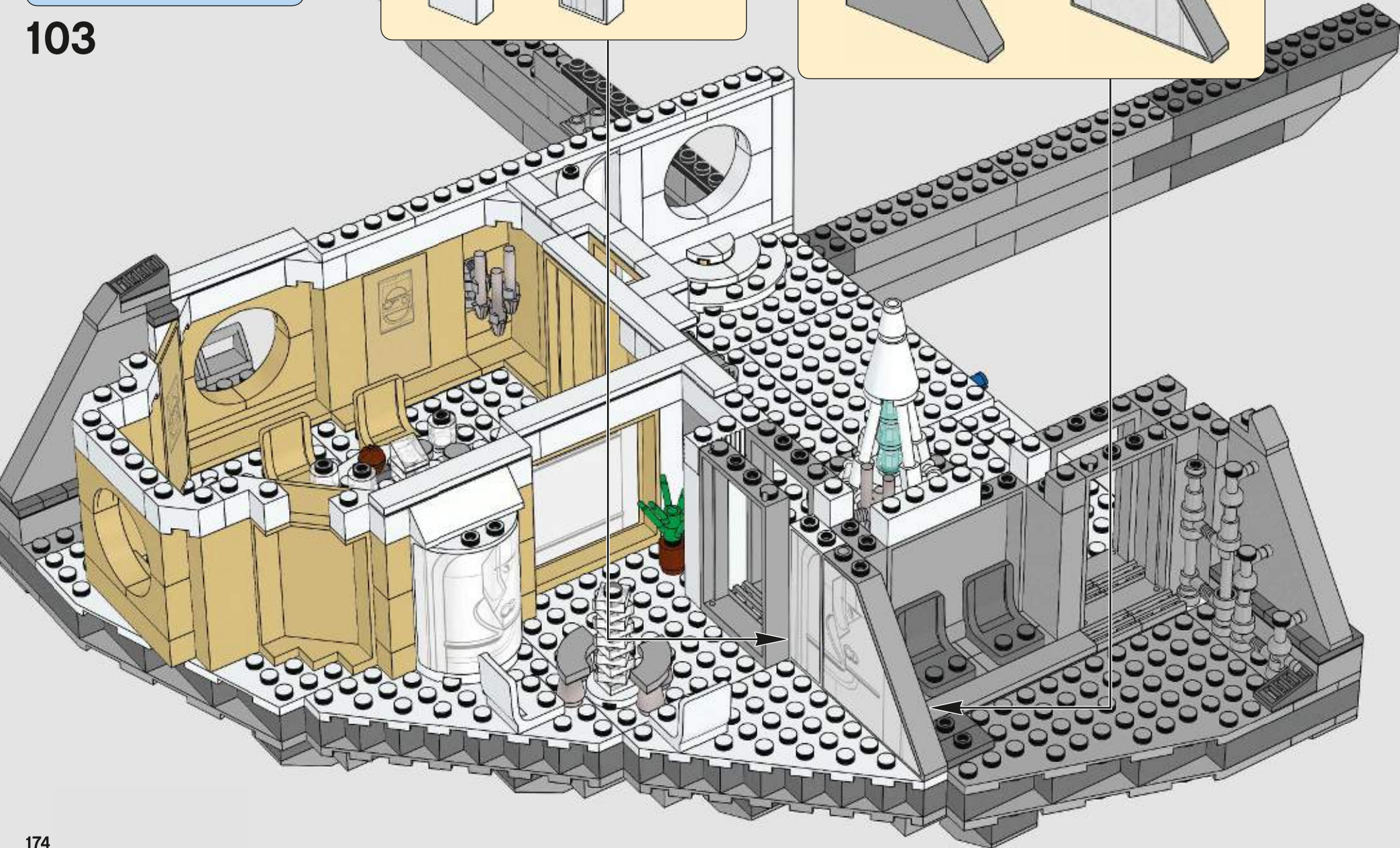
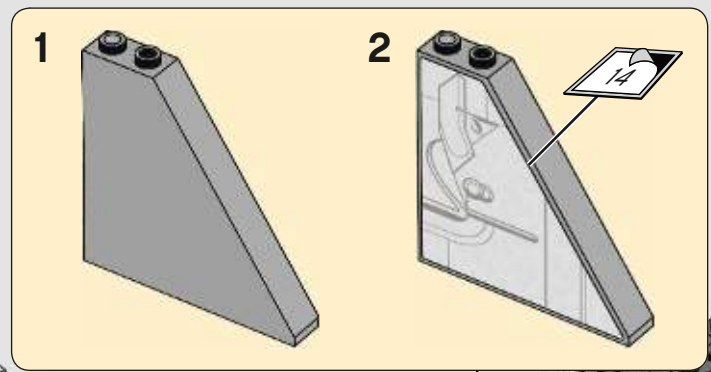
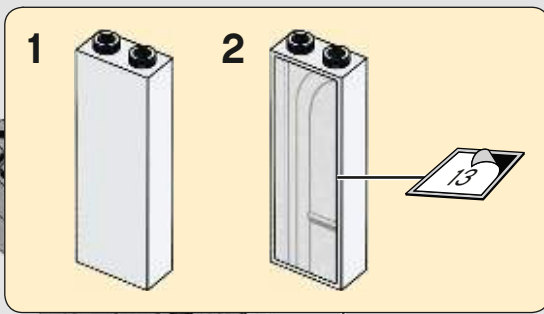

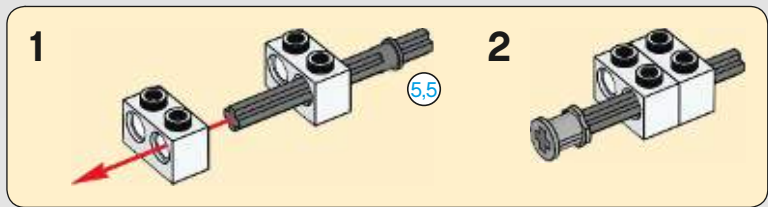
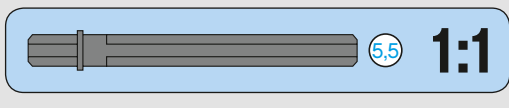
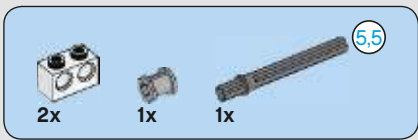

104

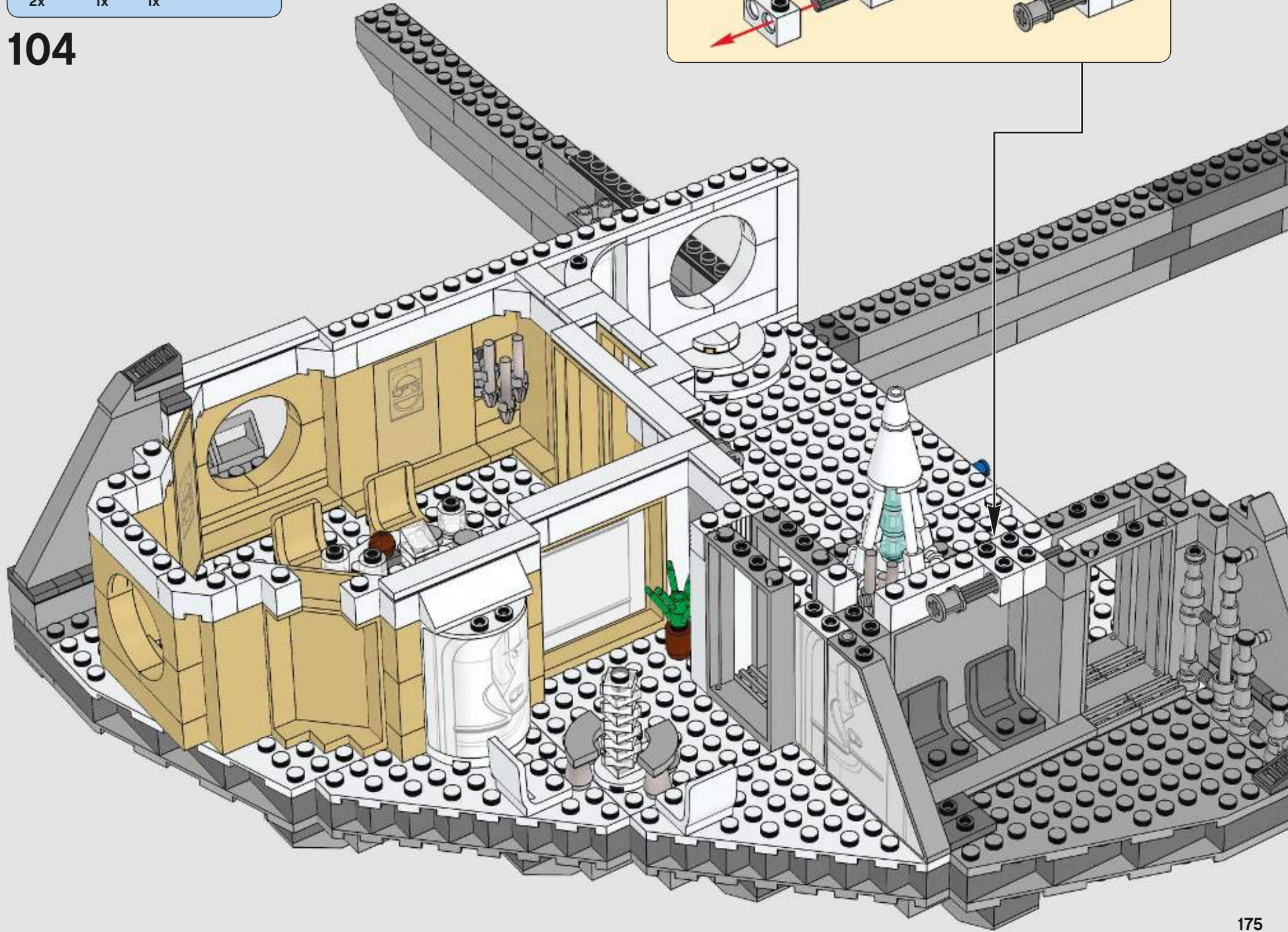

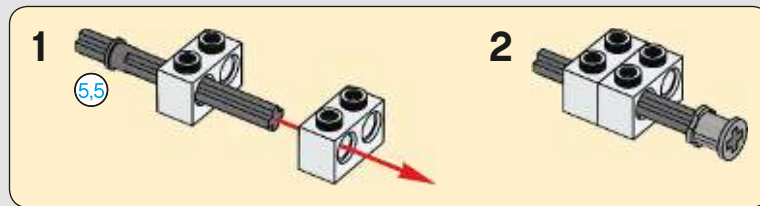
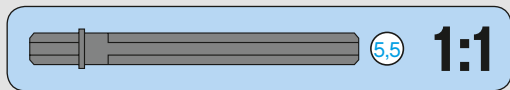
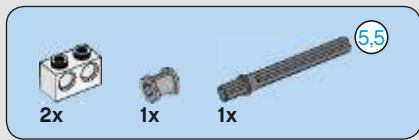

105

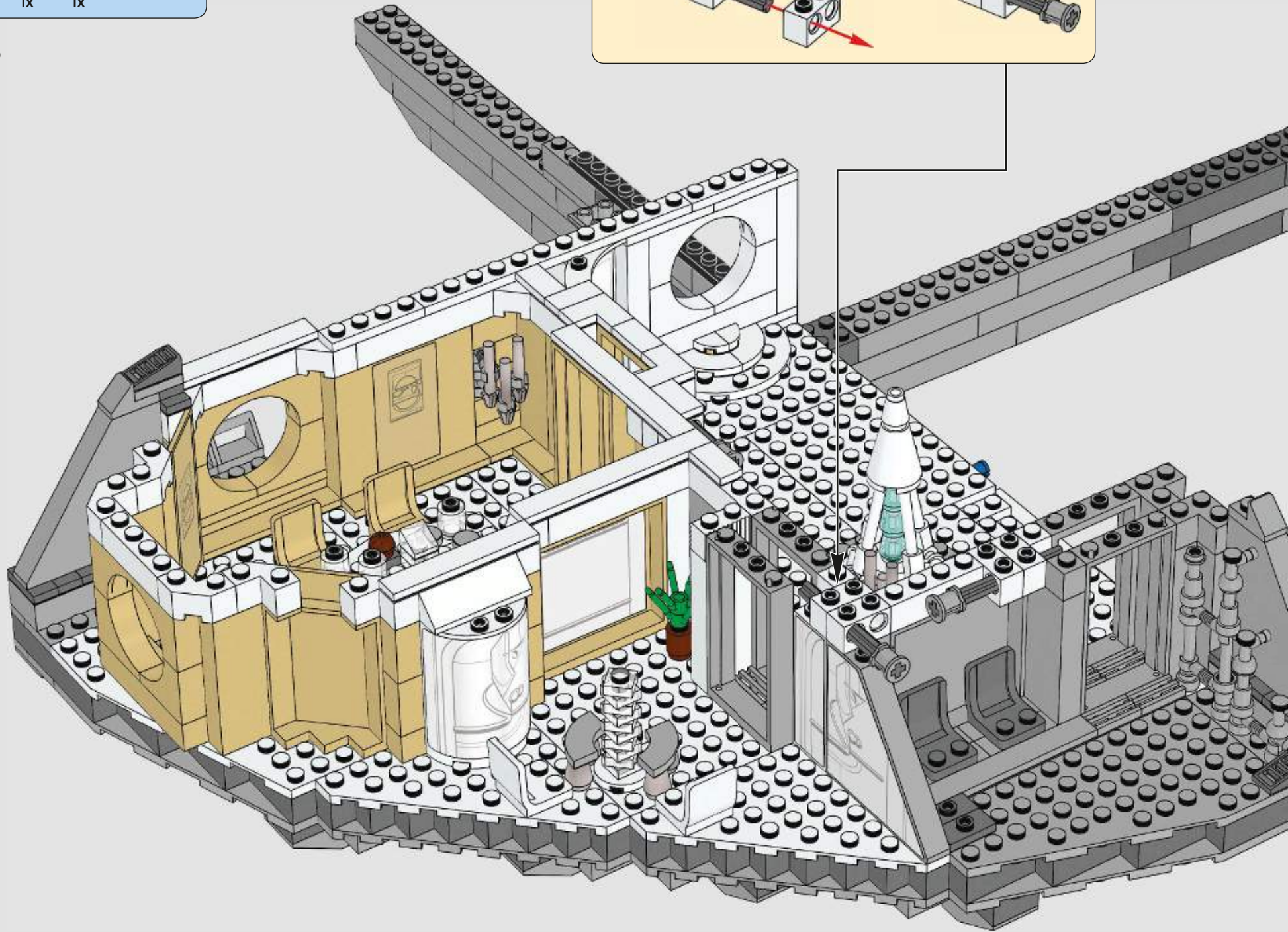

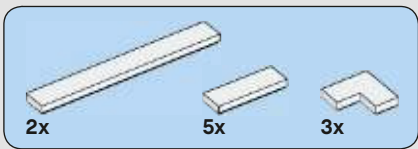

106

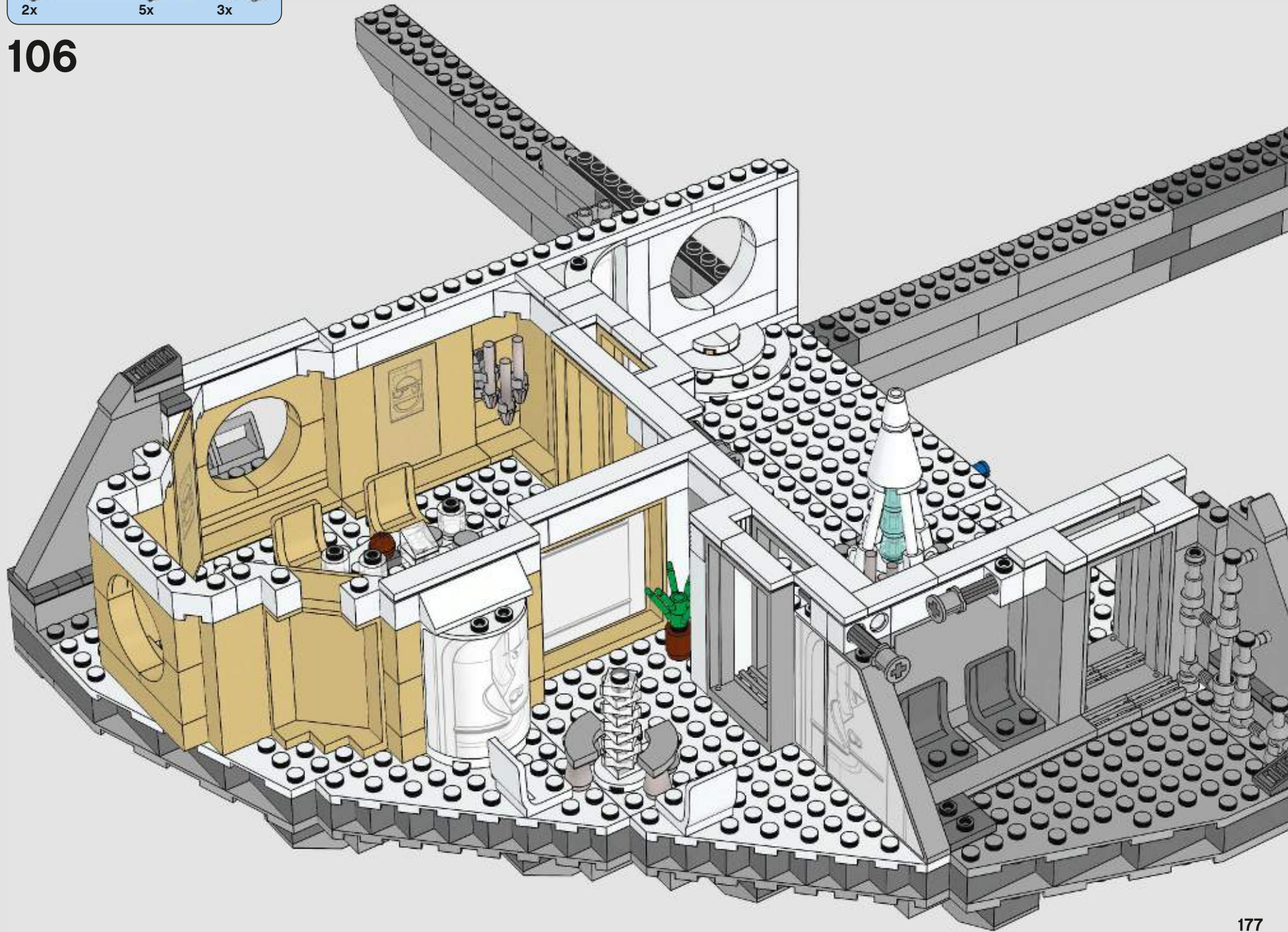

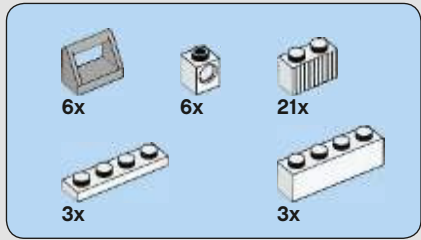
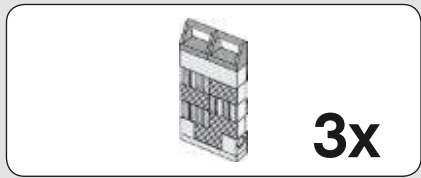

107

1

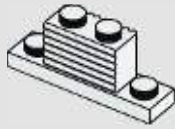

2



3

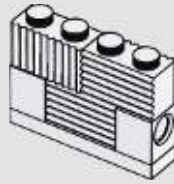

4

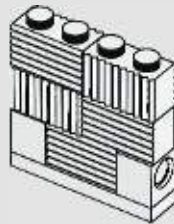

5

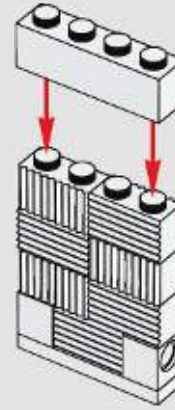

6

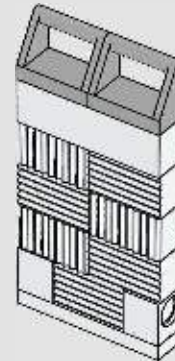

3x

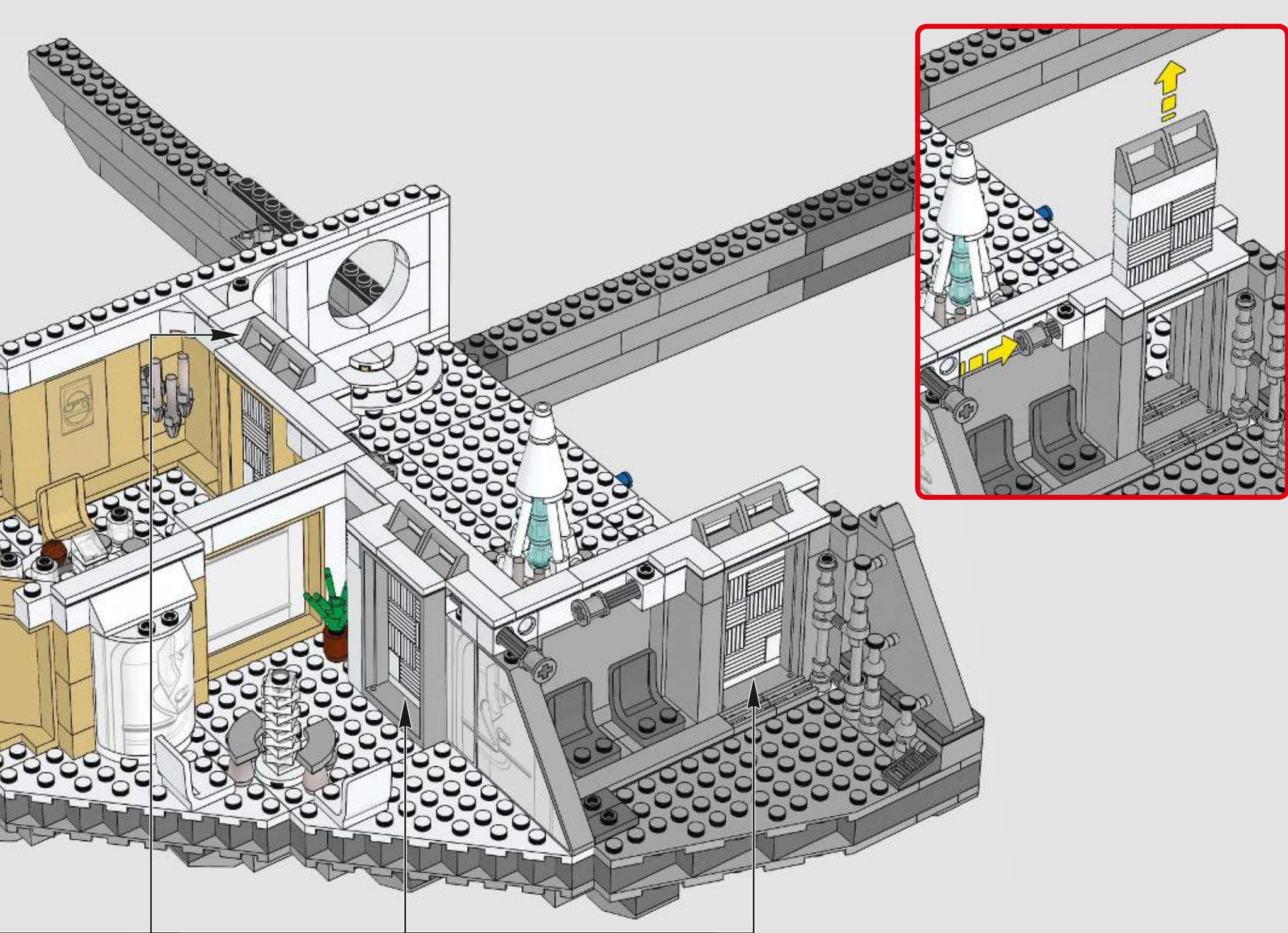

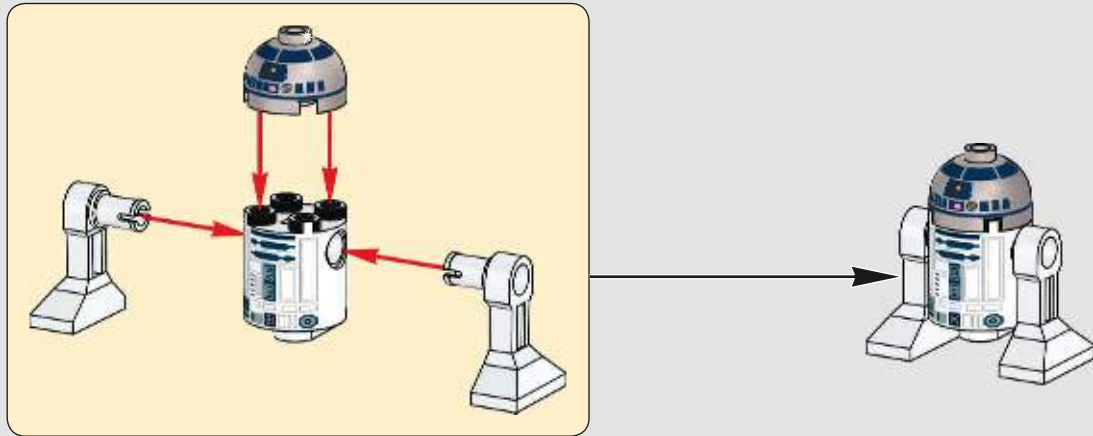
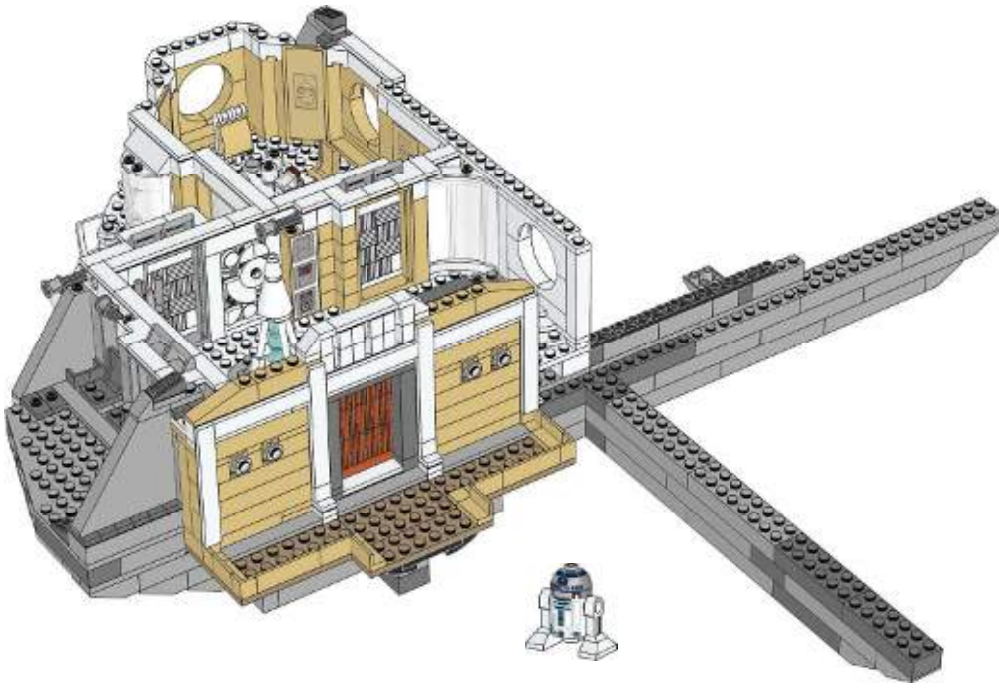

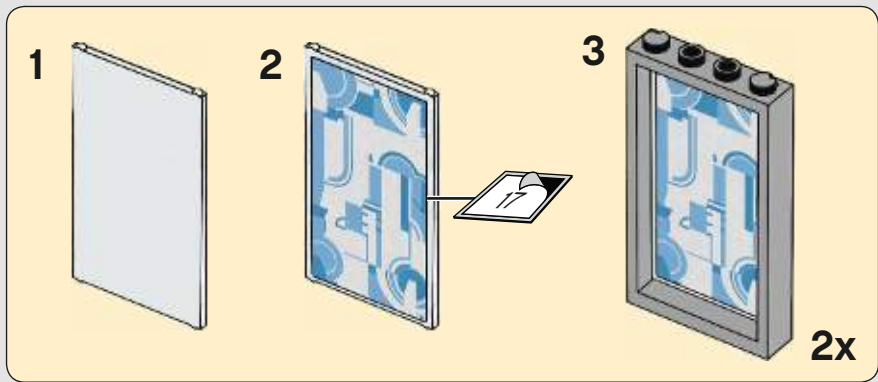
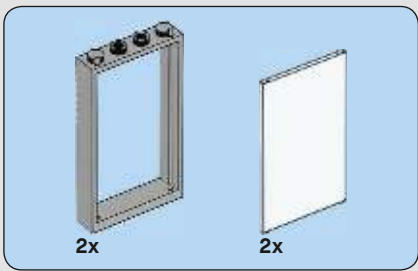

108



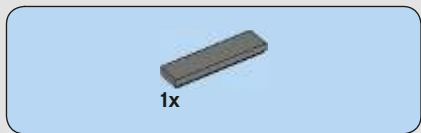

109

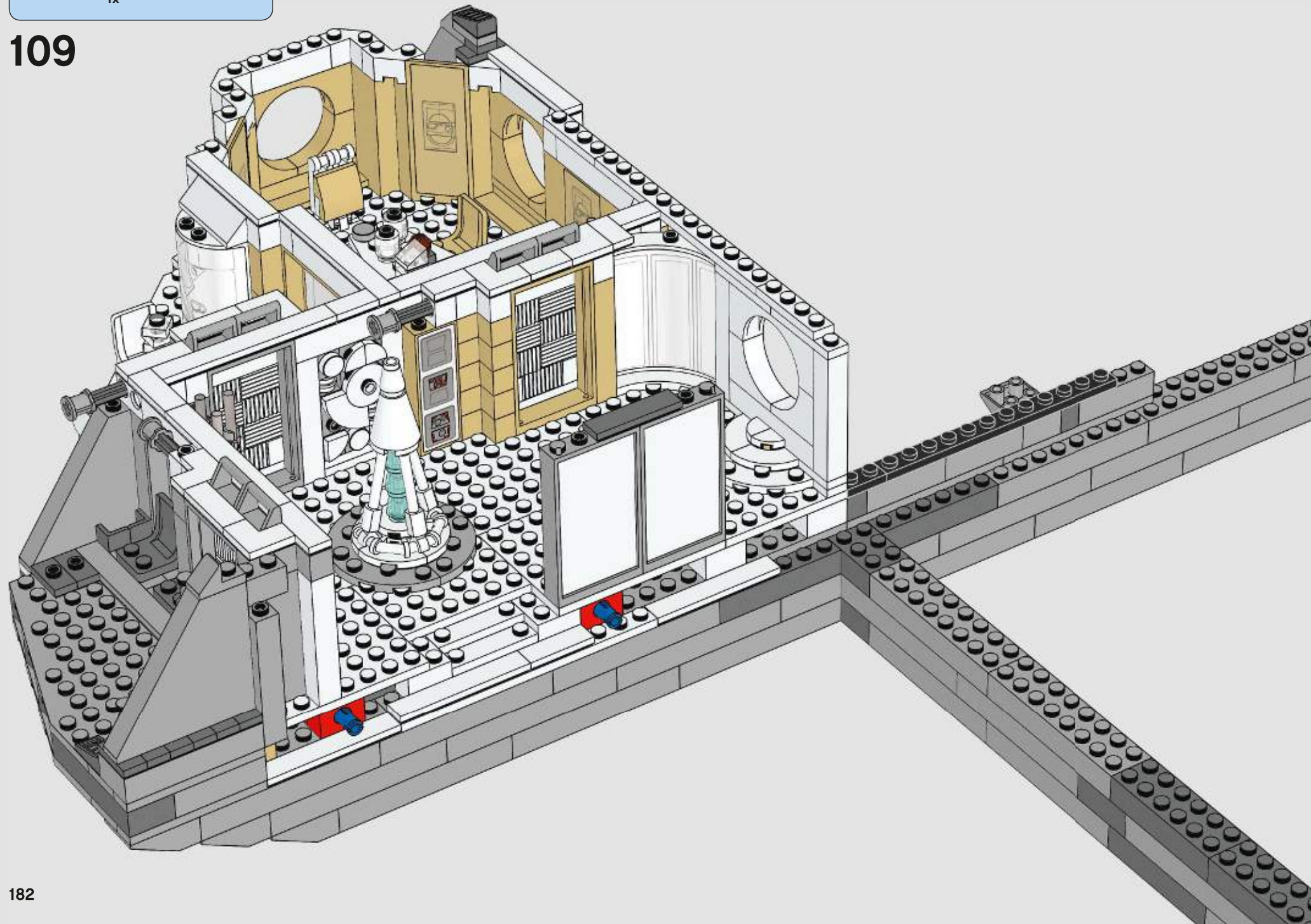

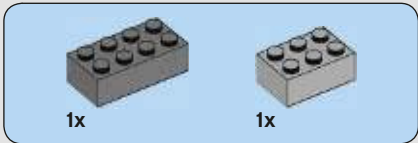
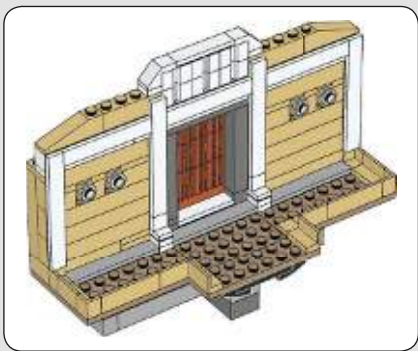

110

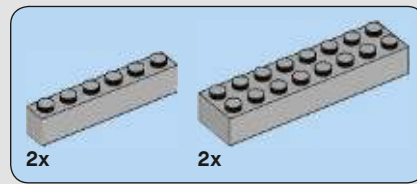
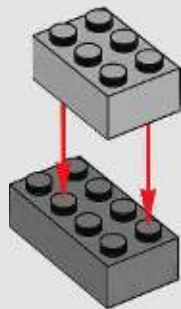

111

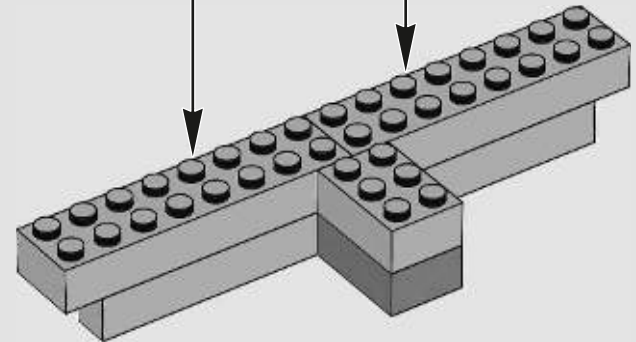
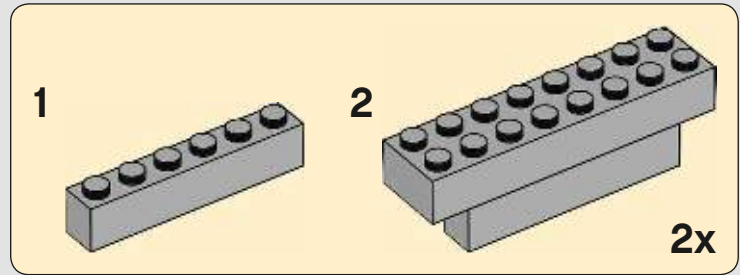

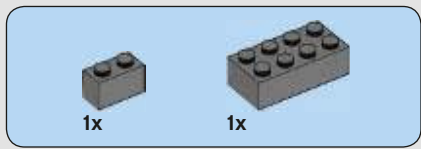

112

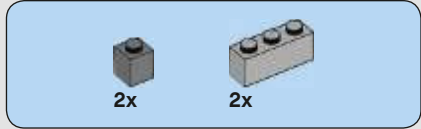
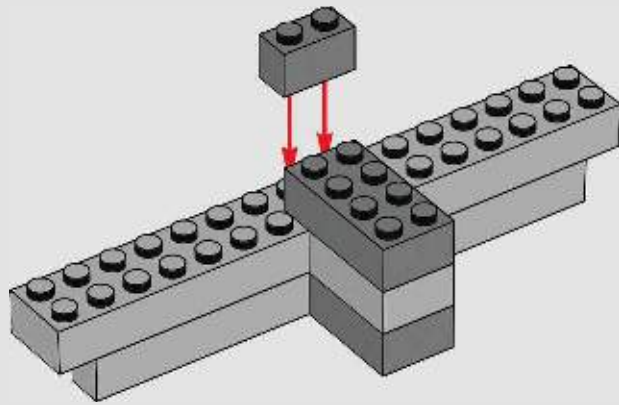

113

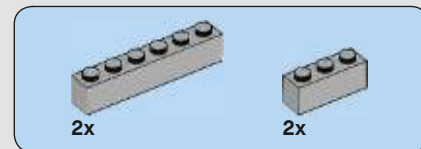
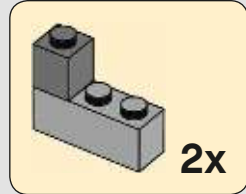
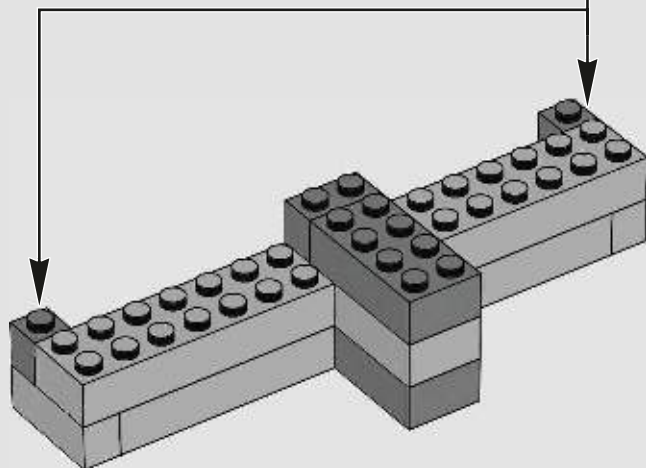

114

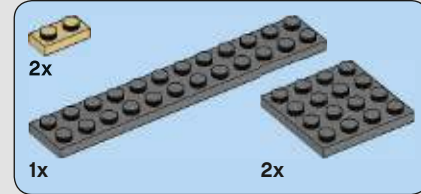
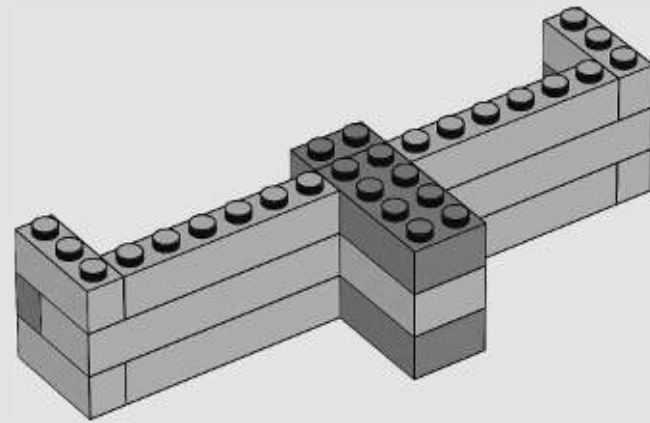

115

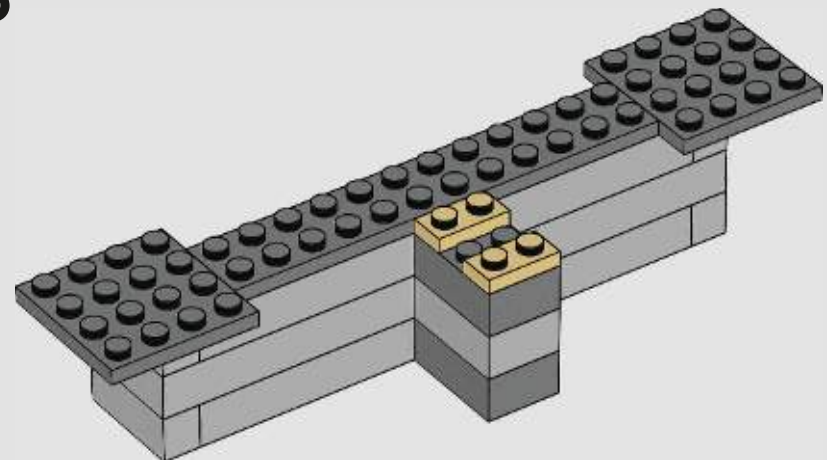

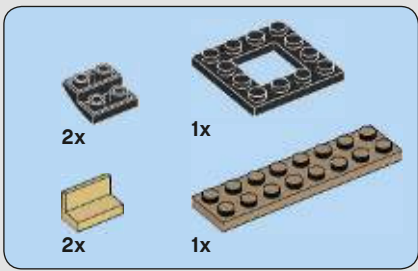

116

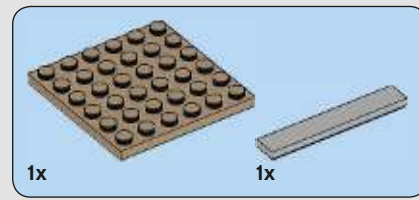
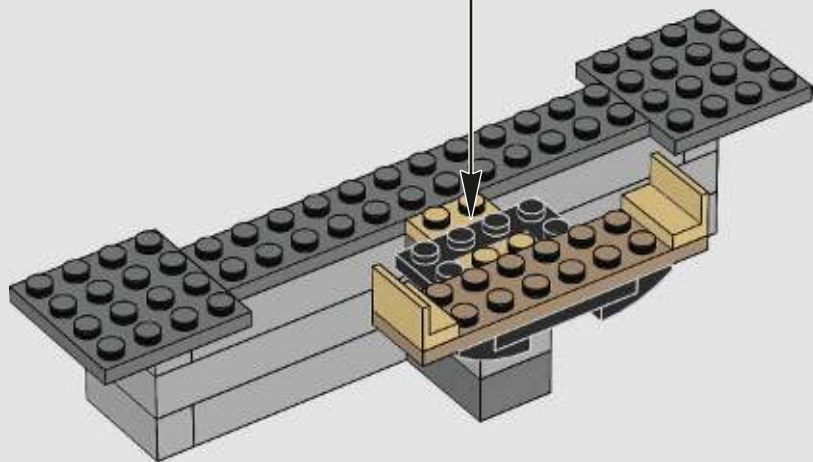
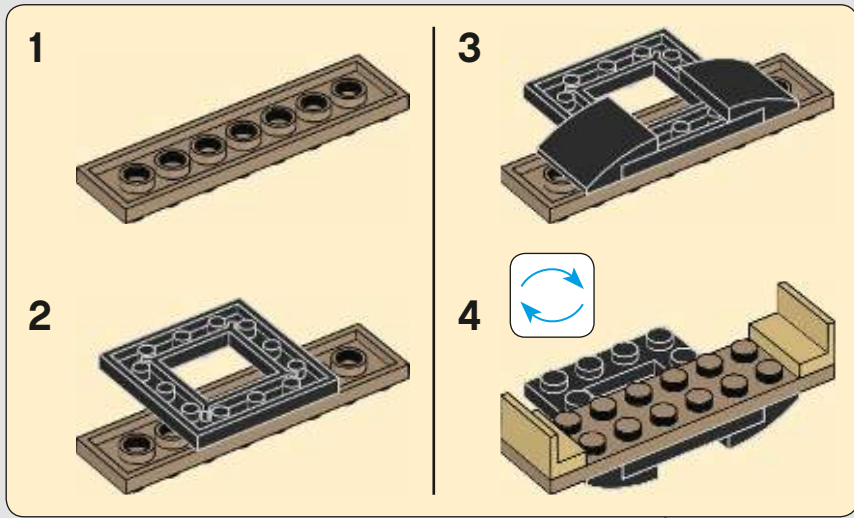

117

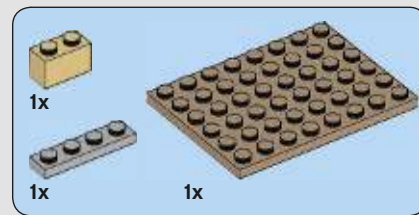
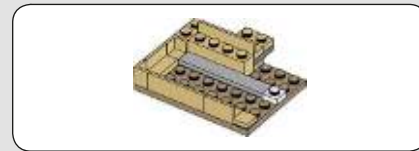
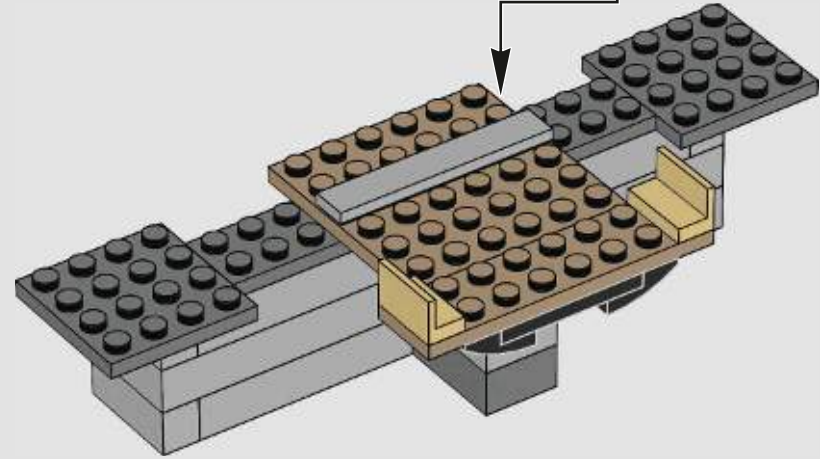
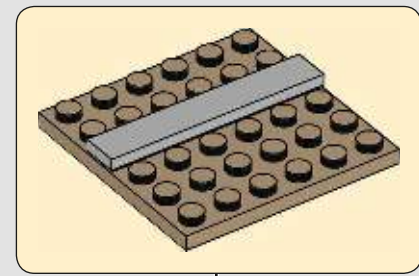

118

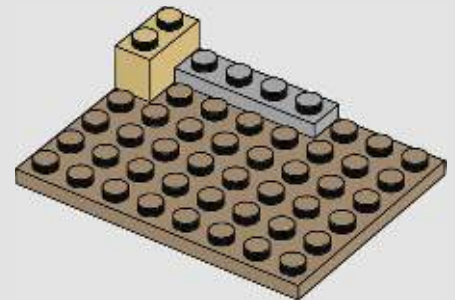

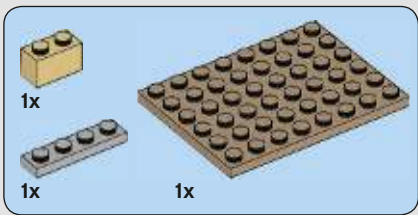

123

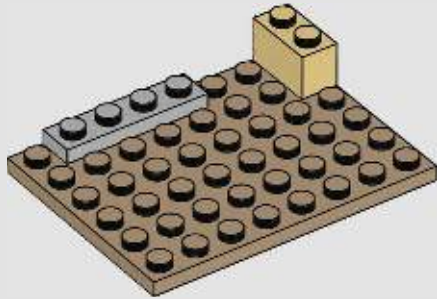

124

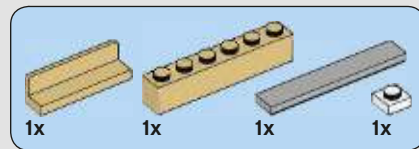
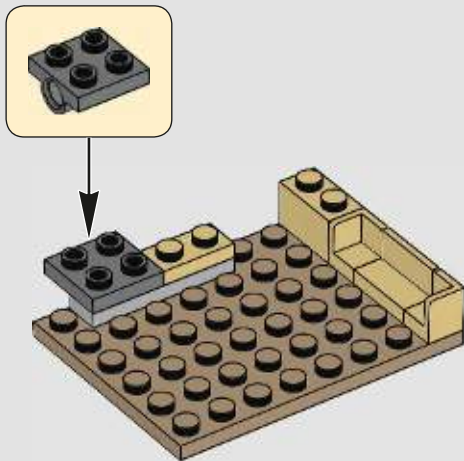

125

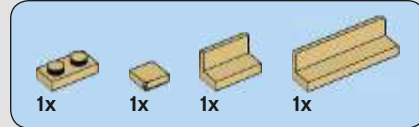
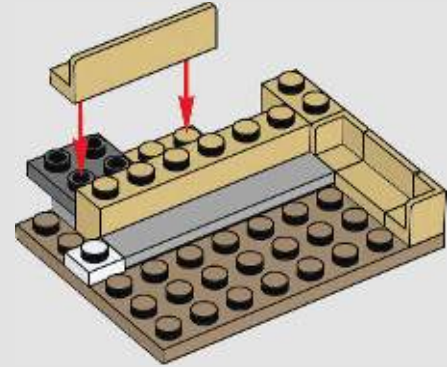

126

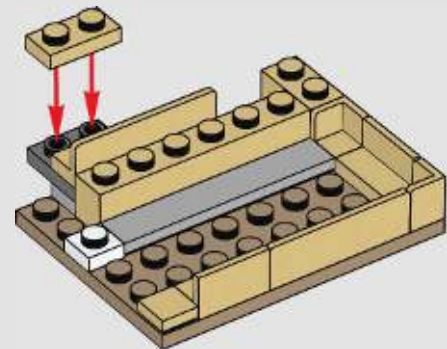

127

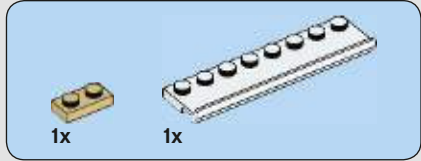
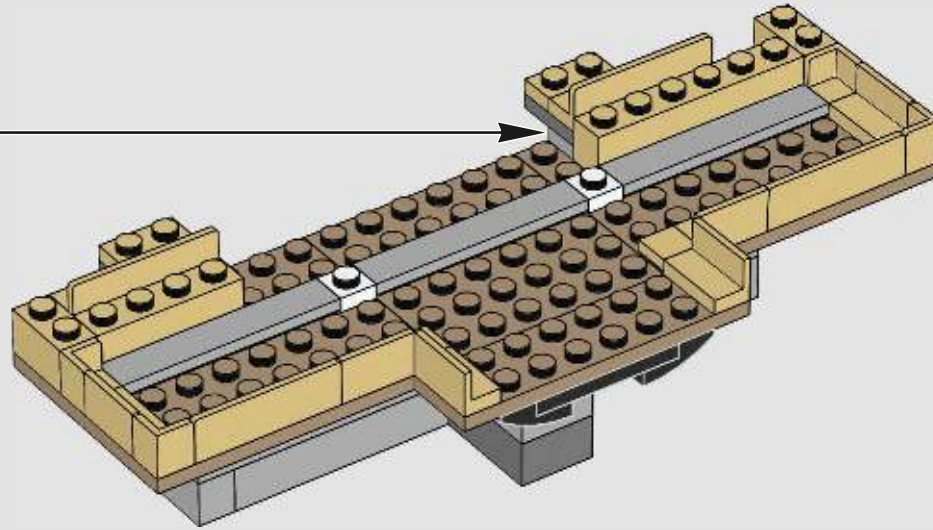

128

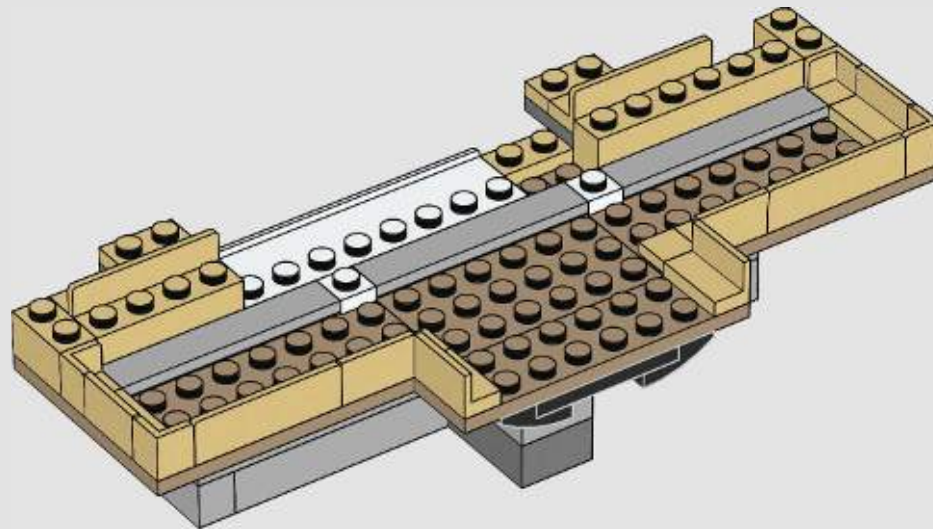



129

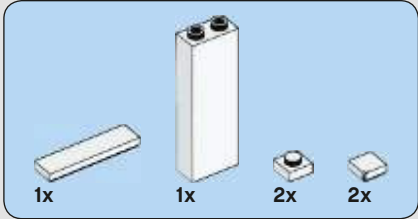
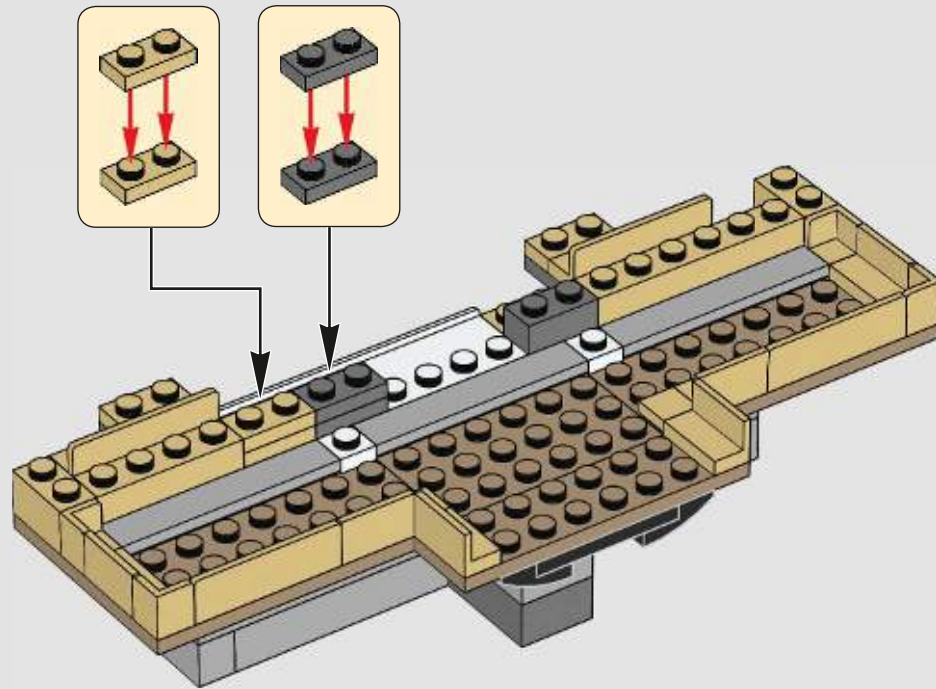

130

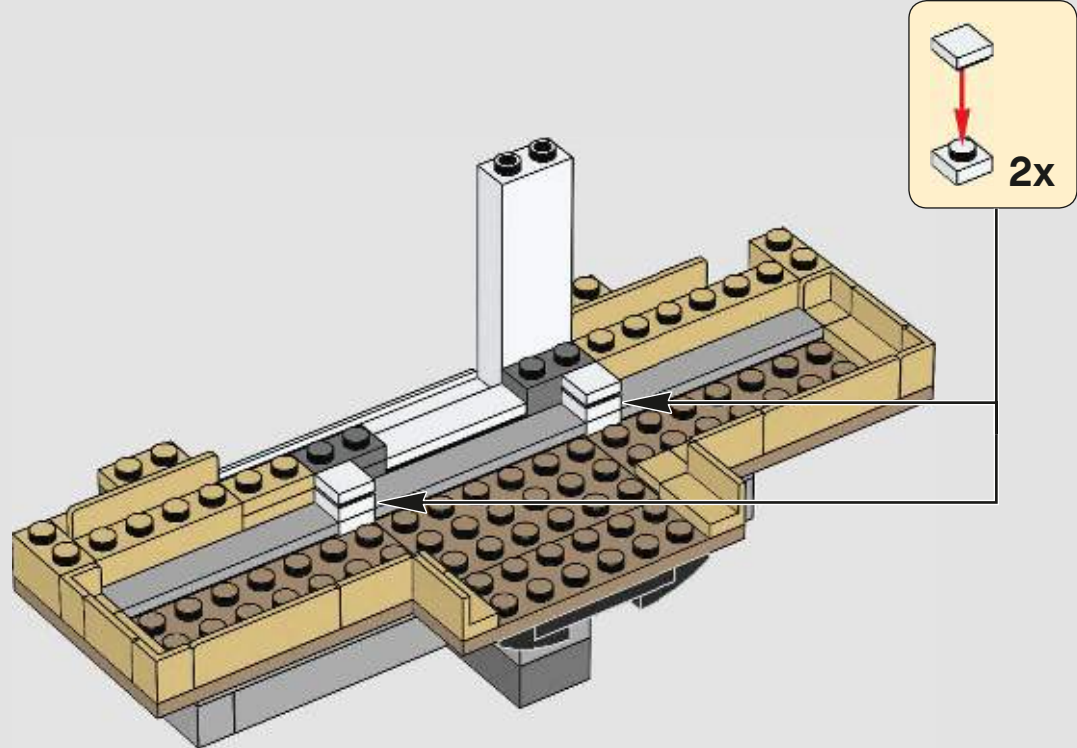

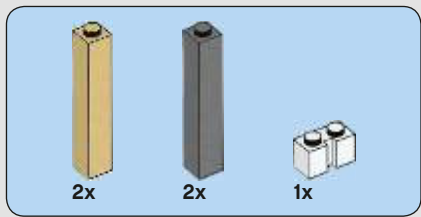

131

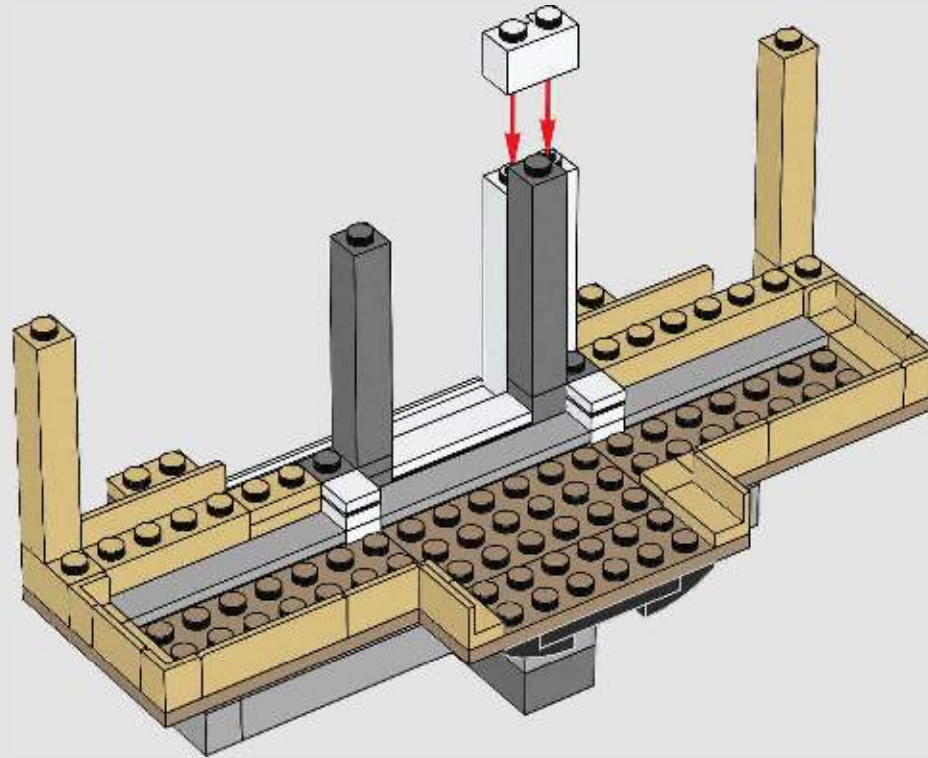

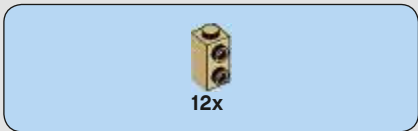

132

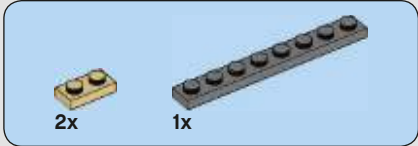
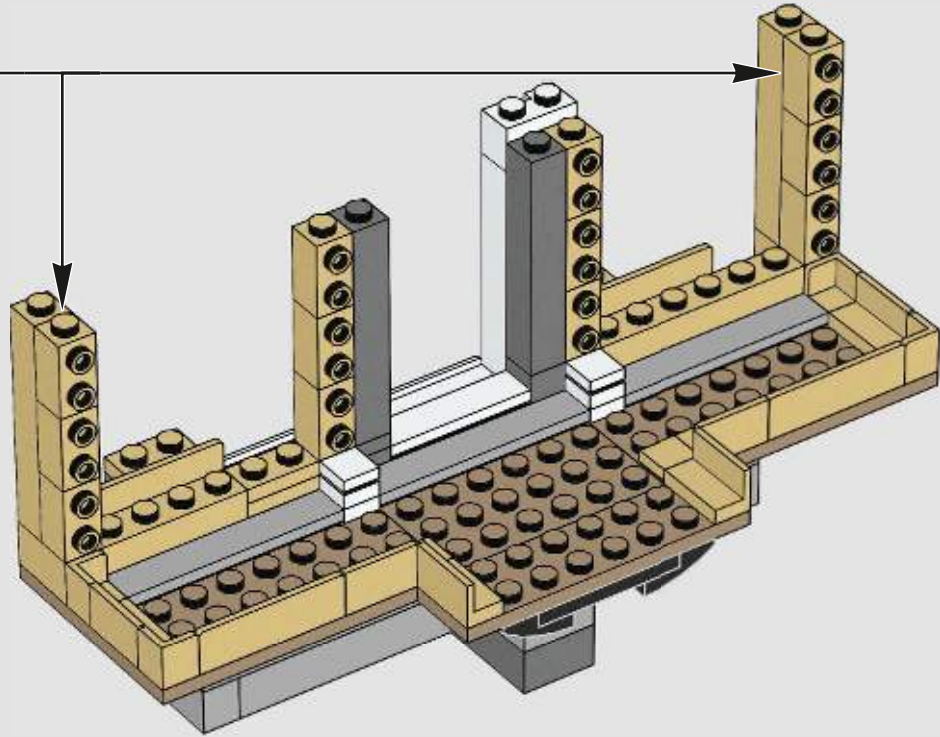
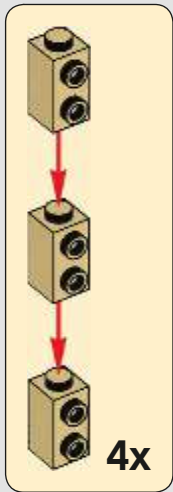

133

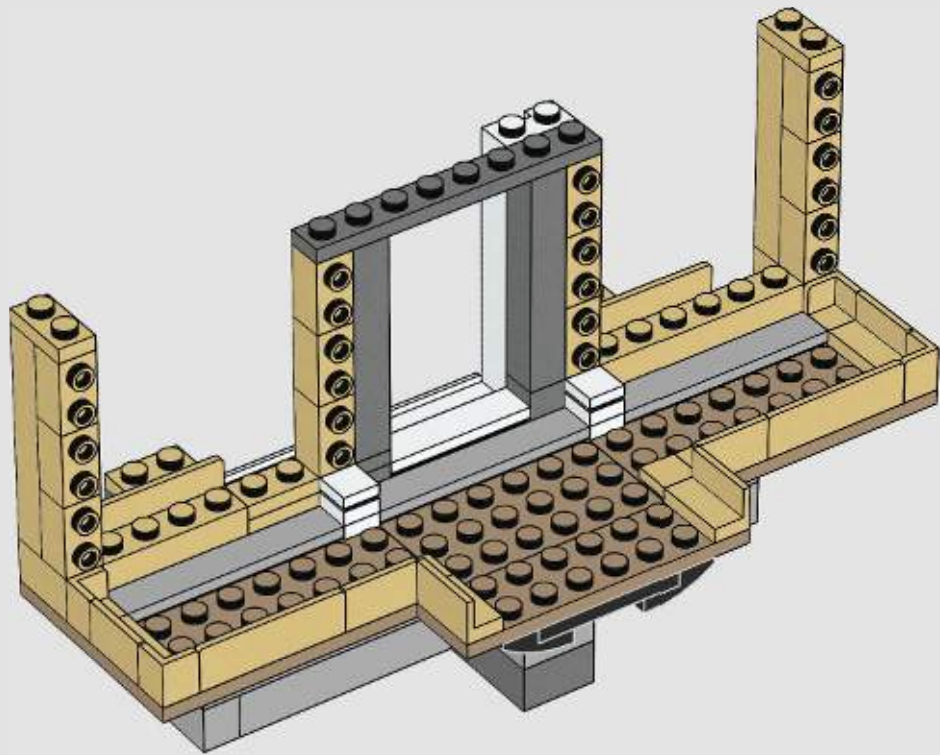

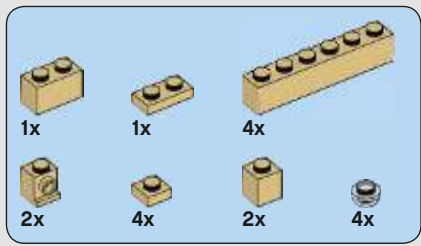

134

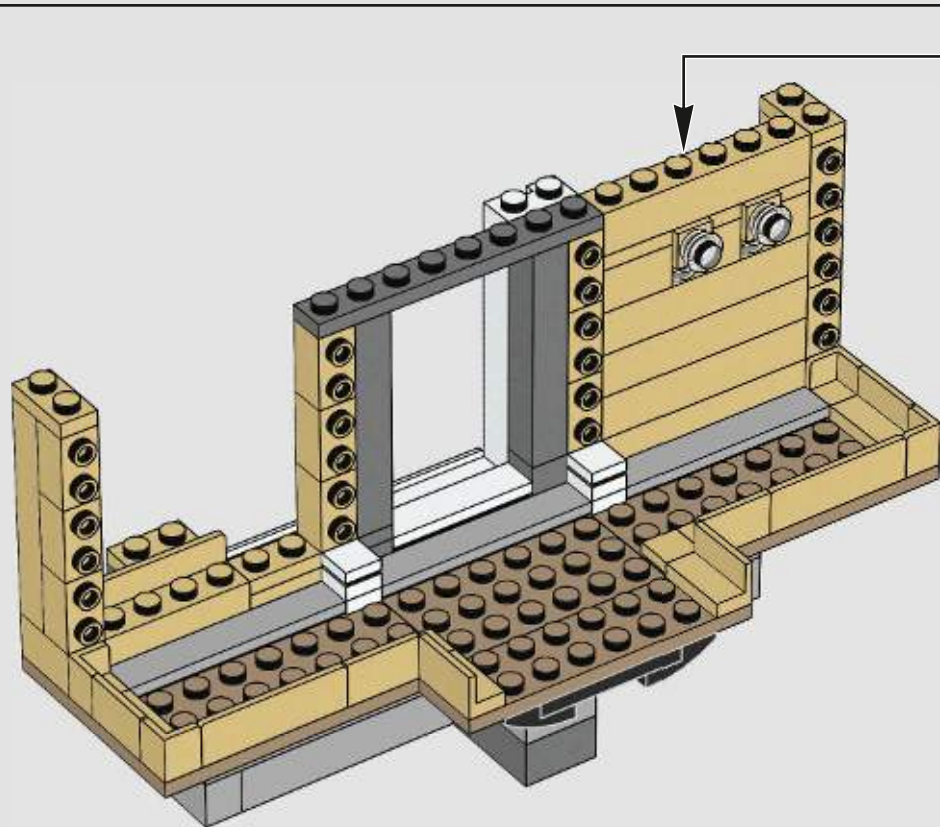
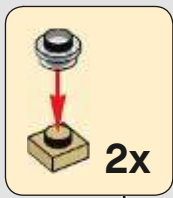
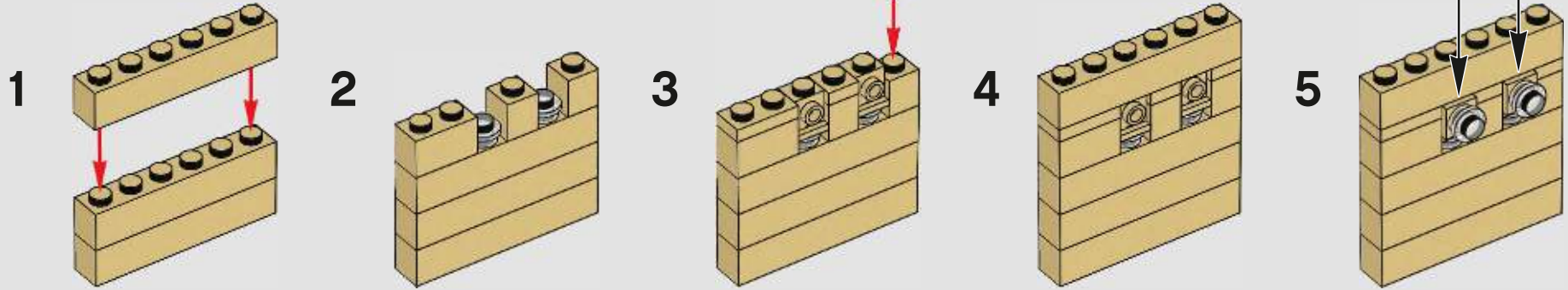

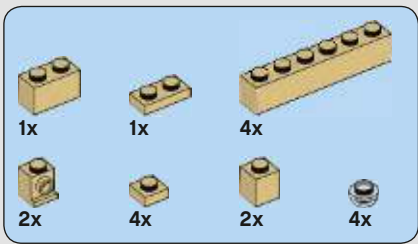

135

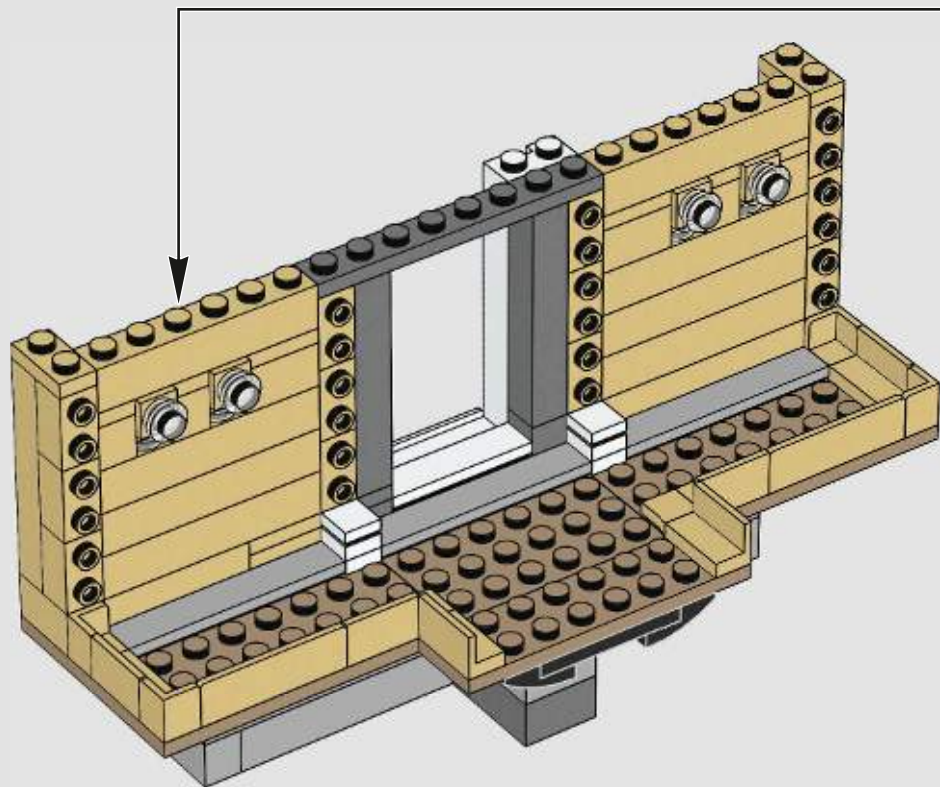
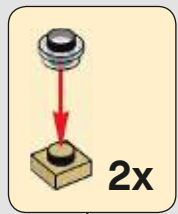
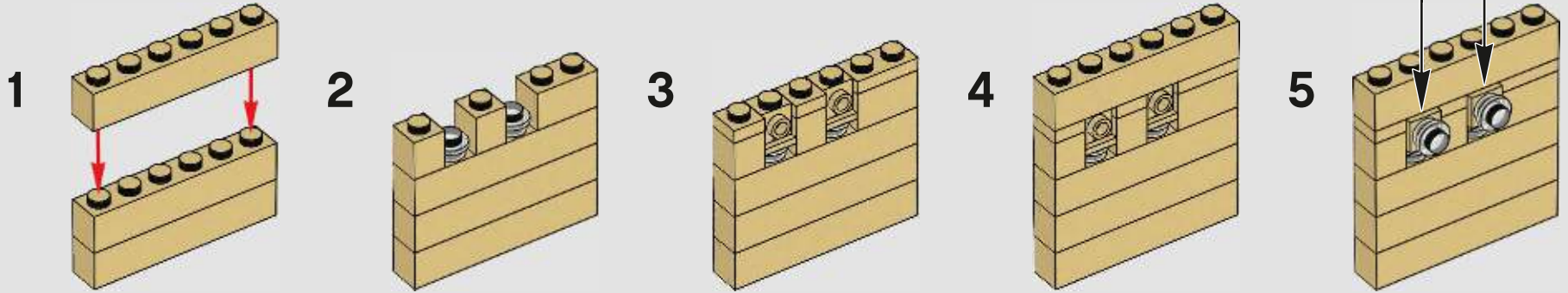

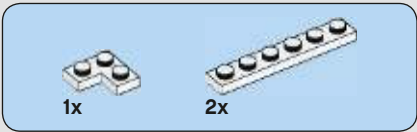

136

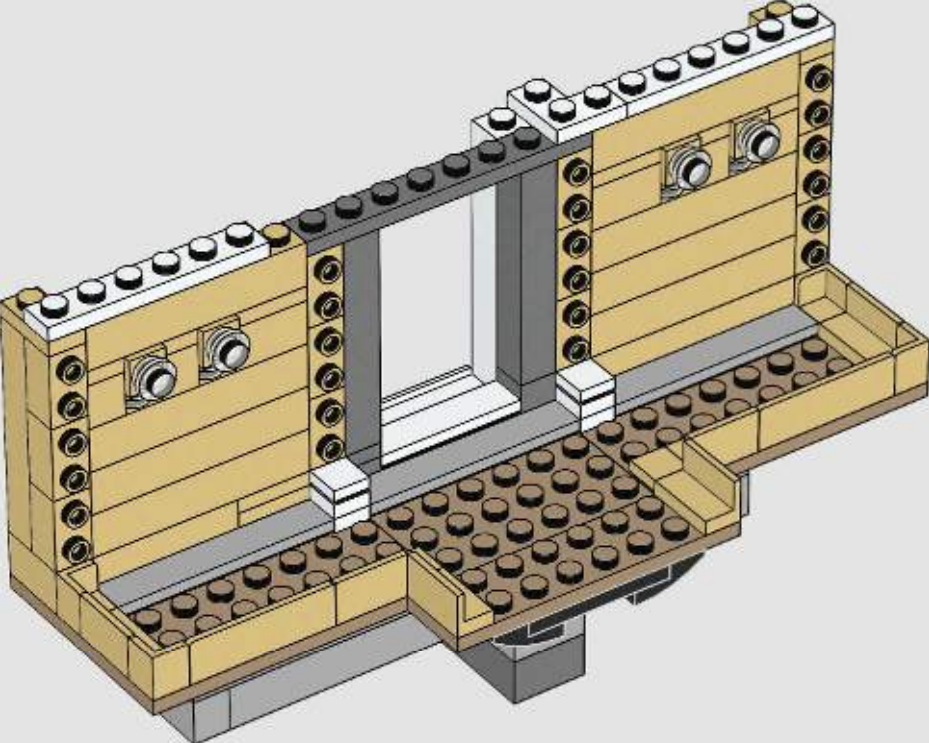

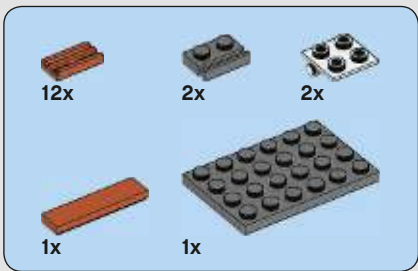

137

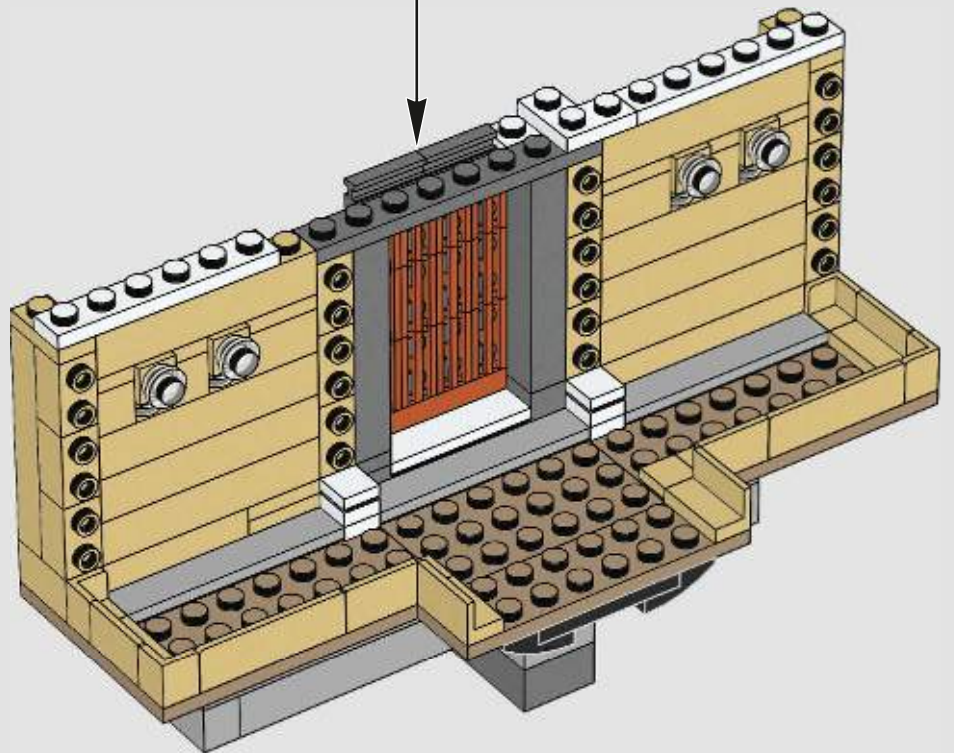
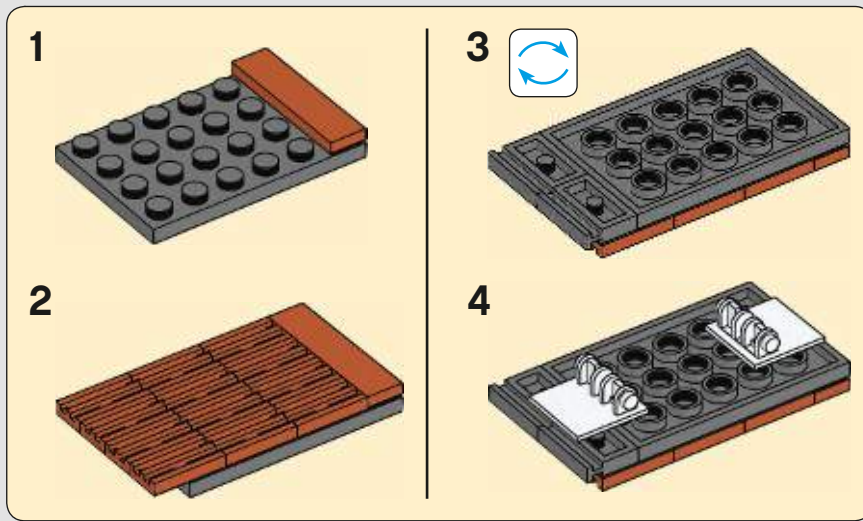

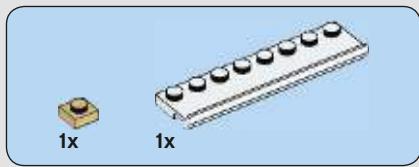

138

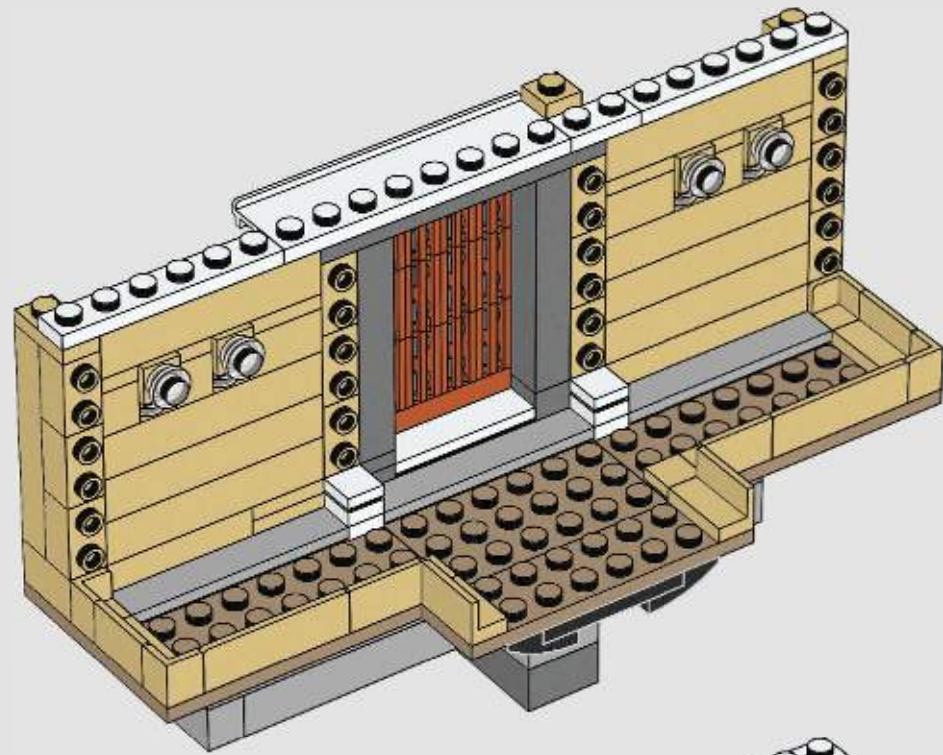

139

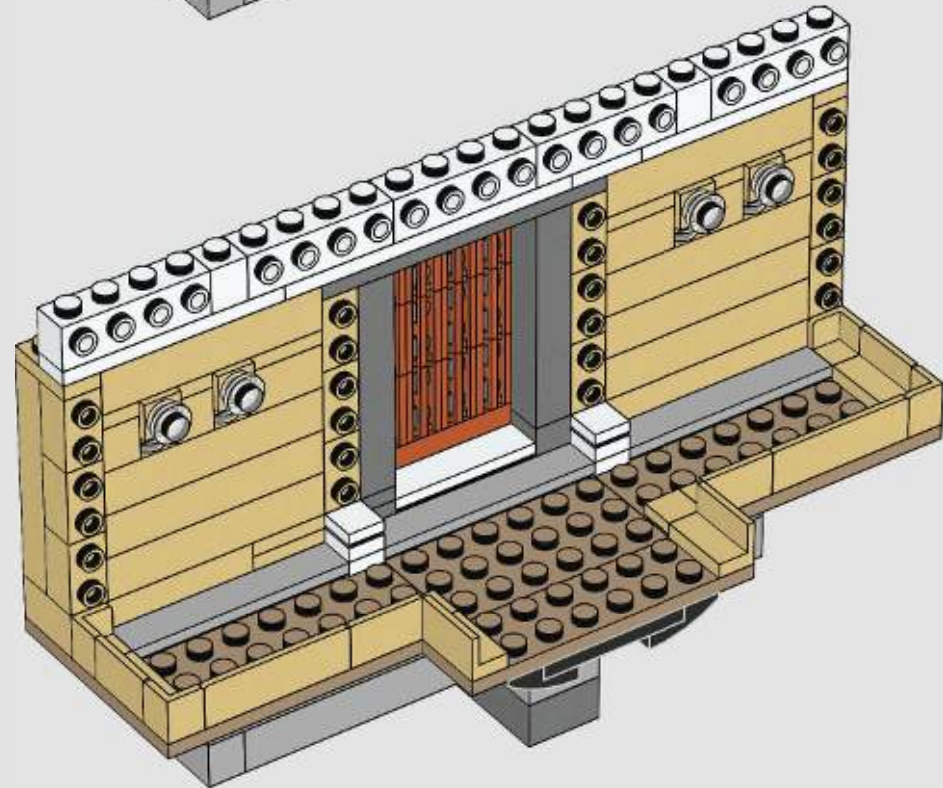

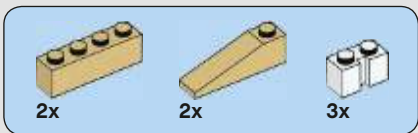

140

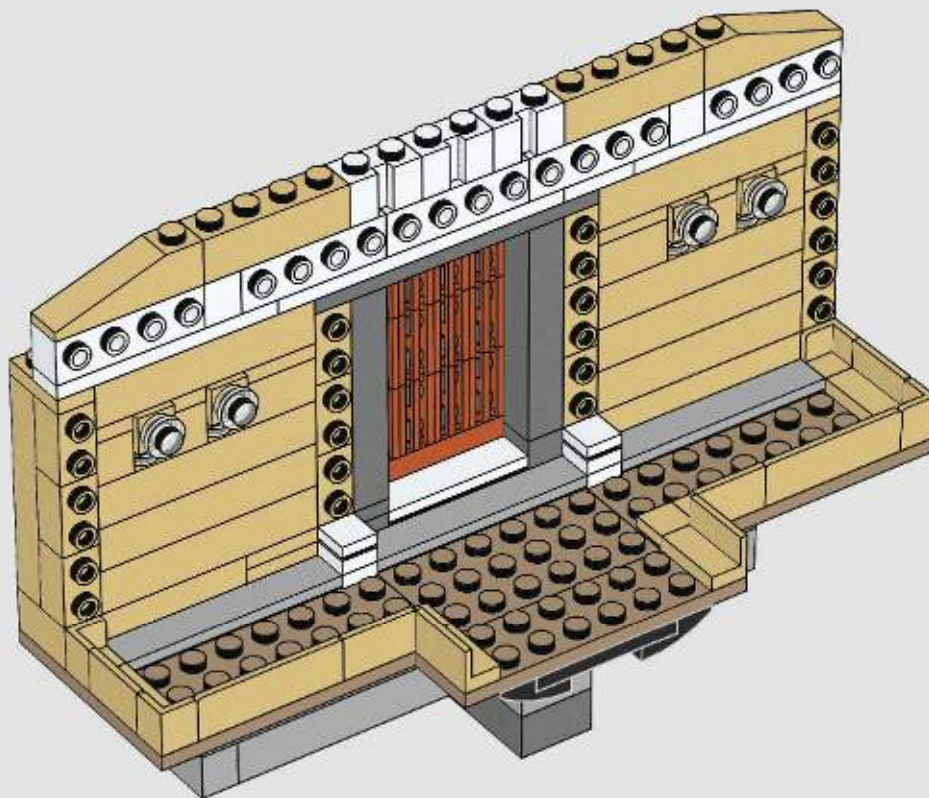



2x



3x

141

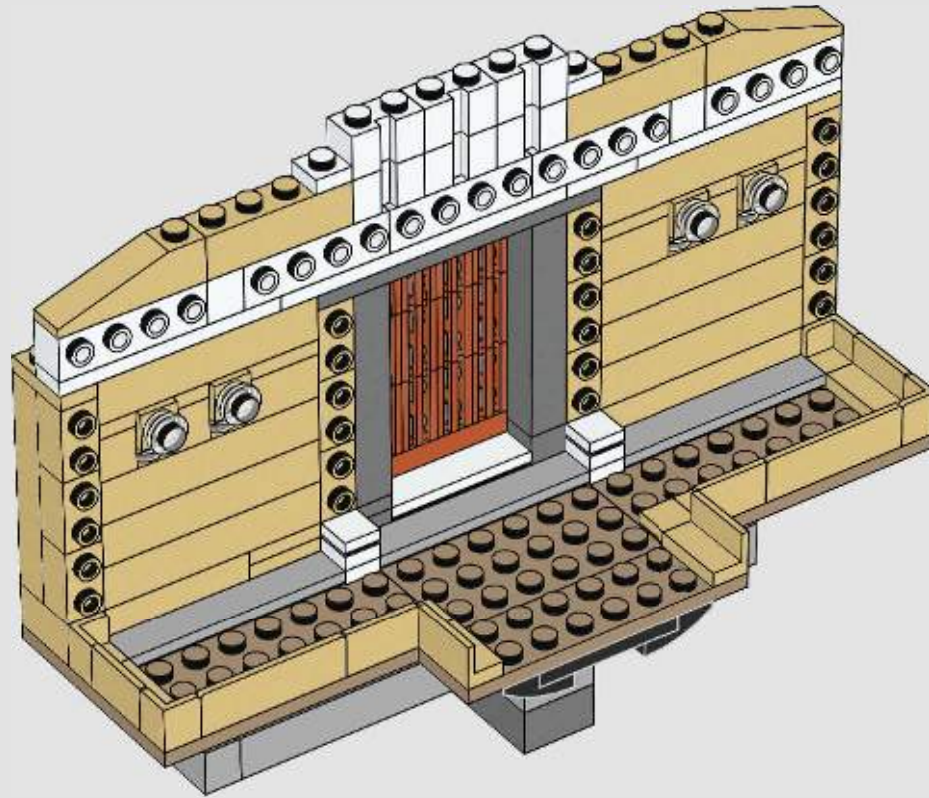



142

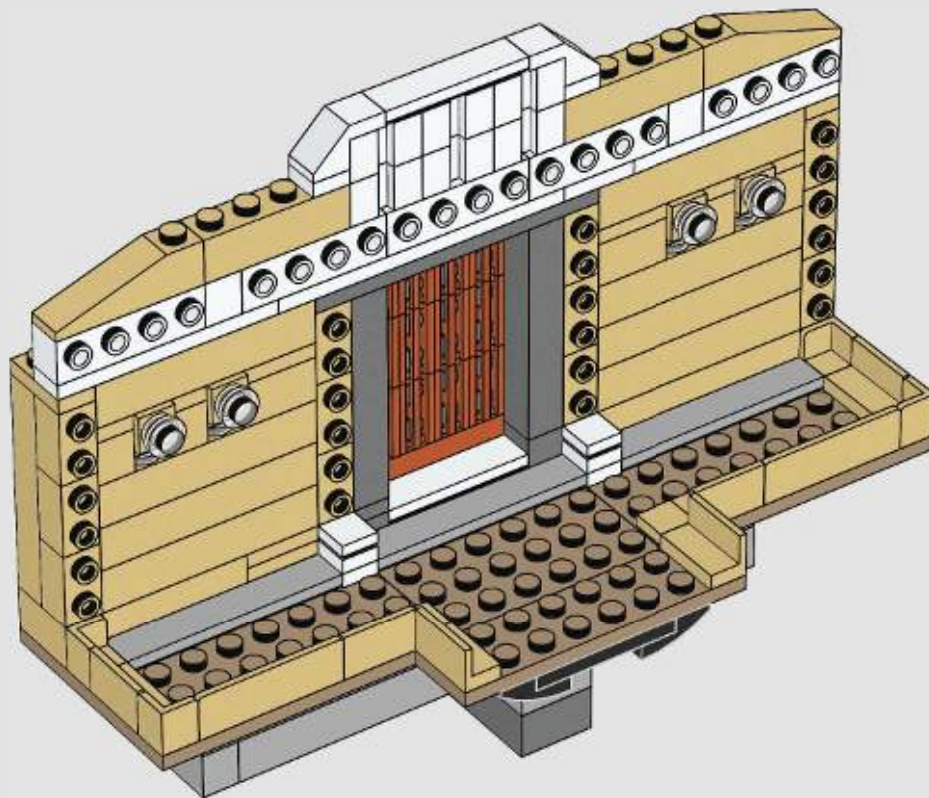

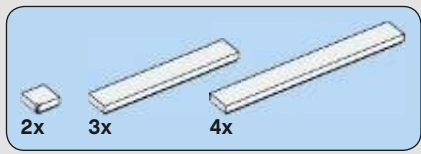

143

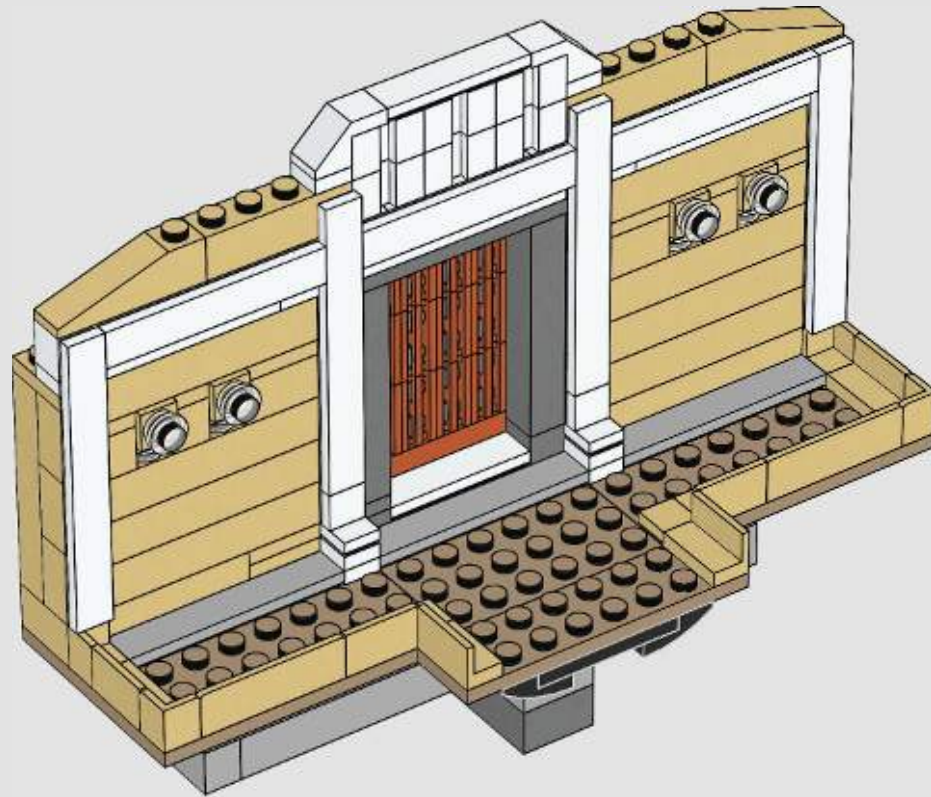

144



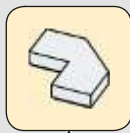
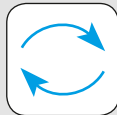

145

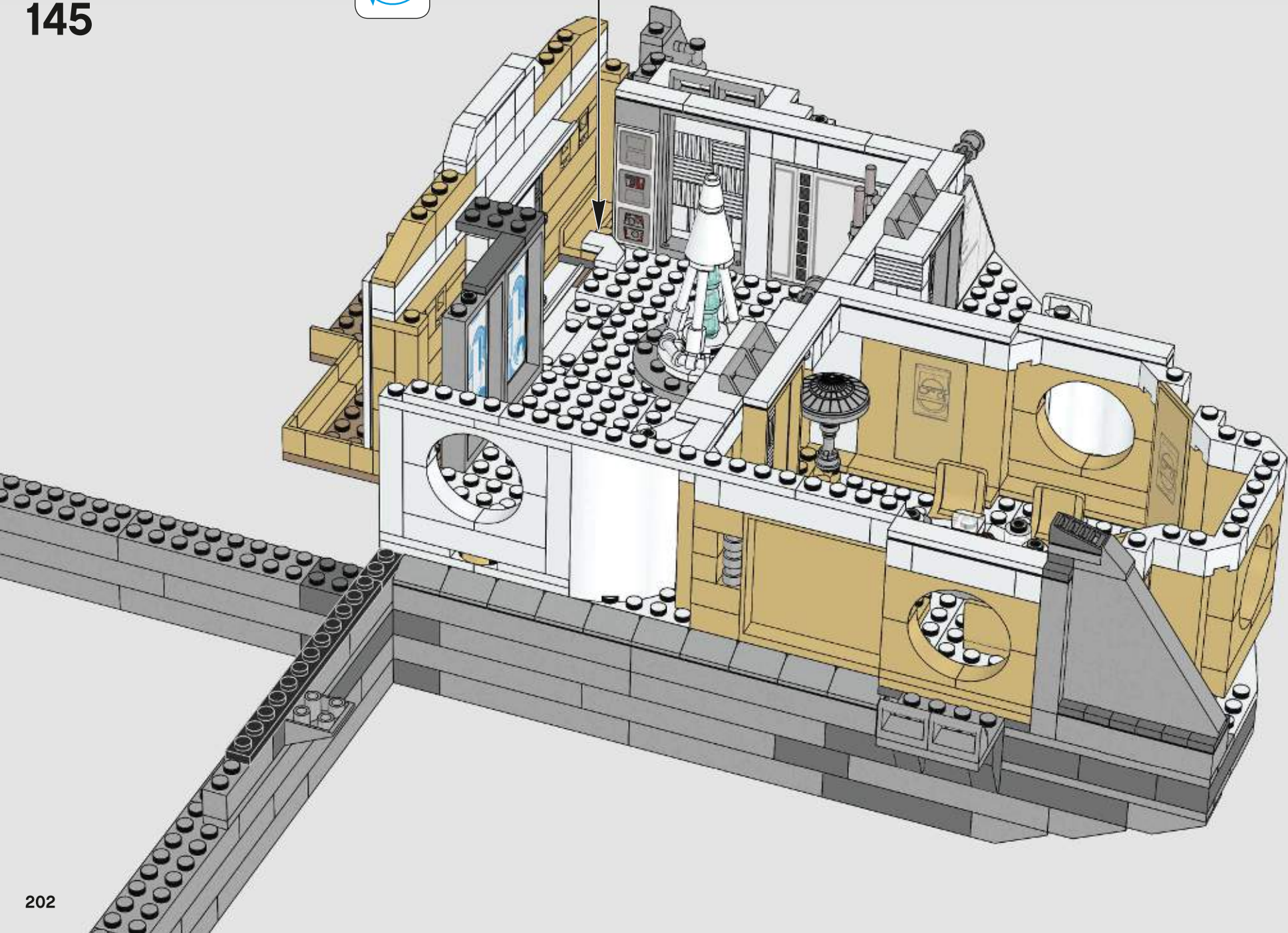

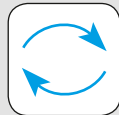

146

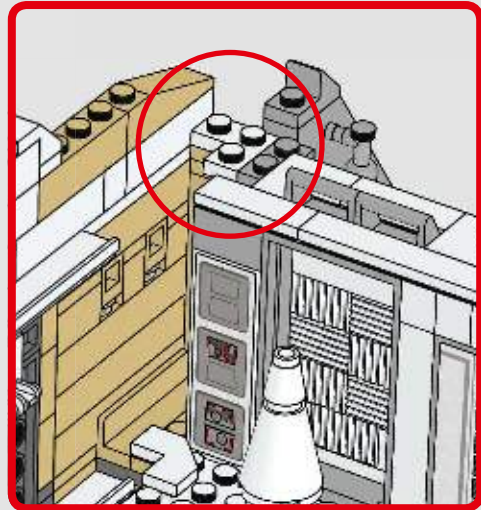
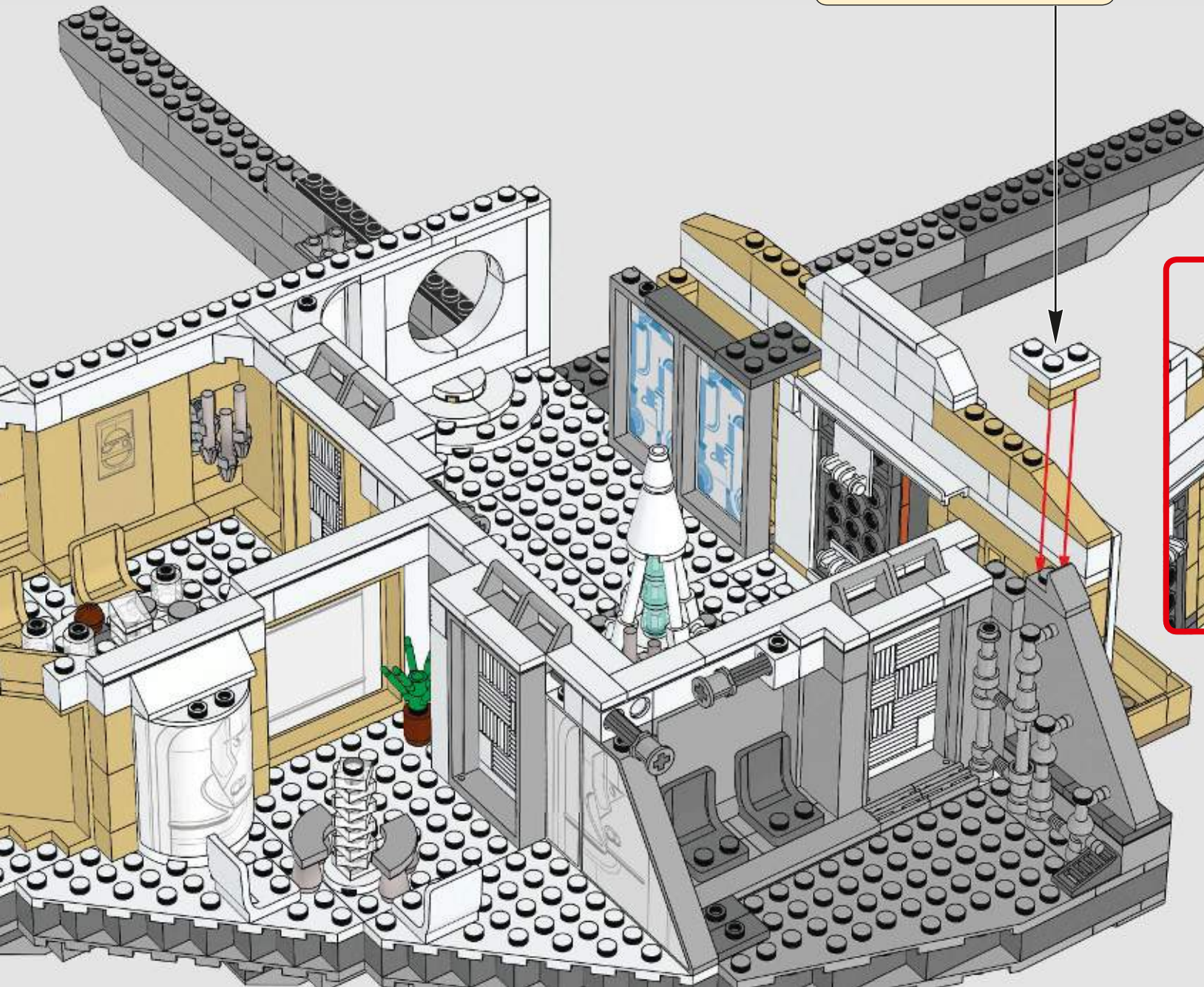
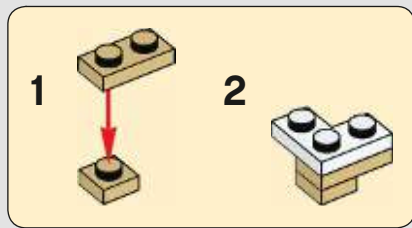

2x

1x

147

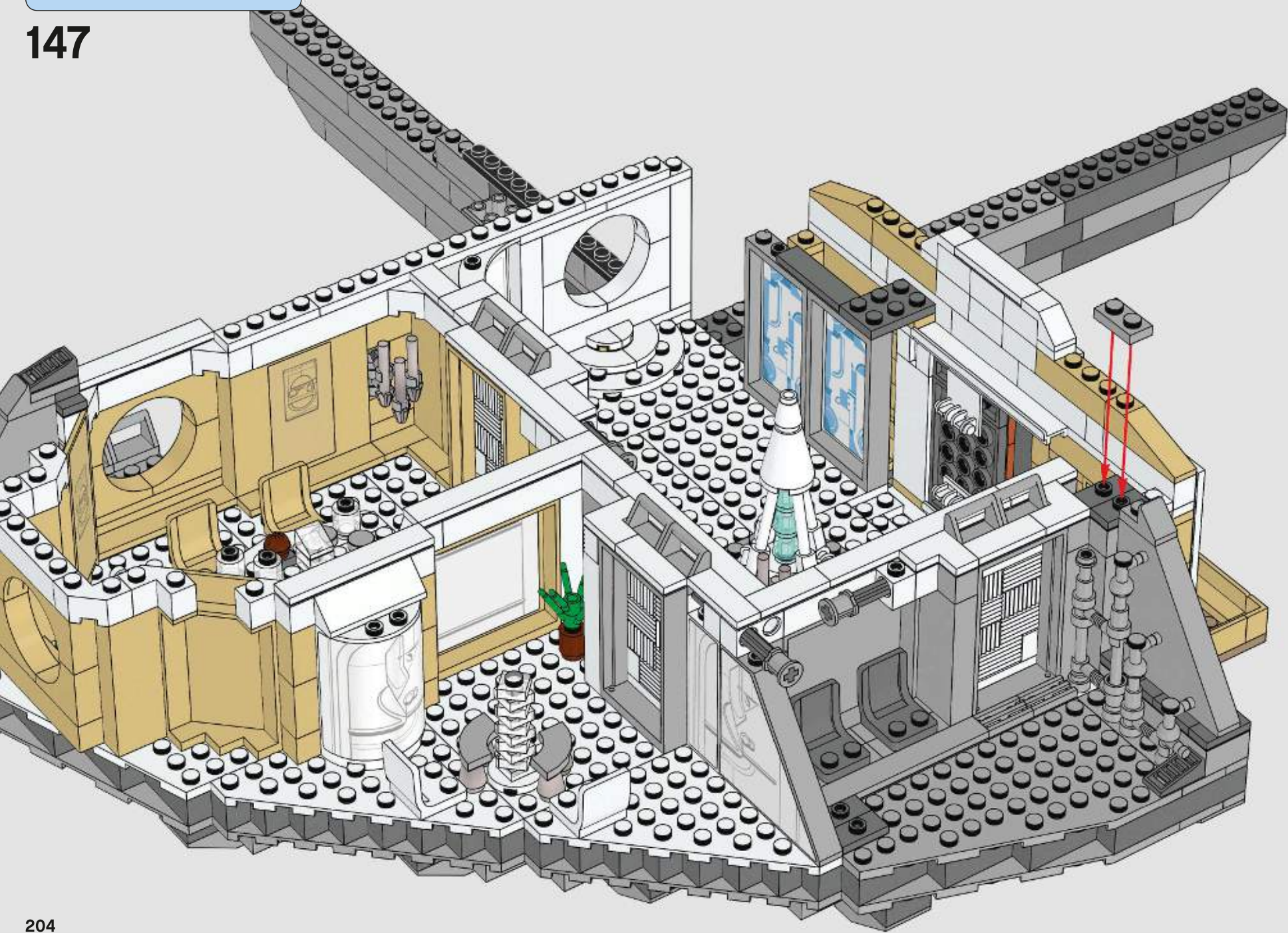



148

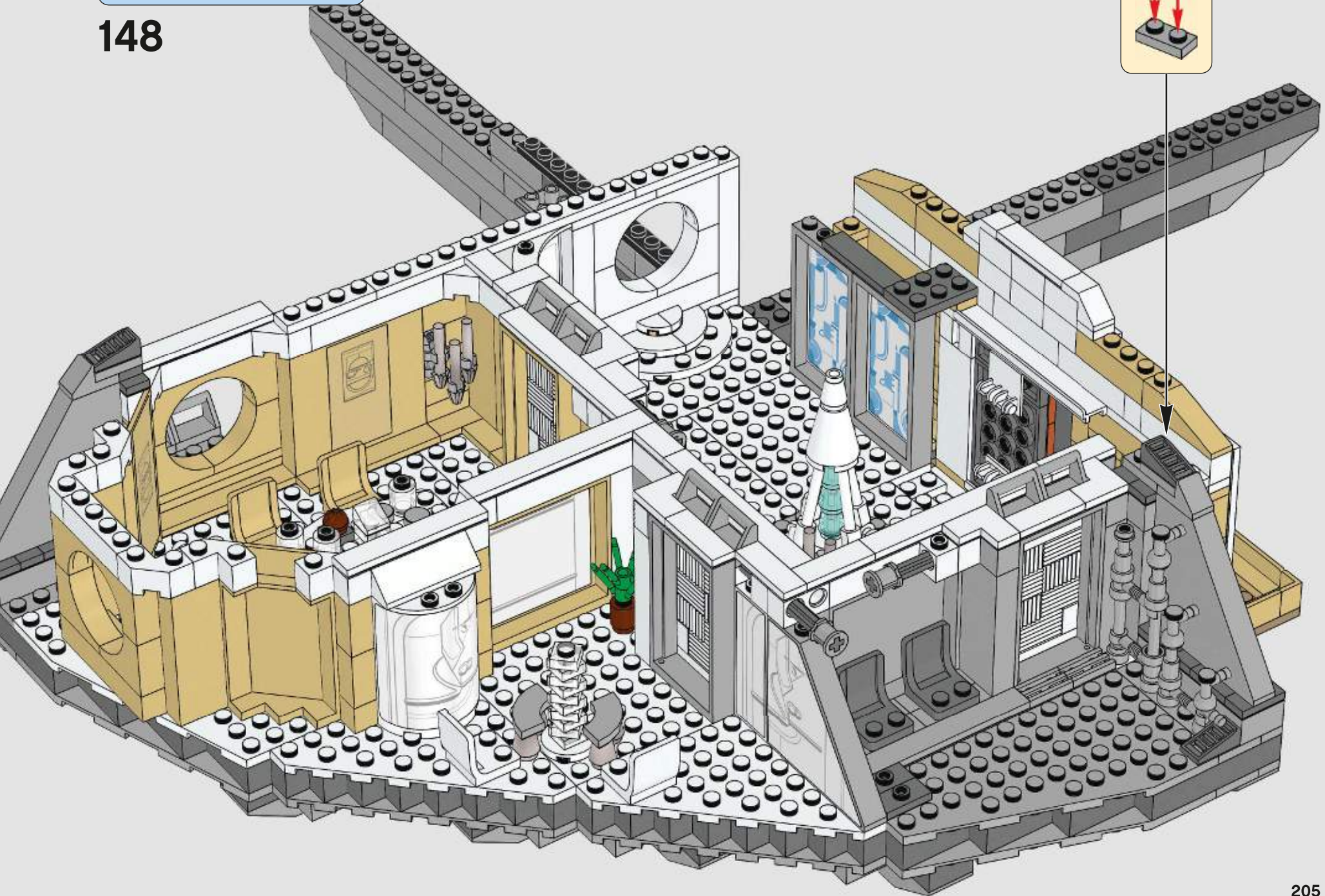
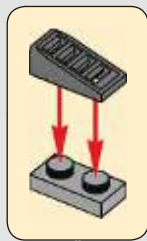

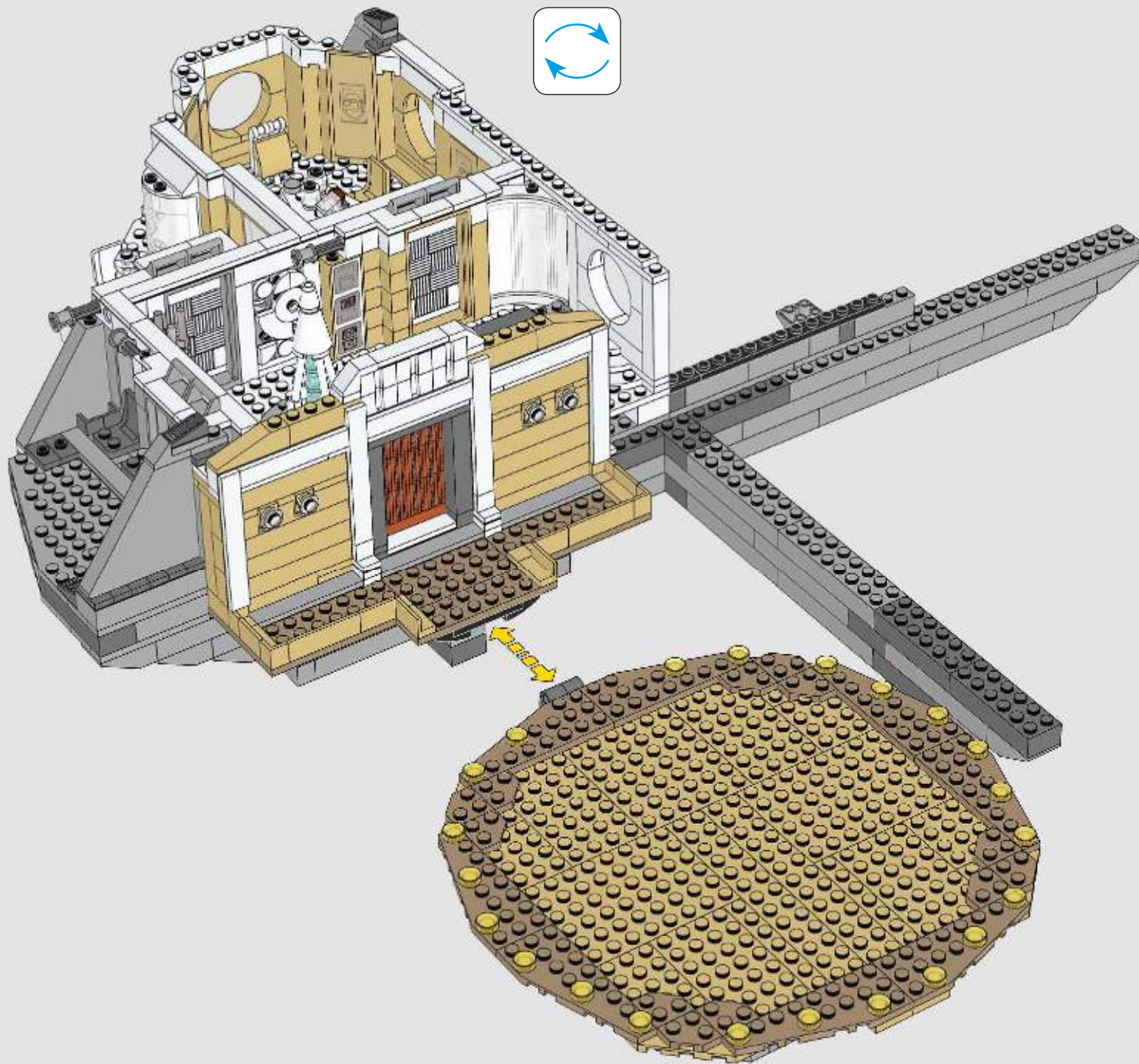

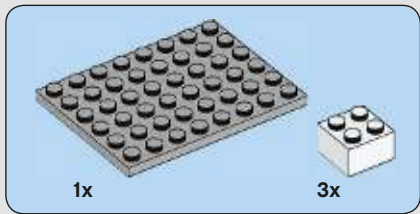
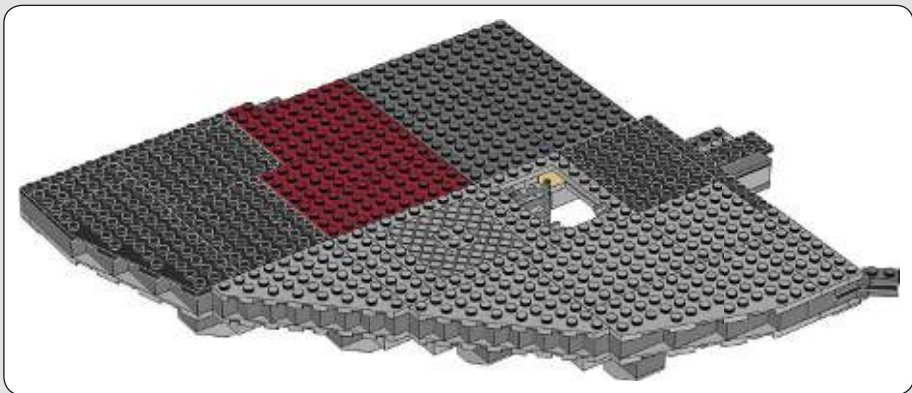
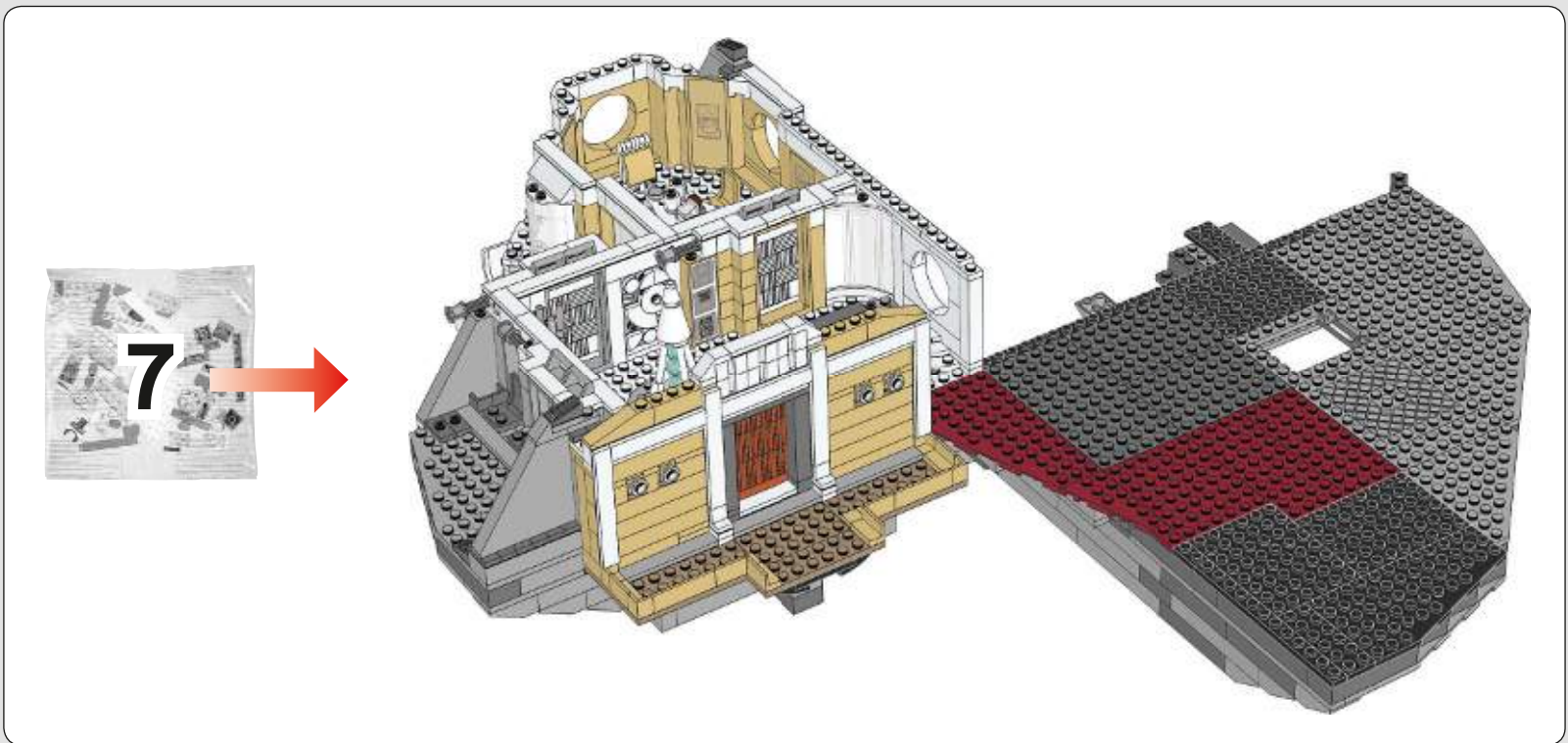

149

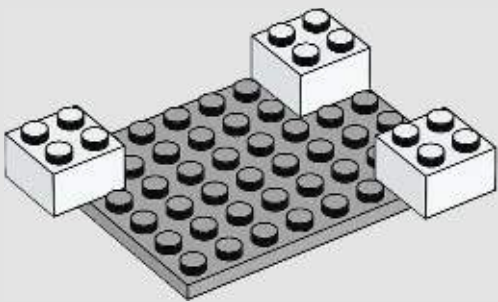

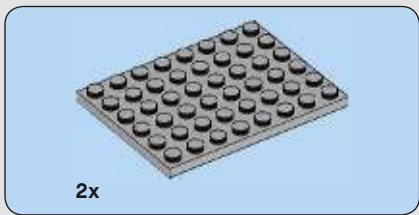

150

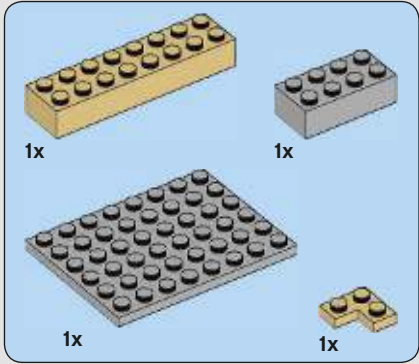
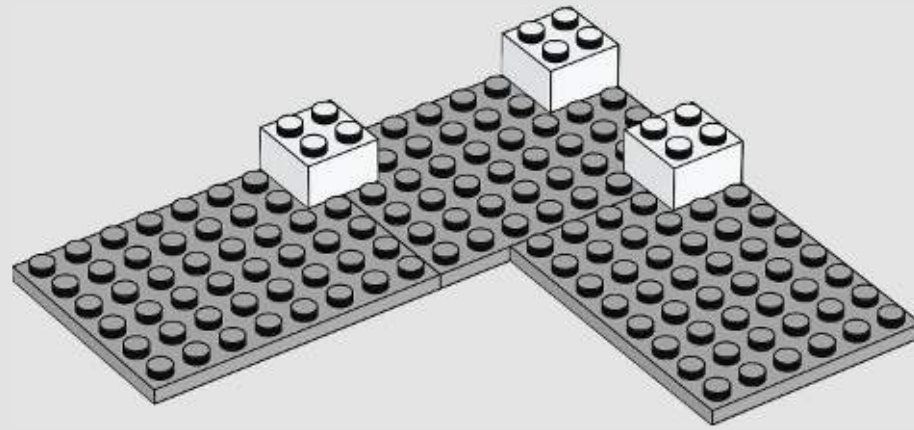

151

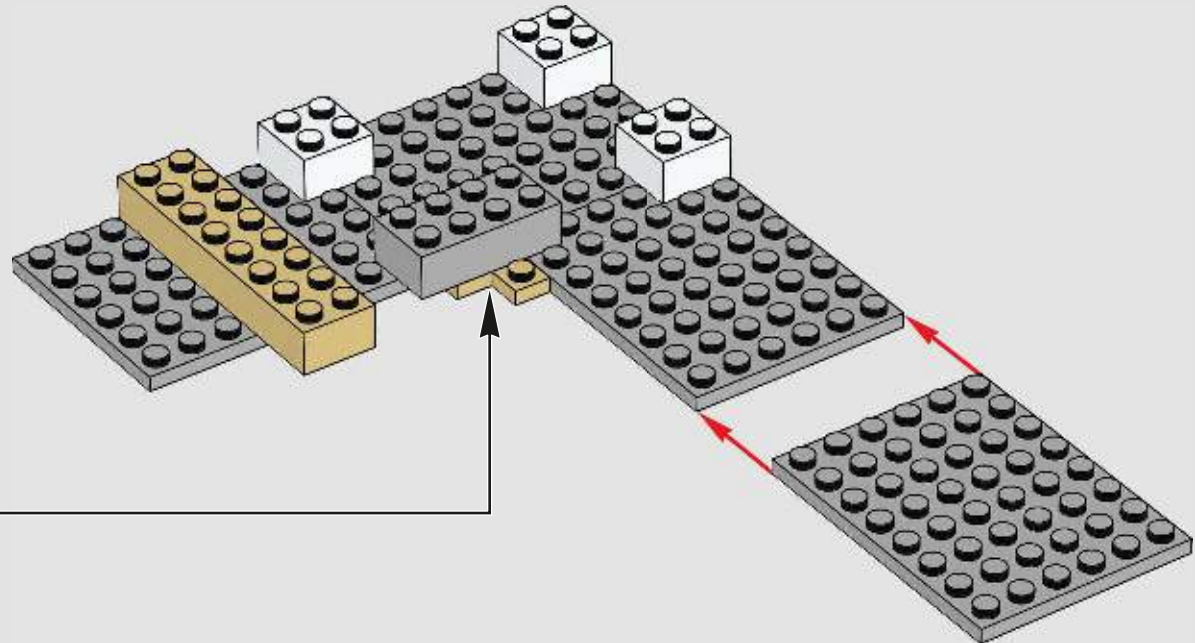

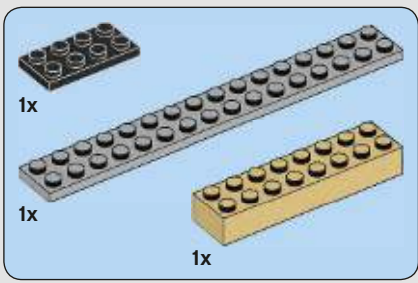

152

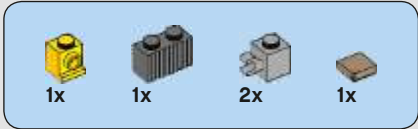
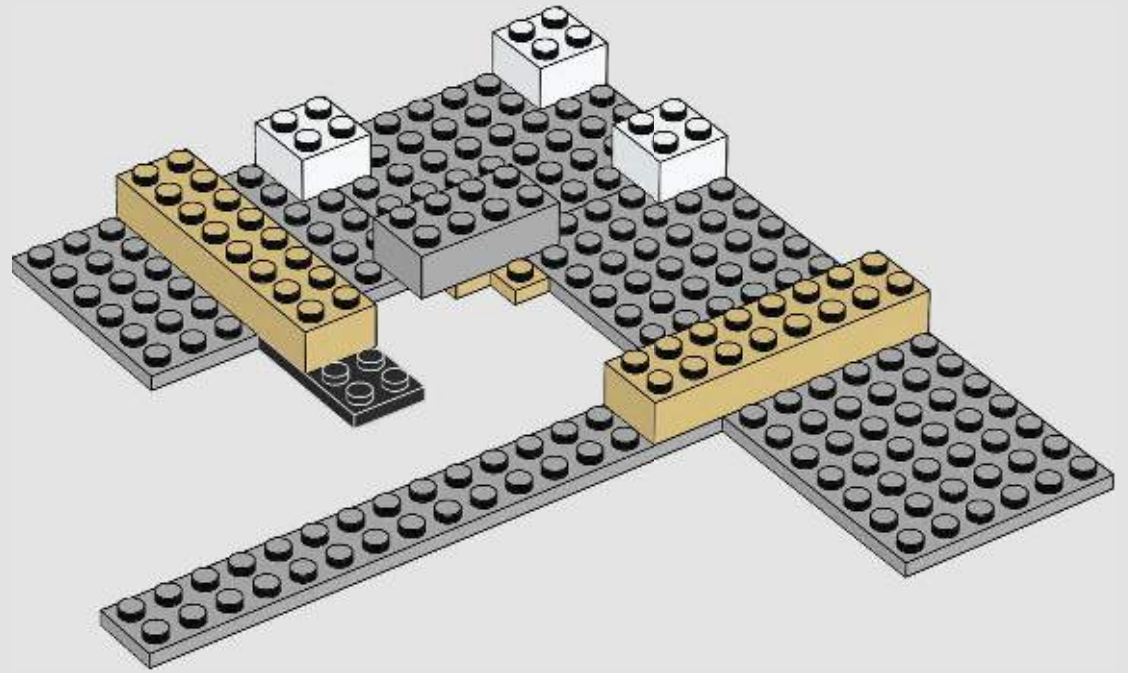

153

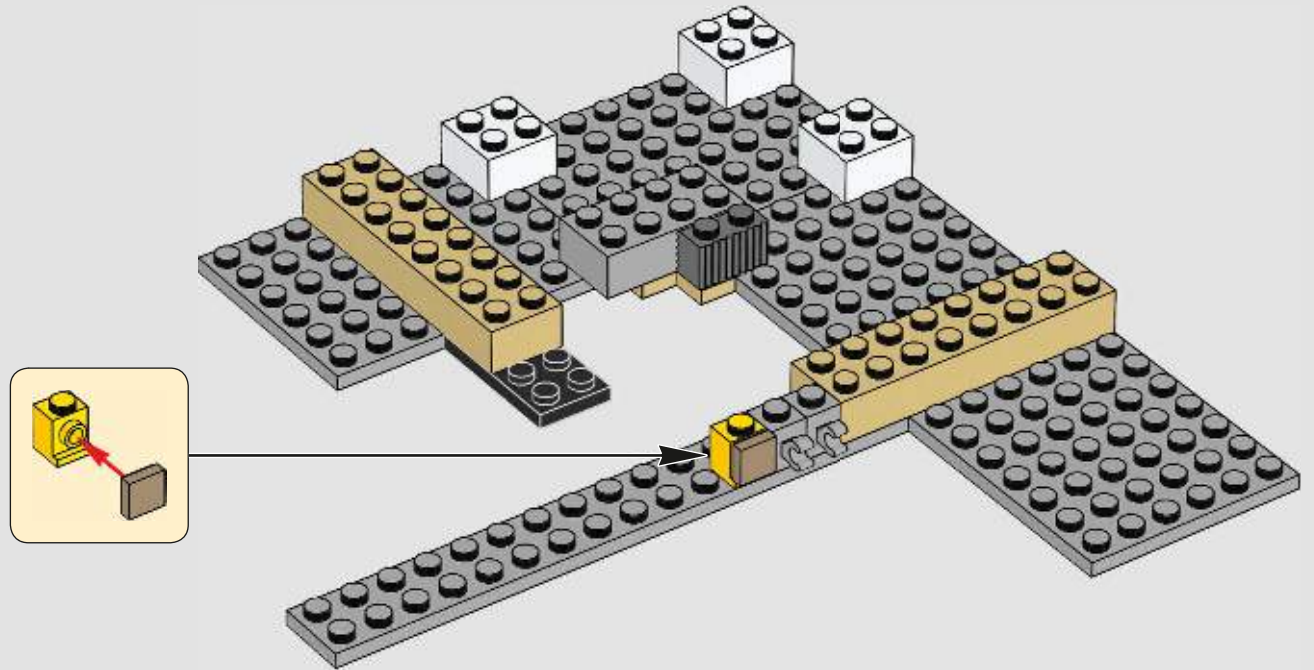

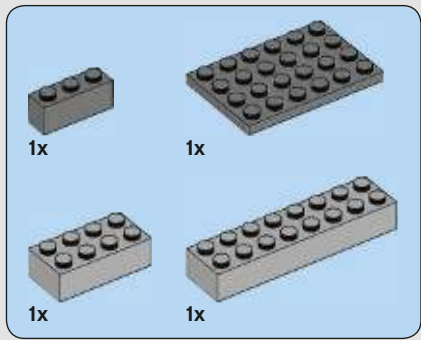

154

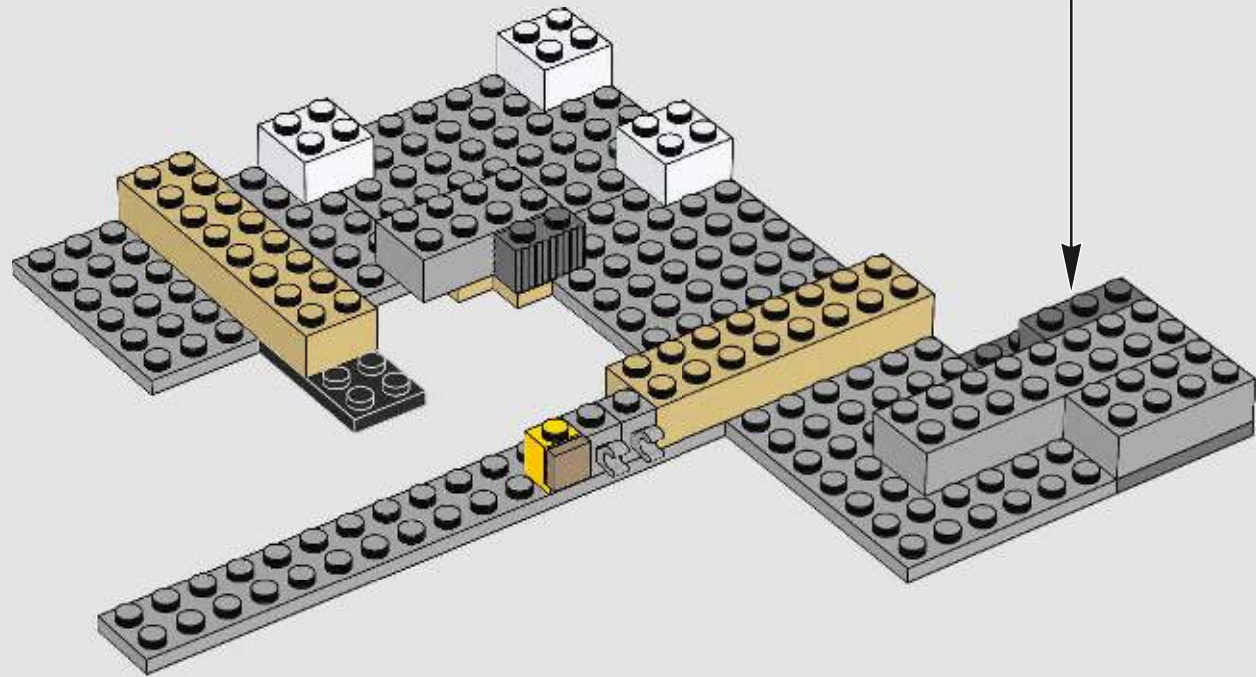
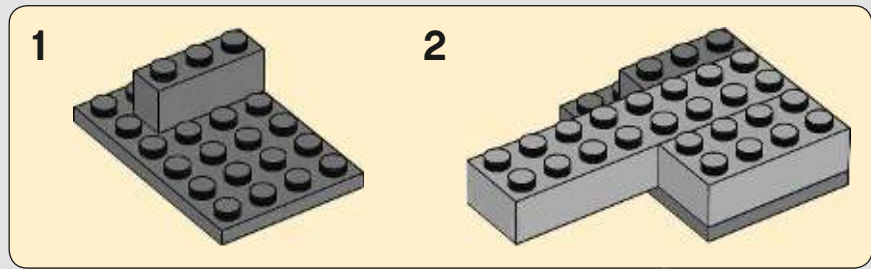

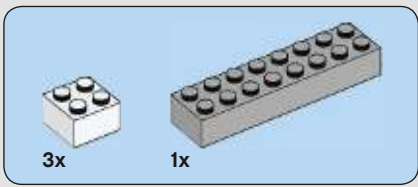

155

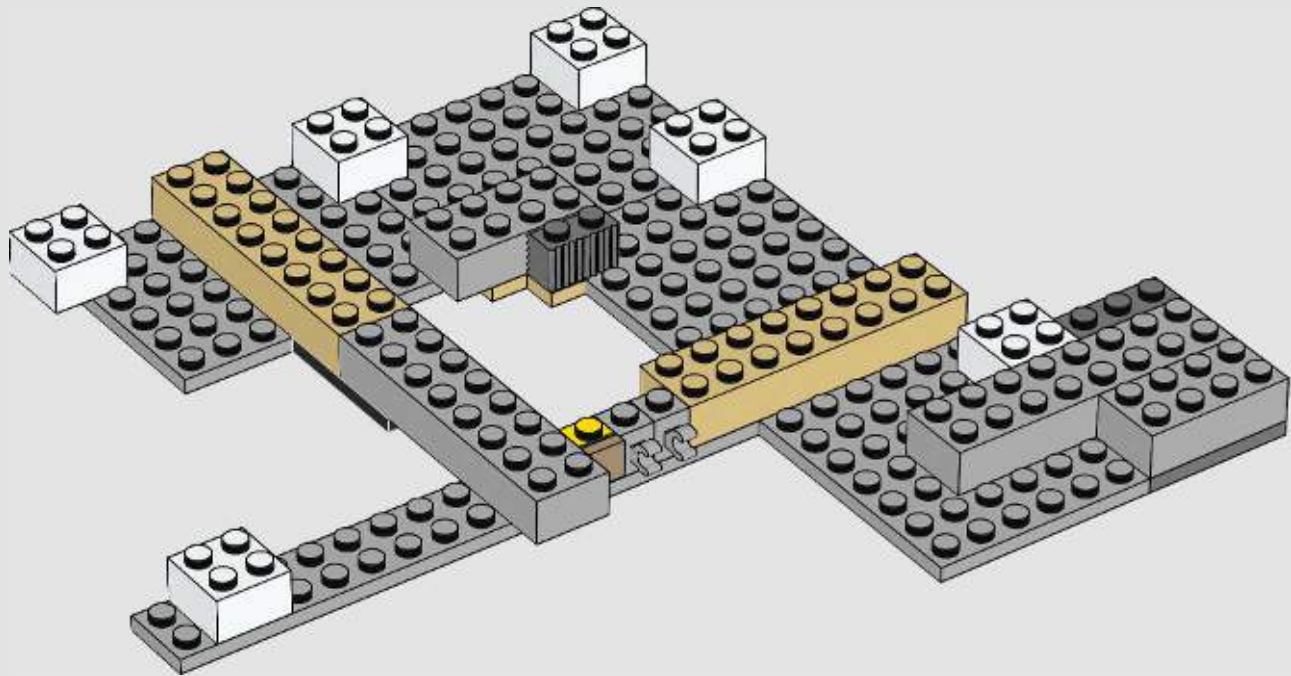

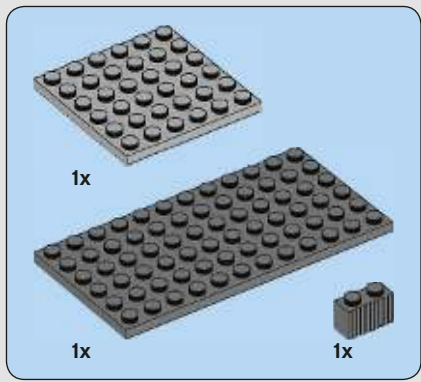

156

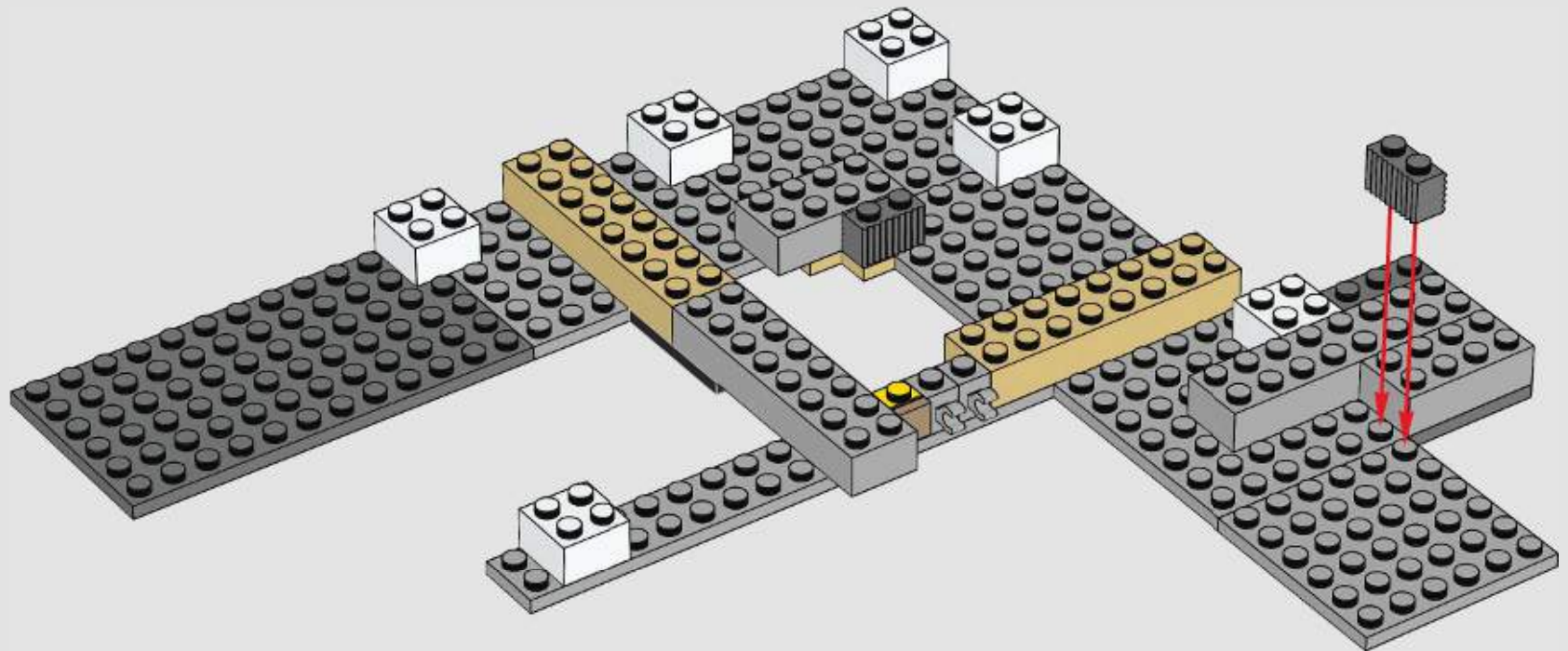

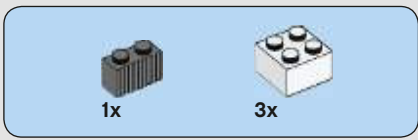

157

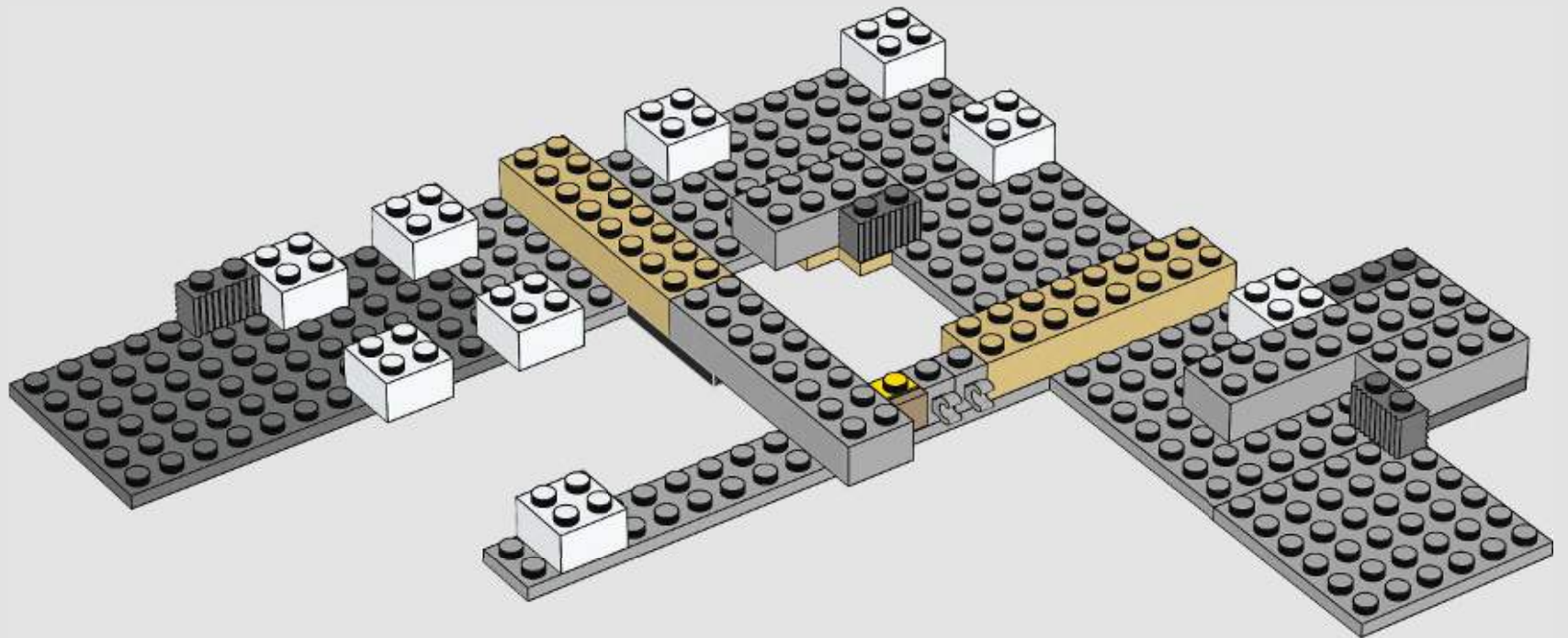

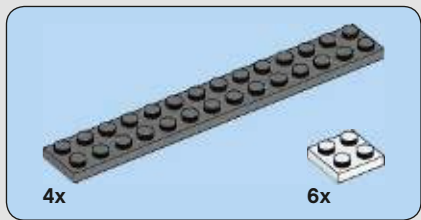

158

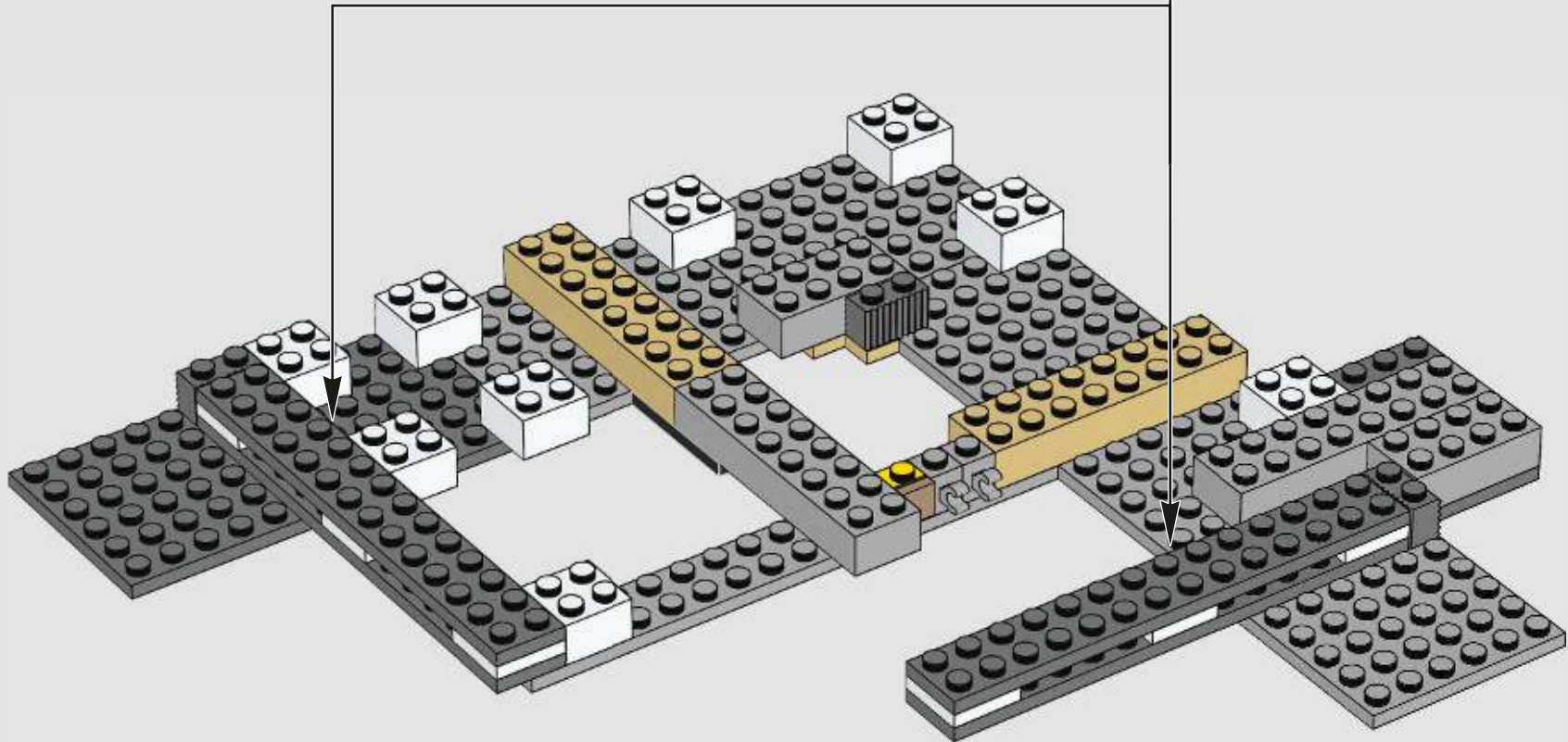
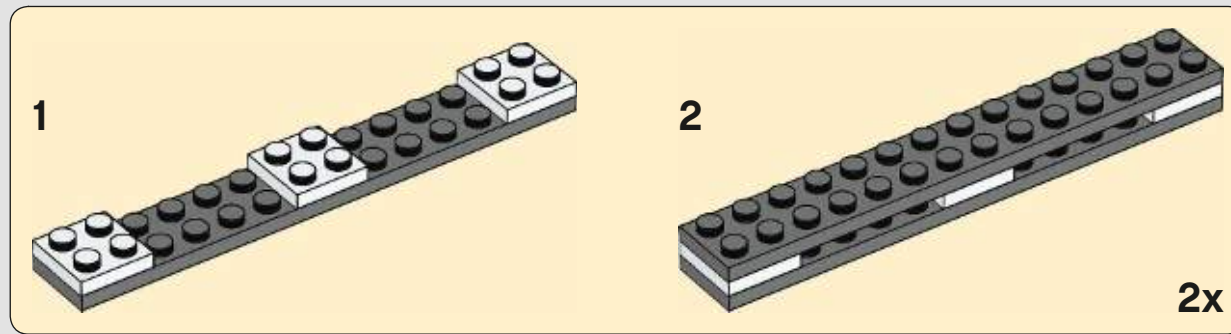

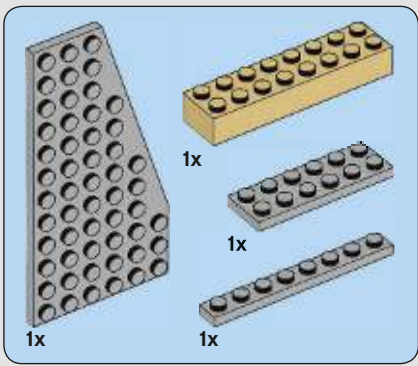

159

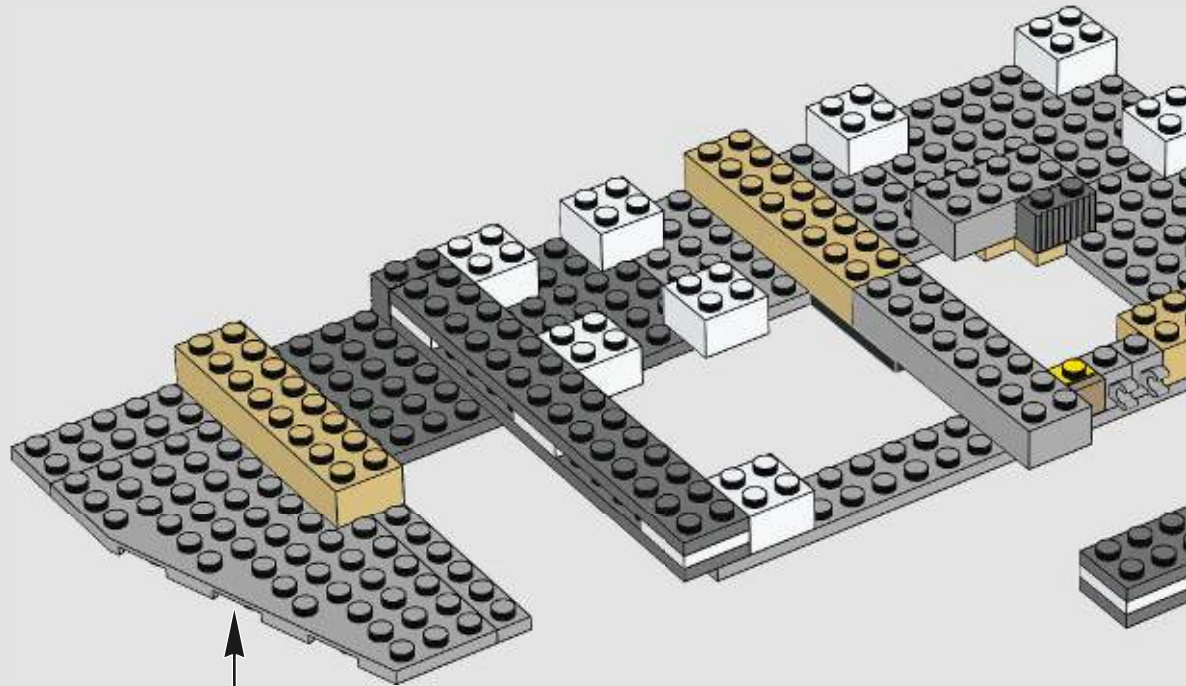
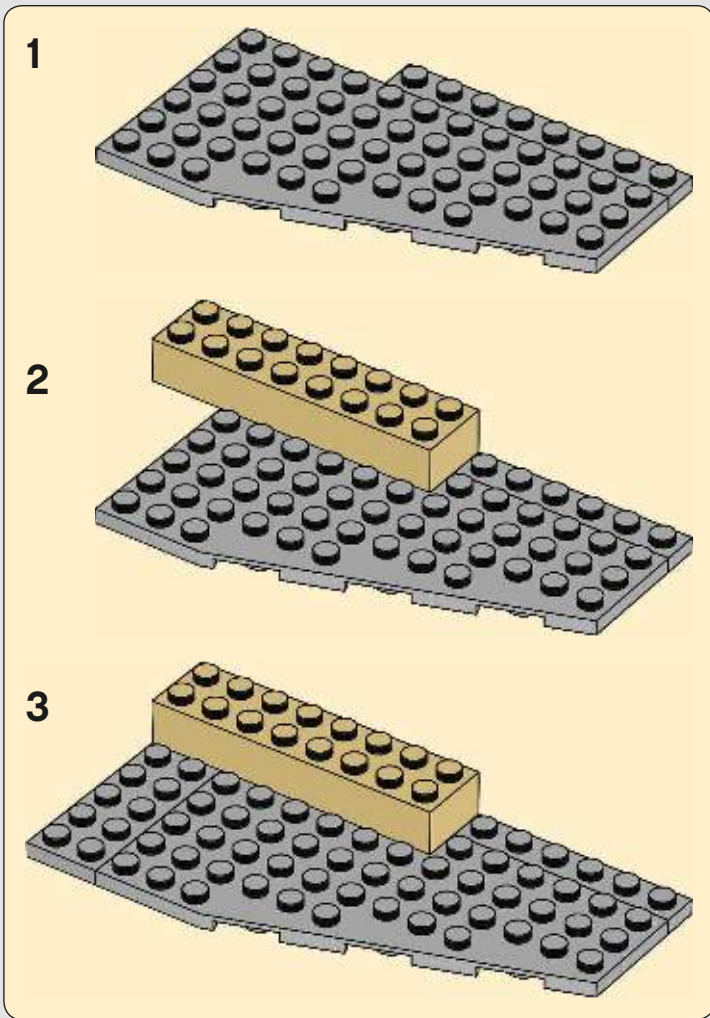

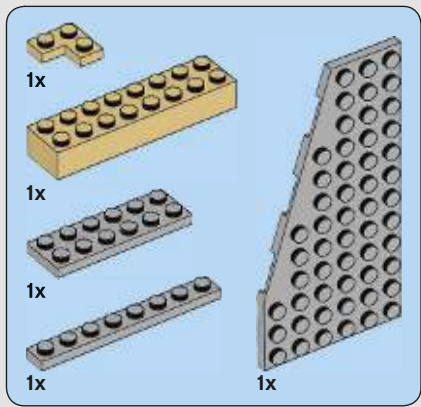

160

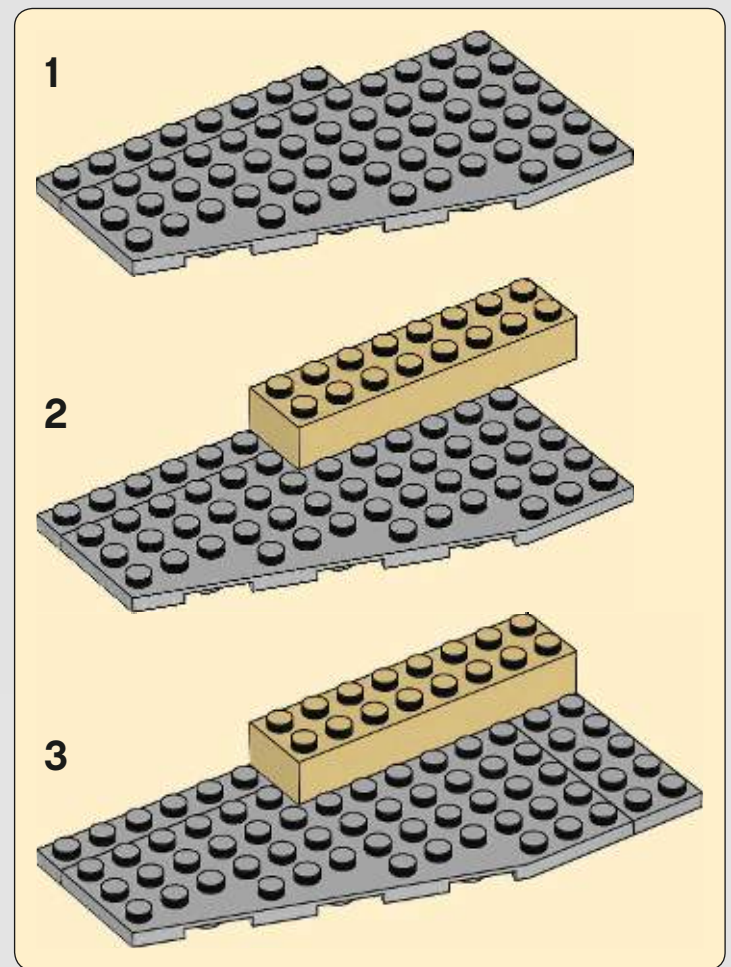
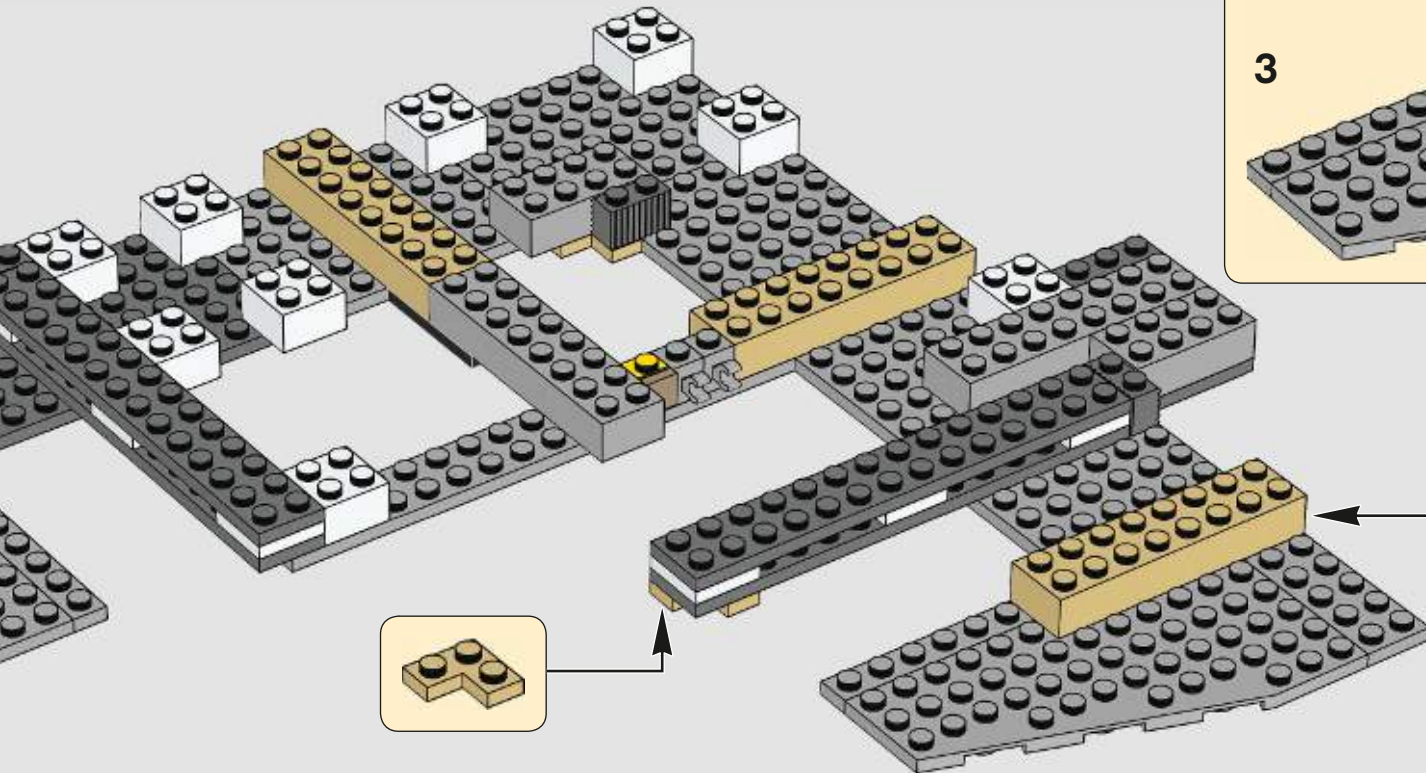

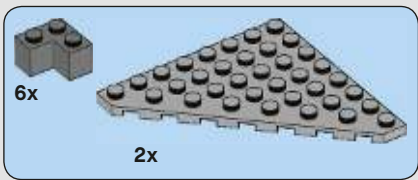

161

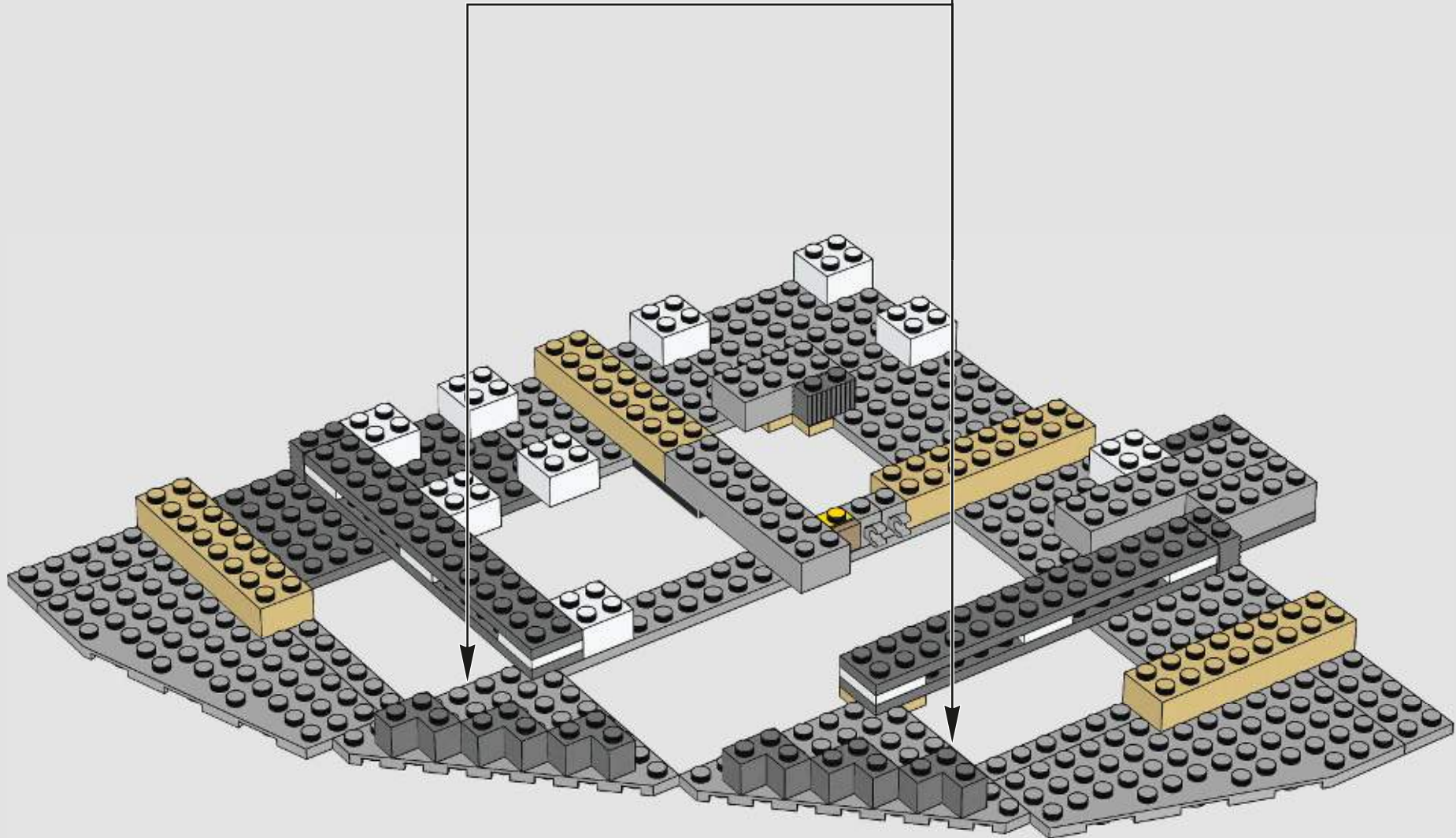
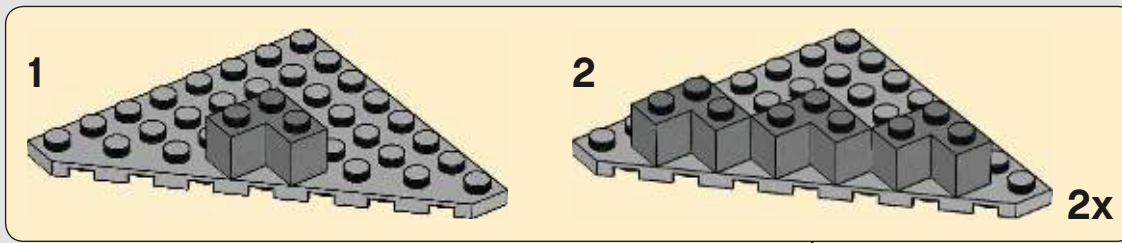

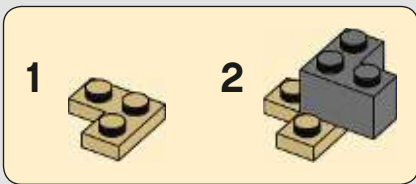

162

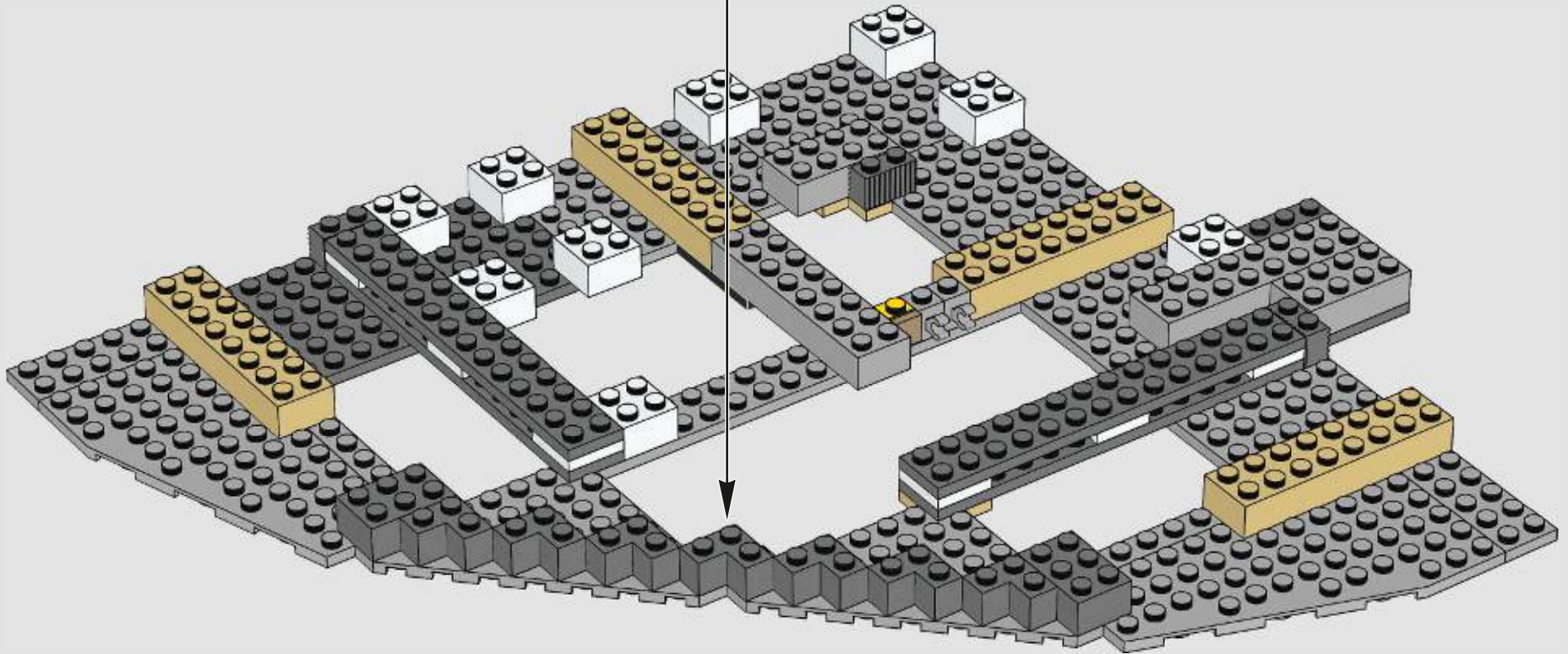



163

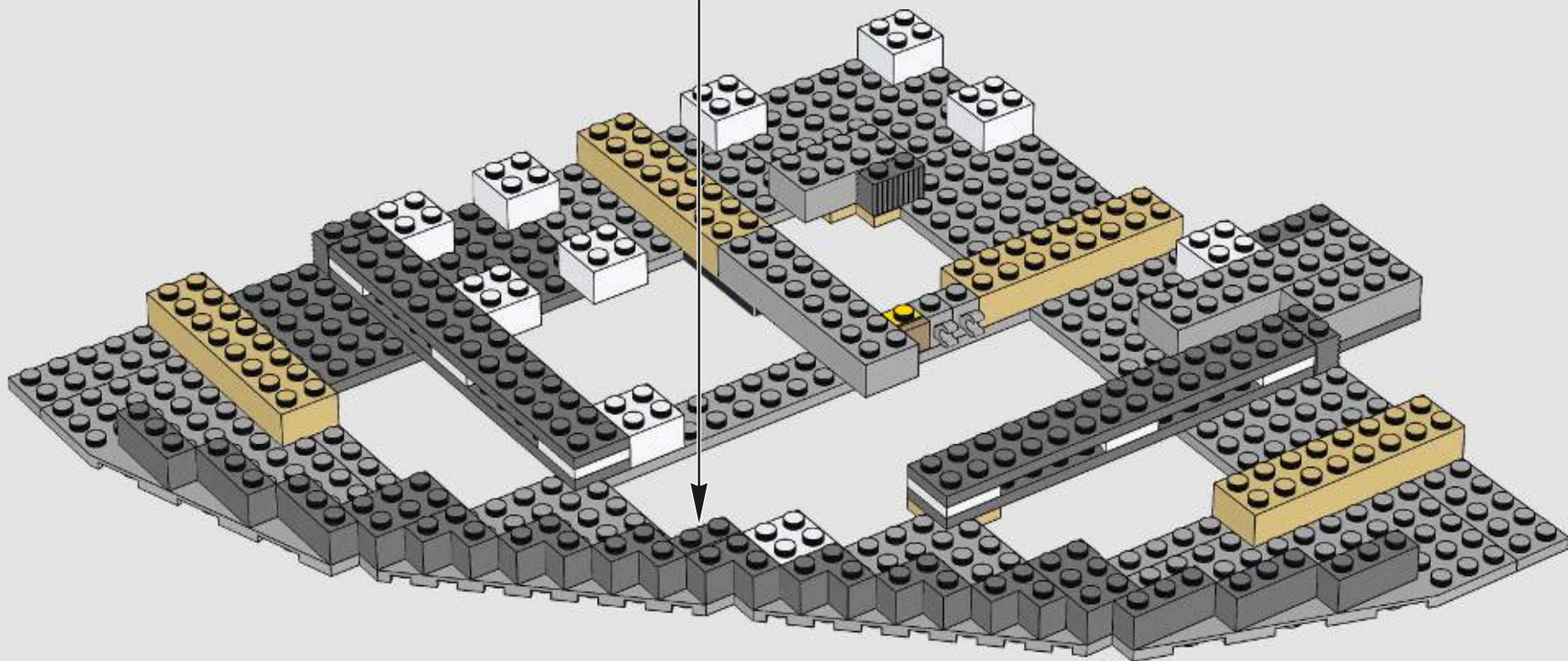
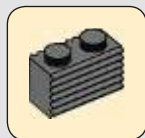

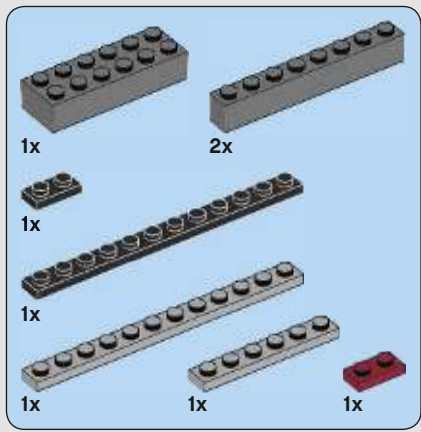

164

1

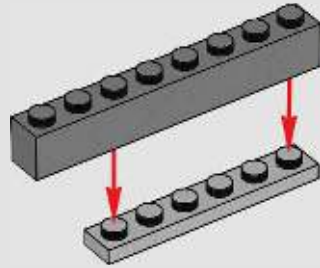

2

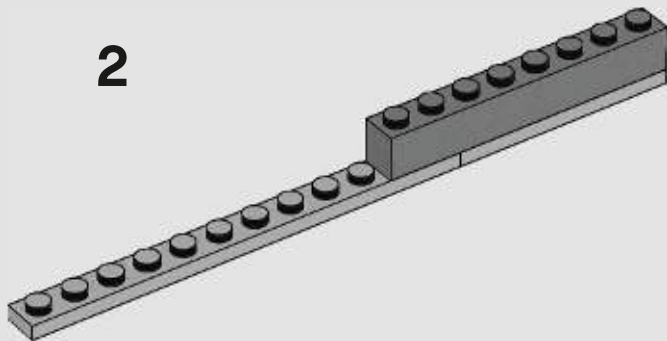

3

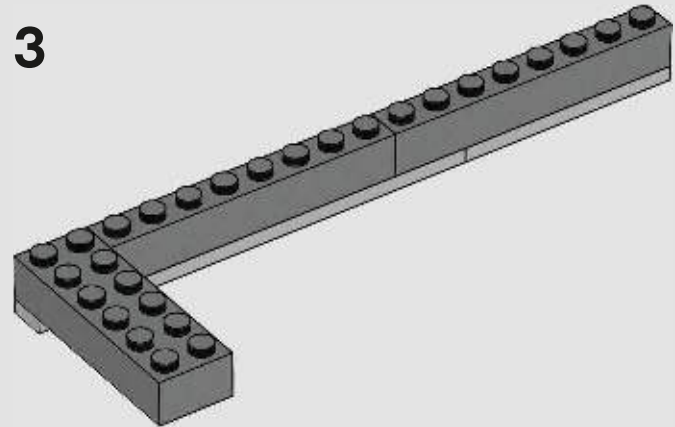

4

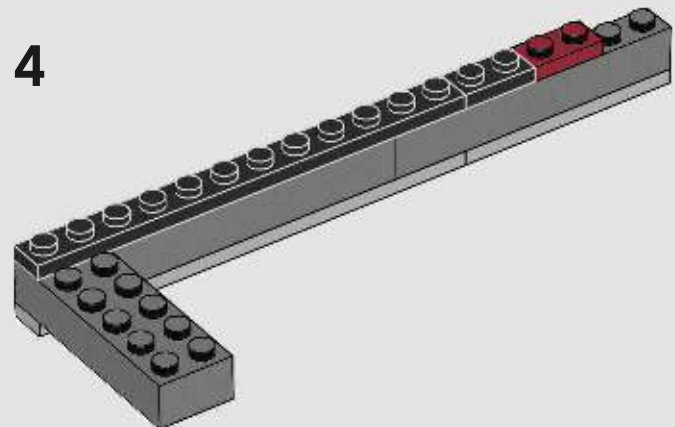

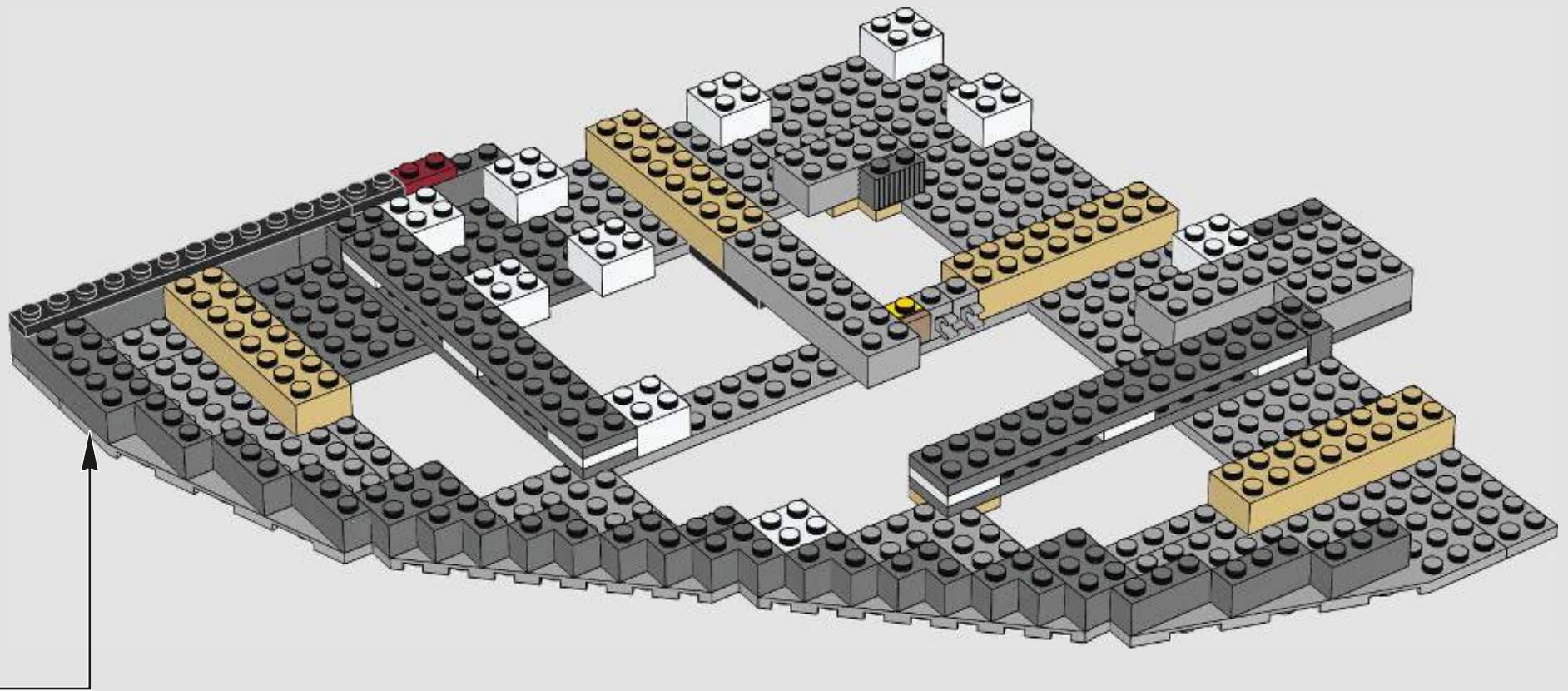

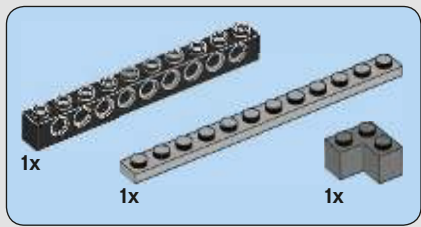

165

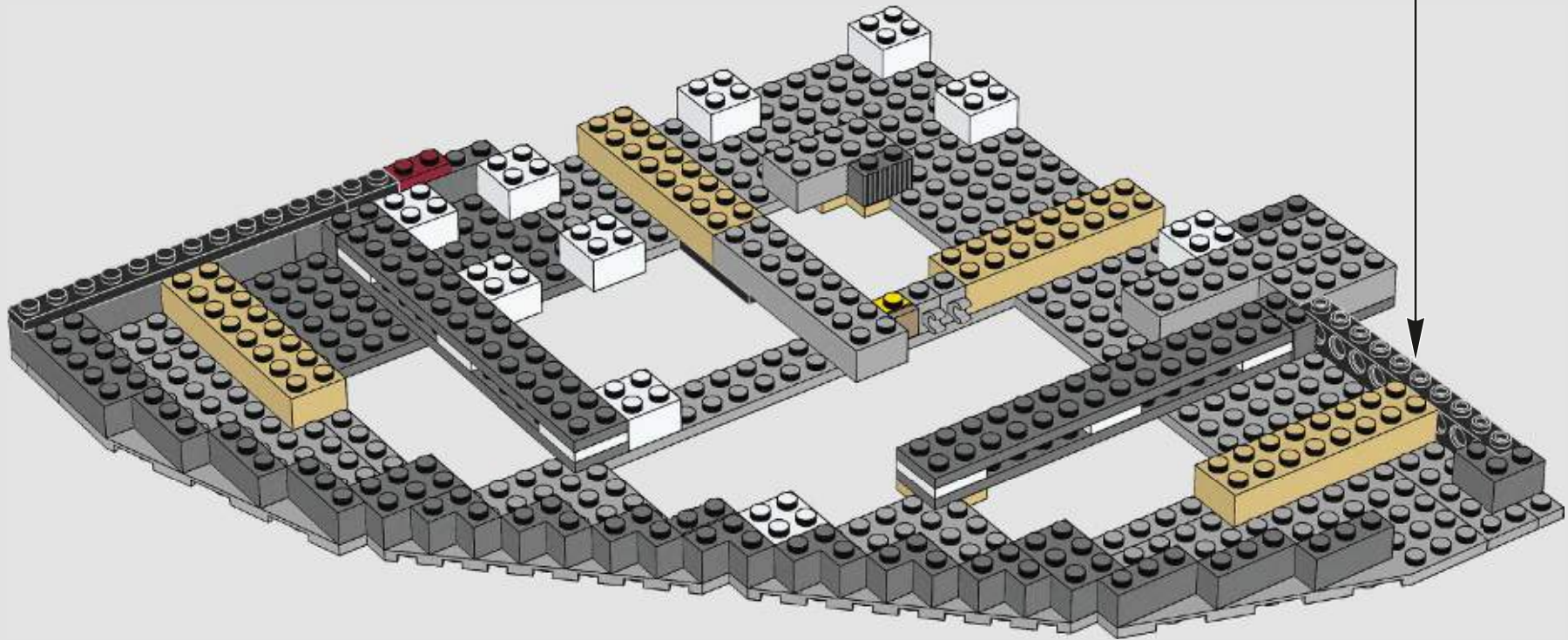
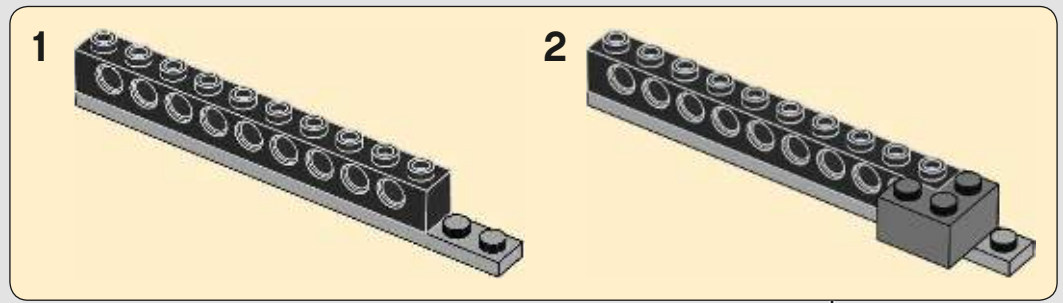

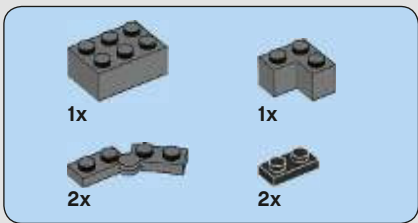

166

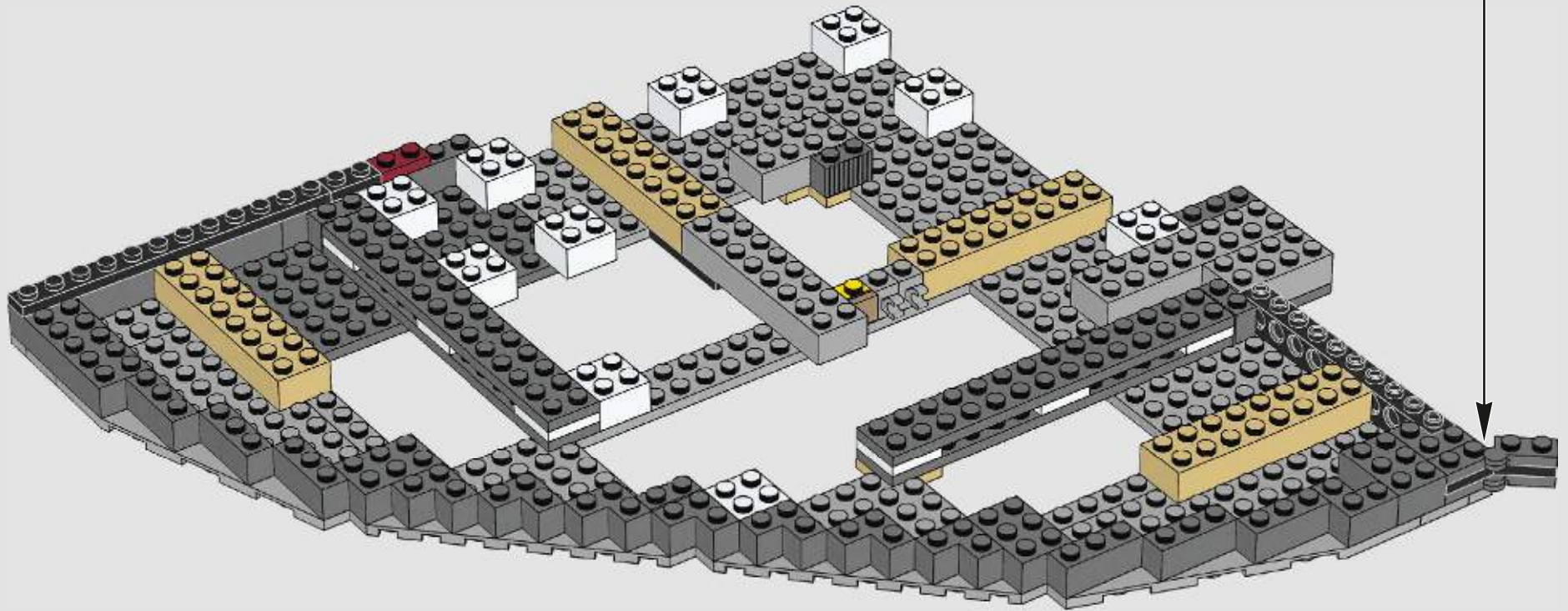

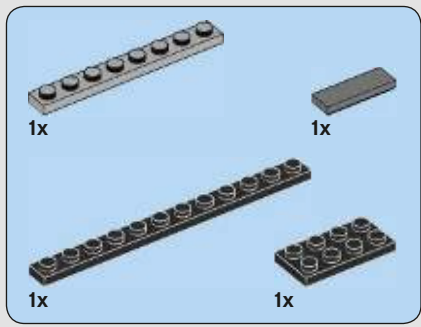

167

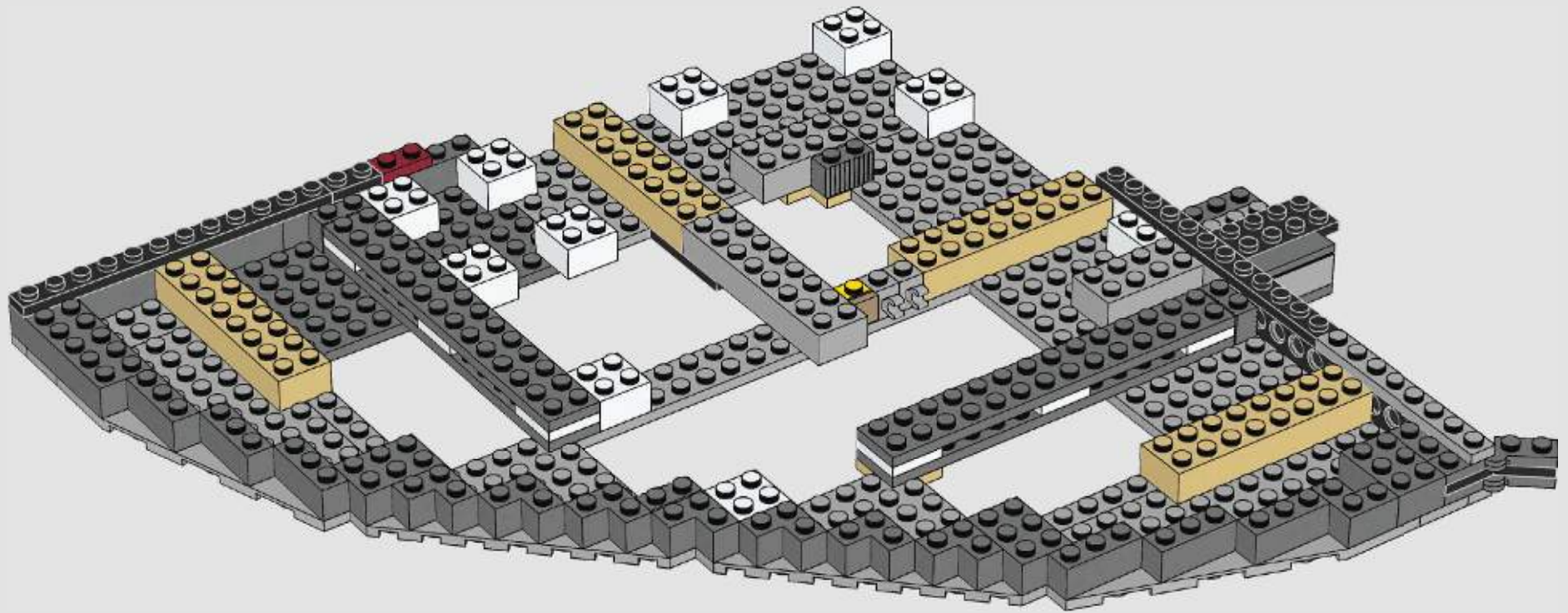

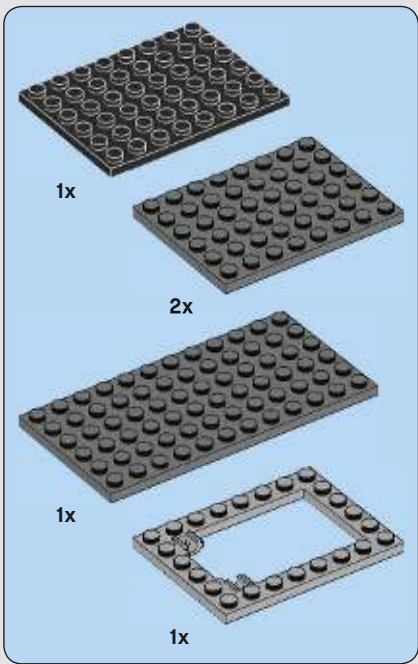

168

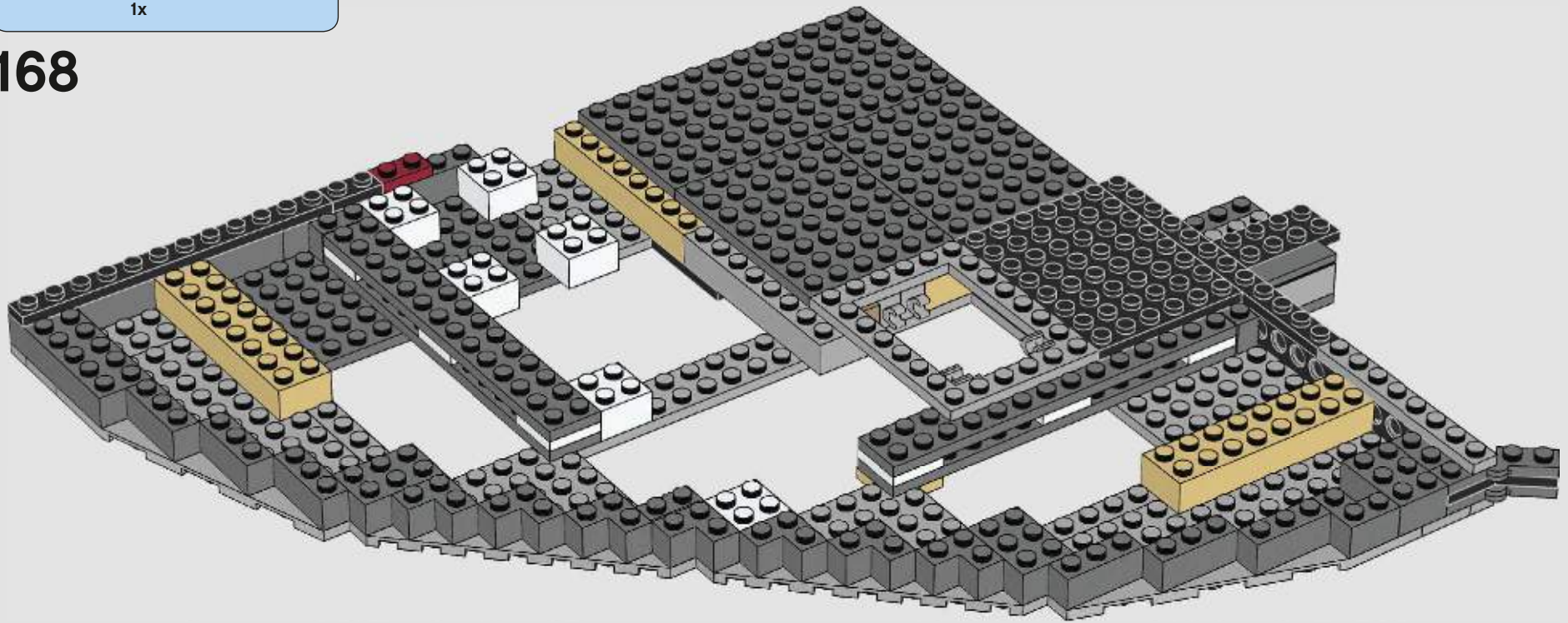

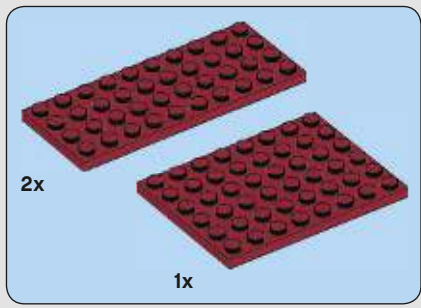

169

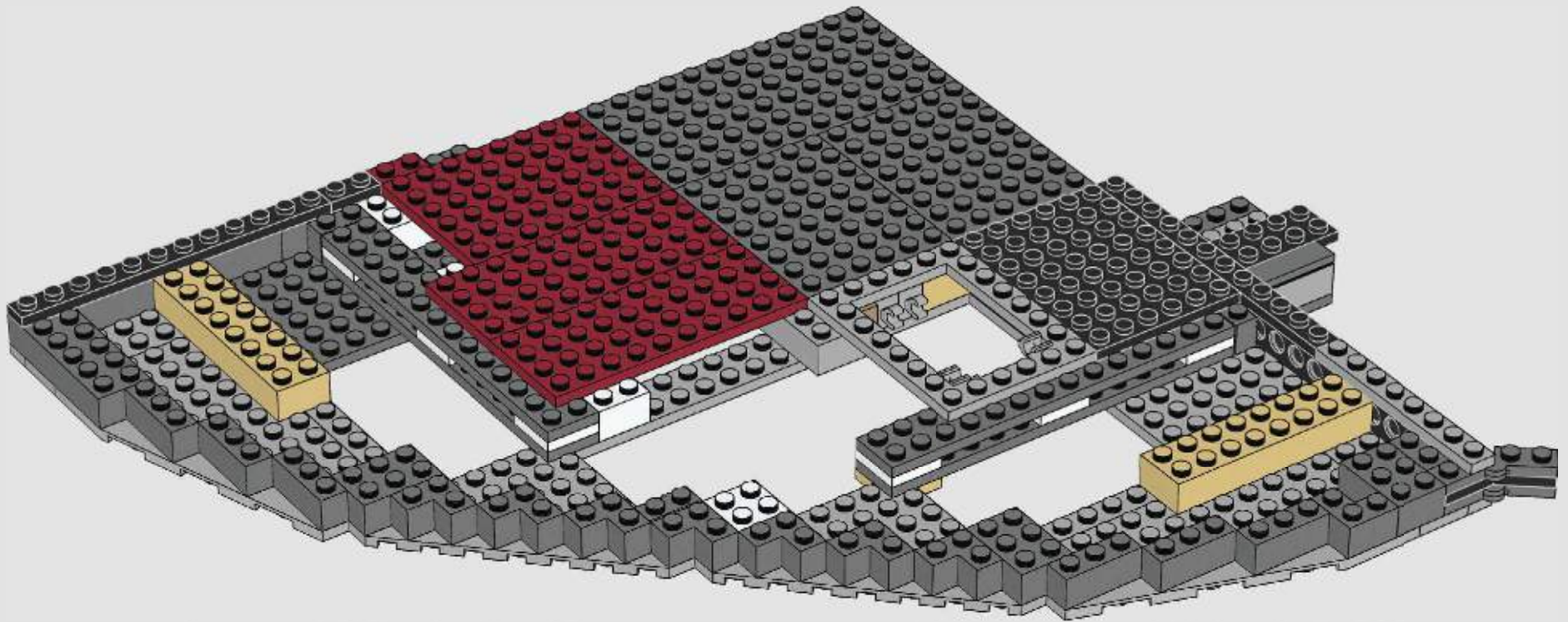

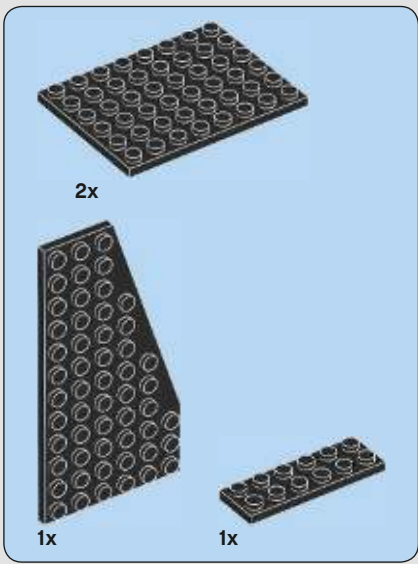

170

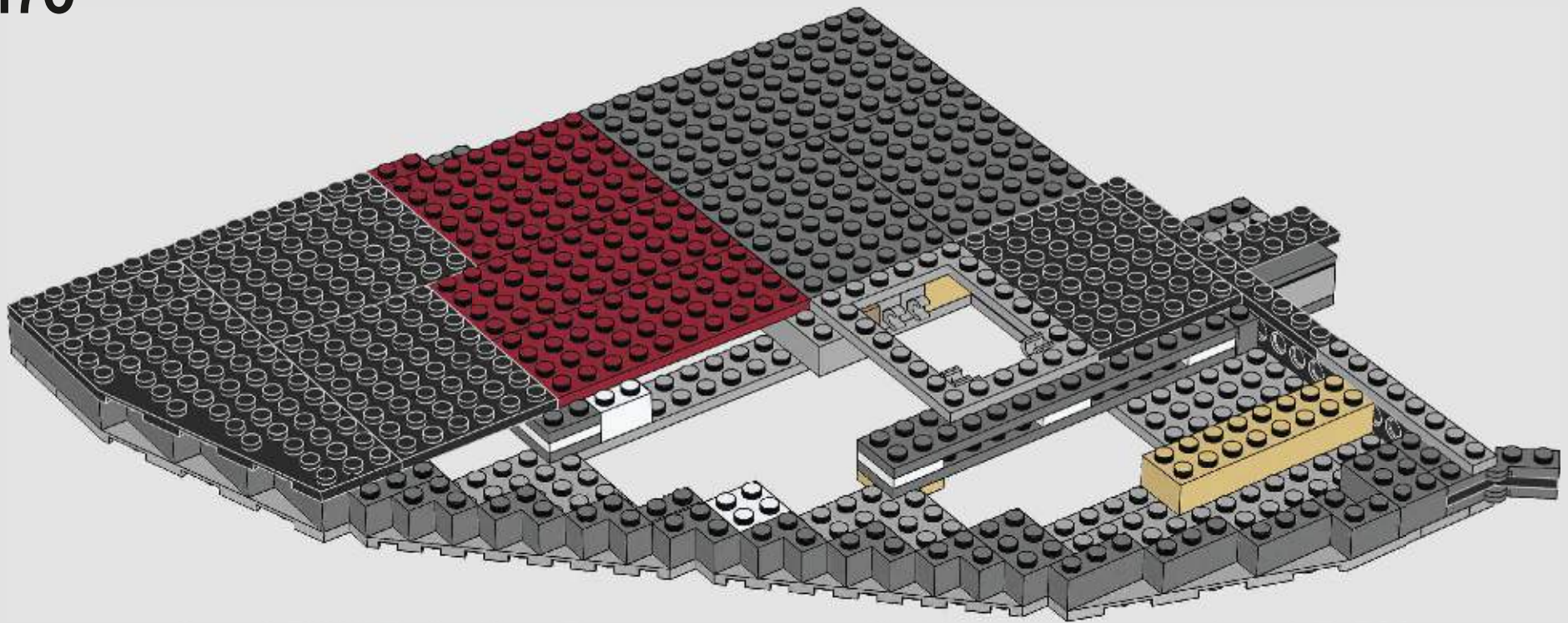

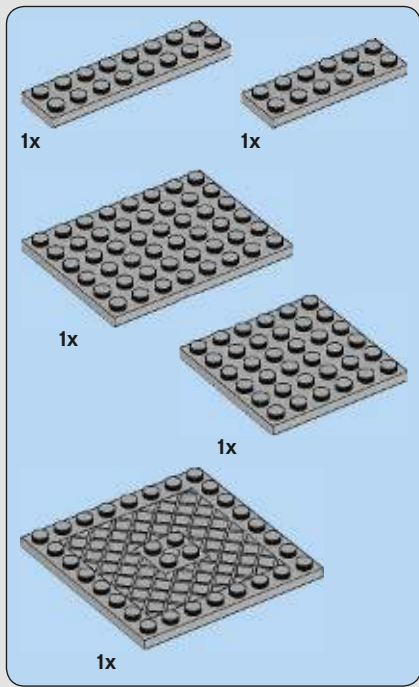

171

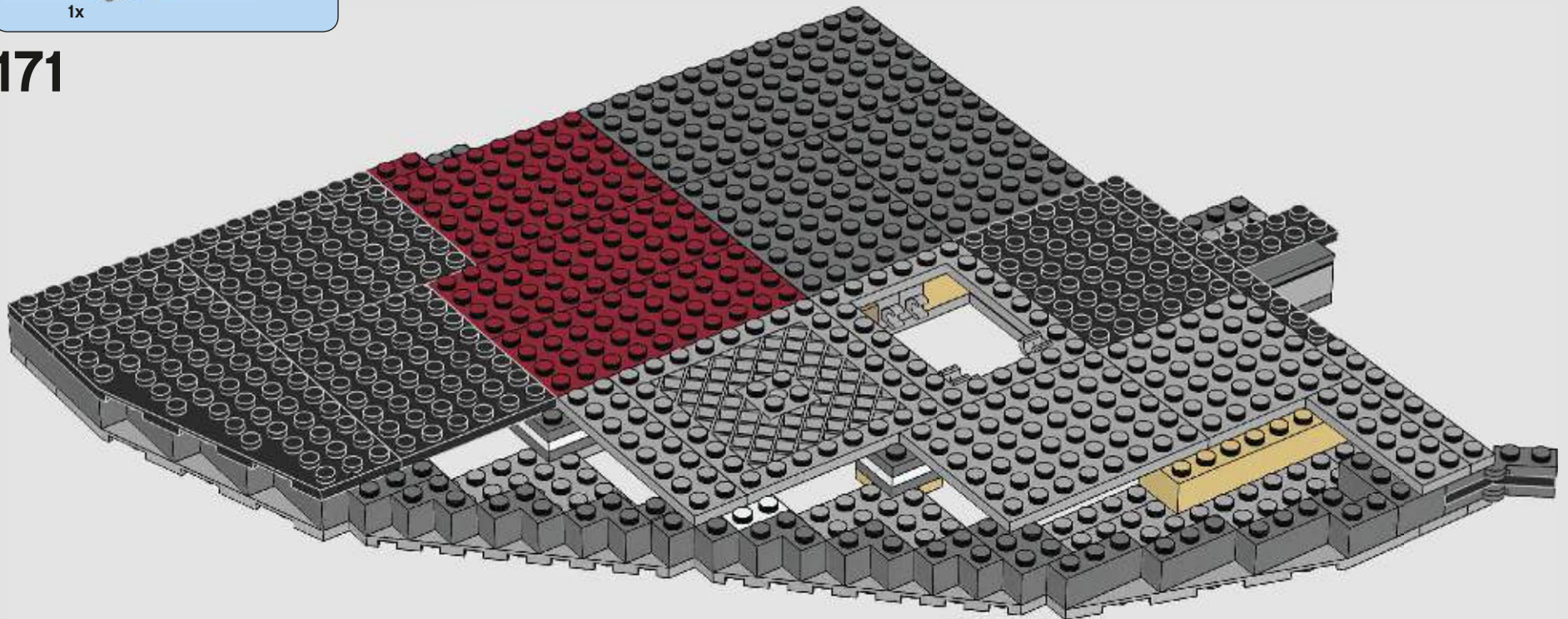

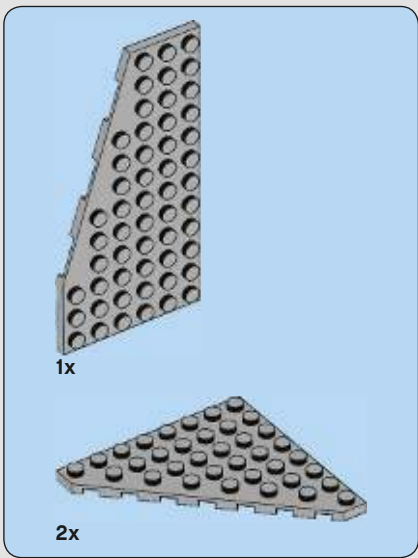

172

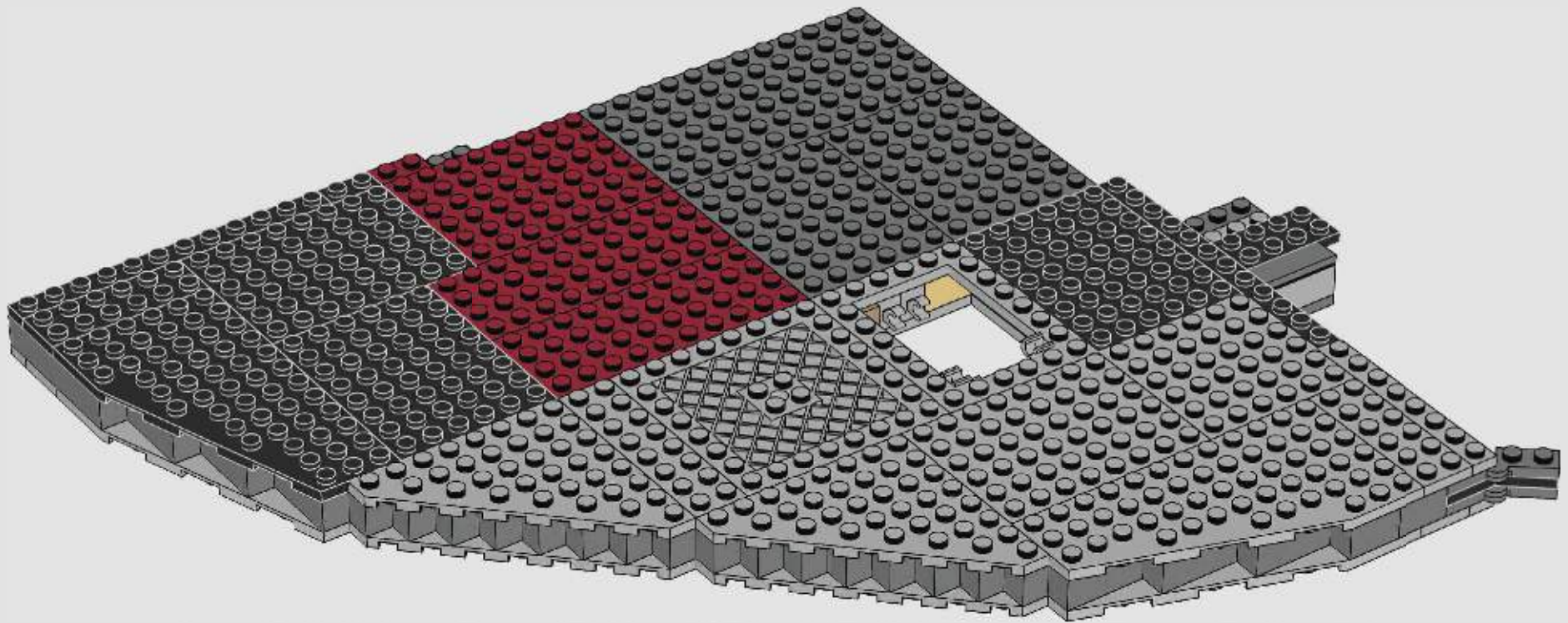

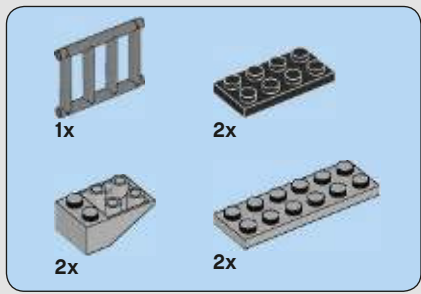

173

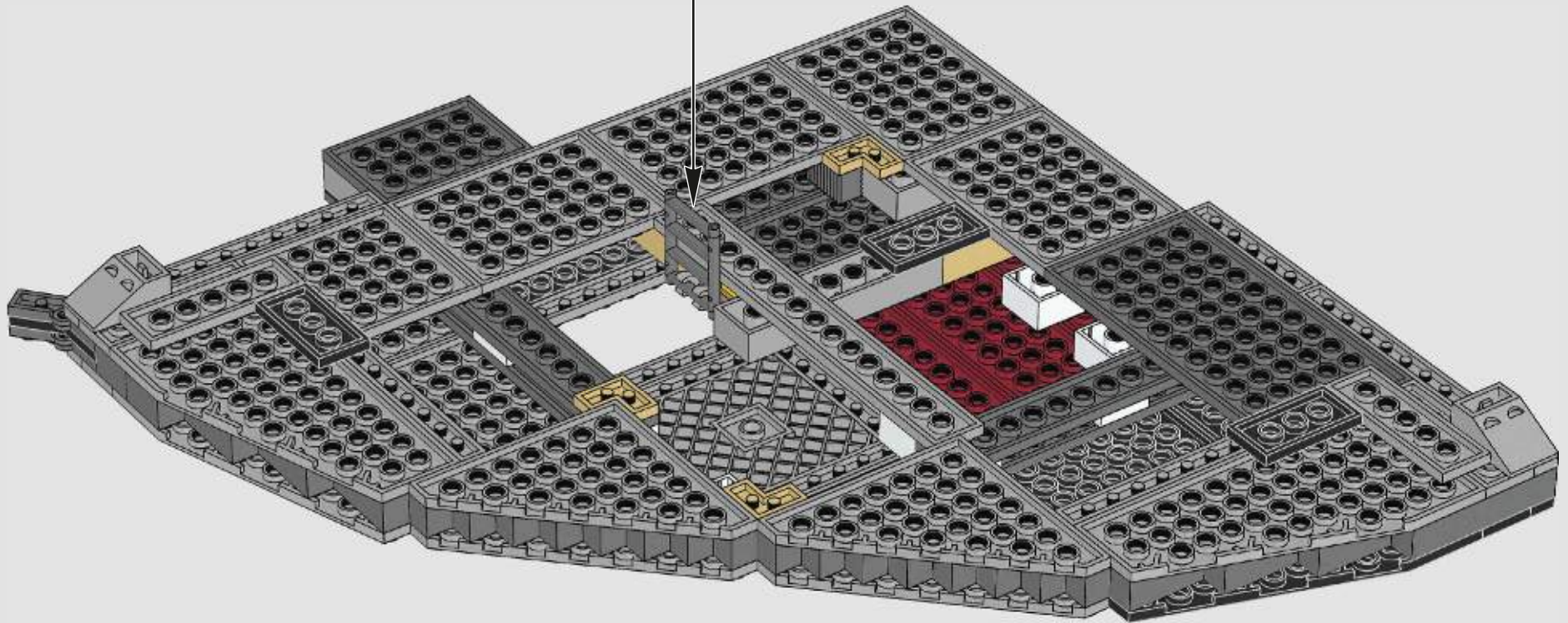
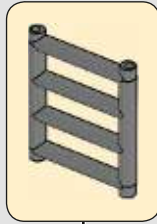
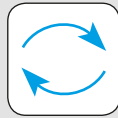

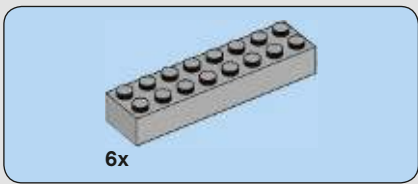

174

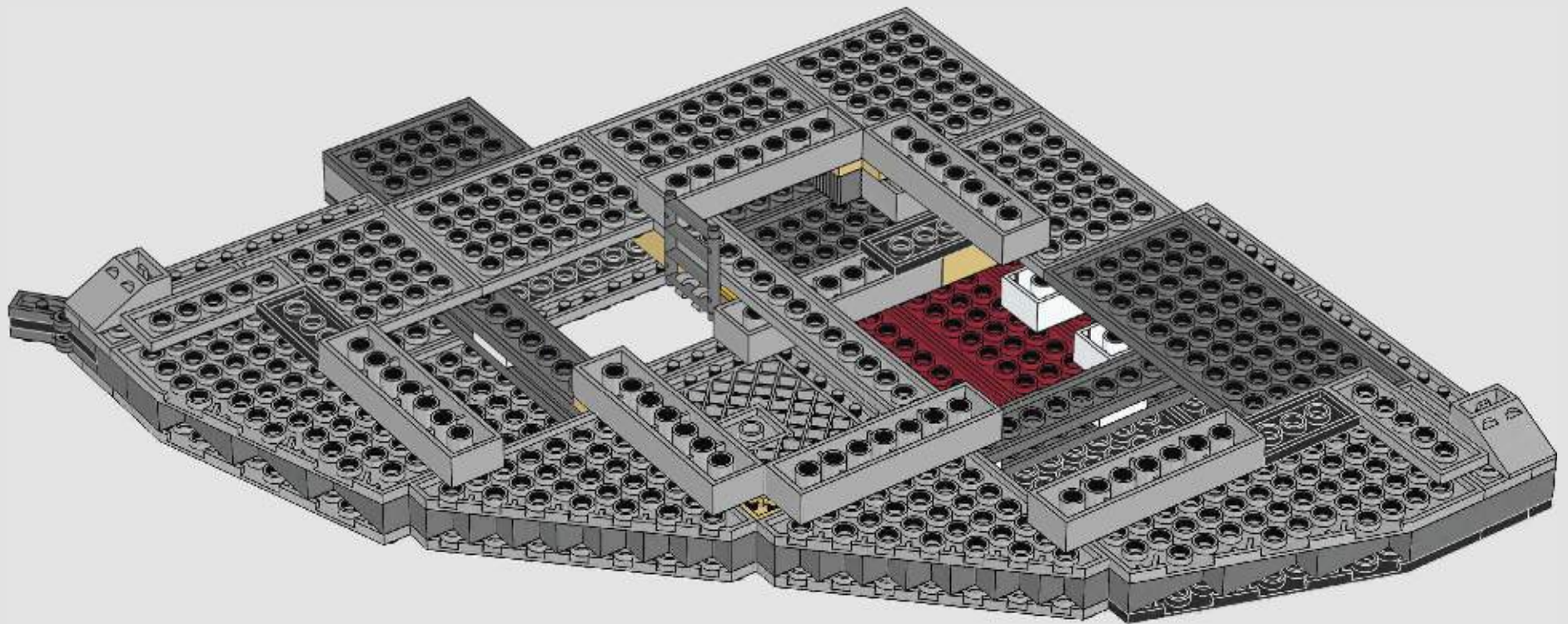

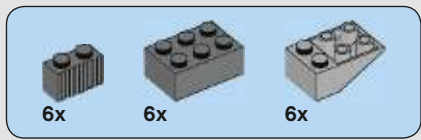

175

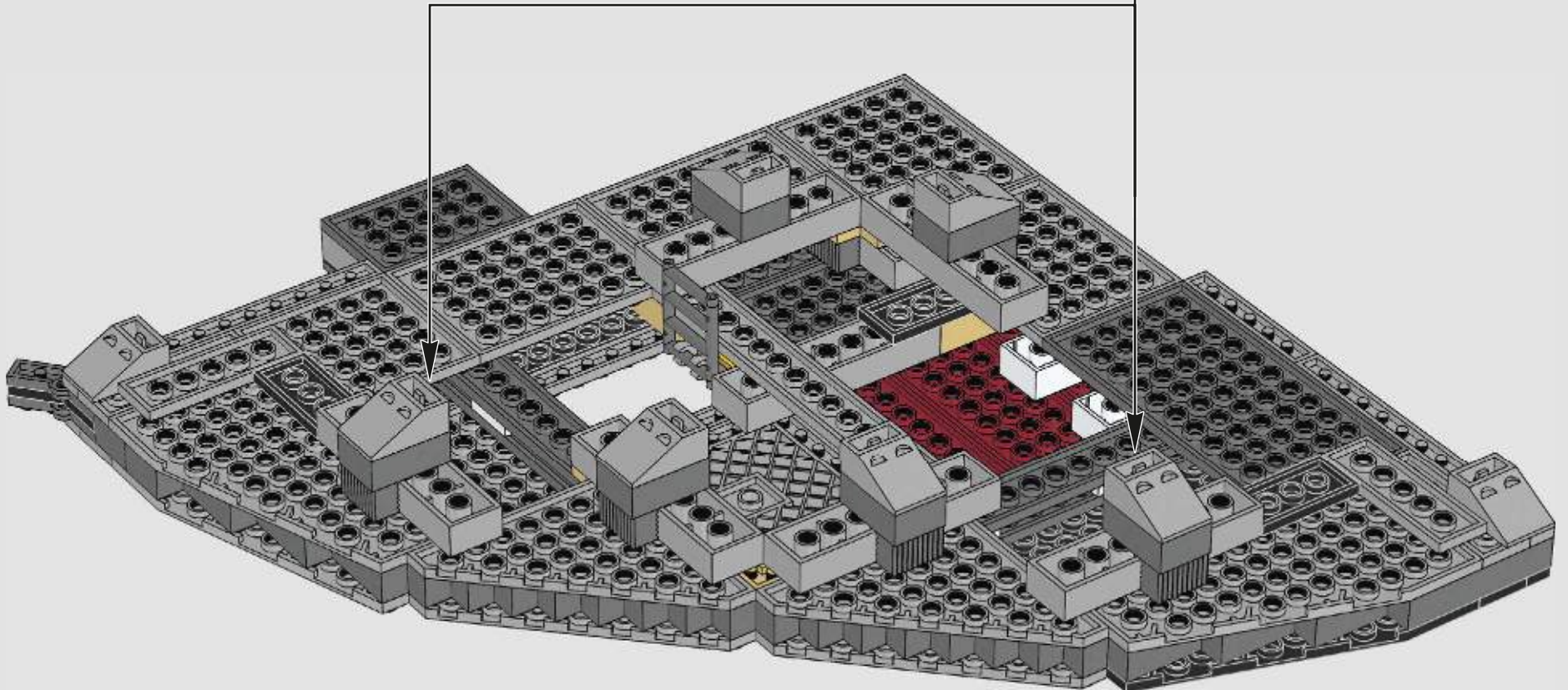
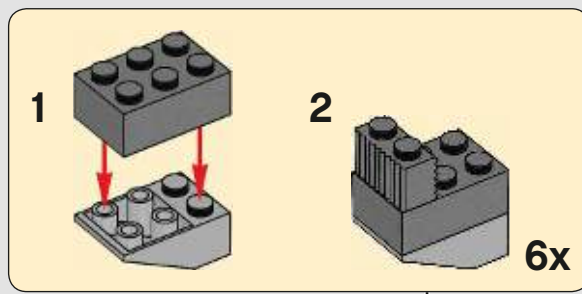

176

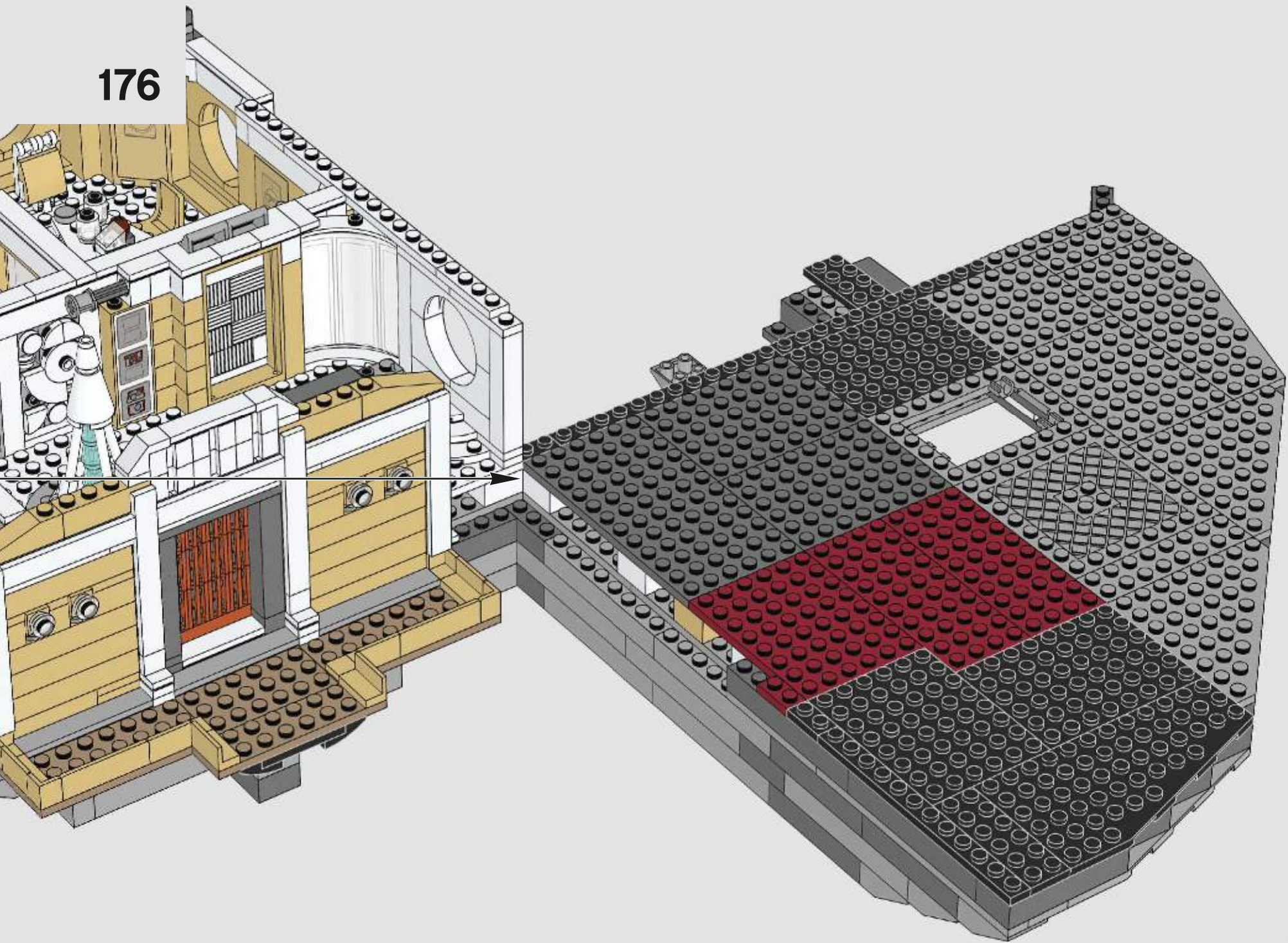

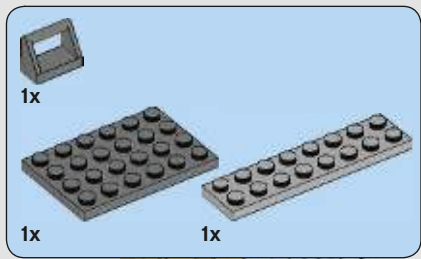

177

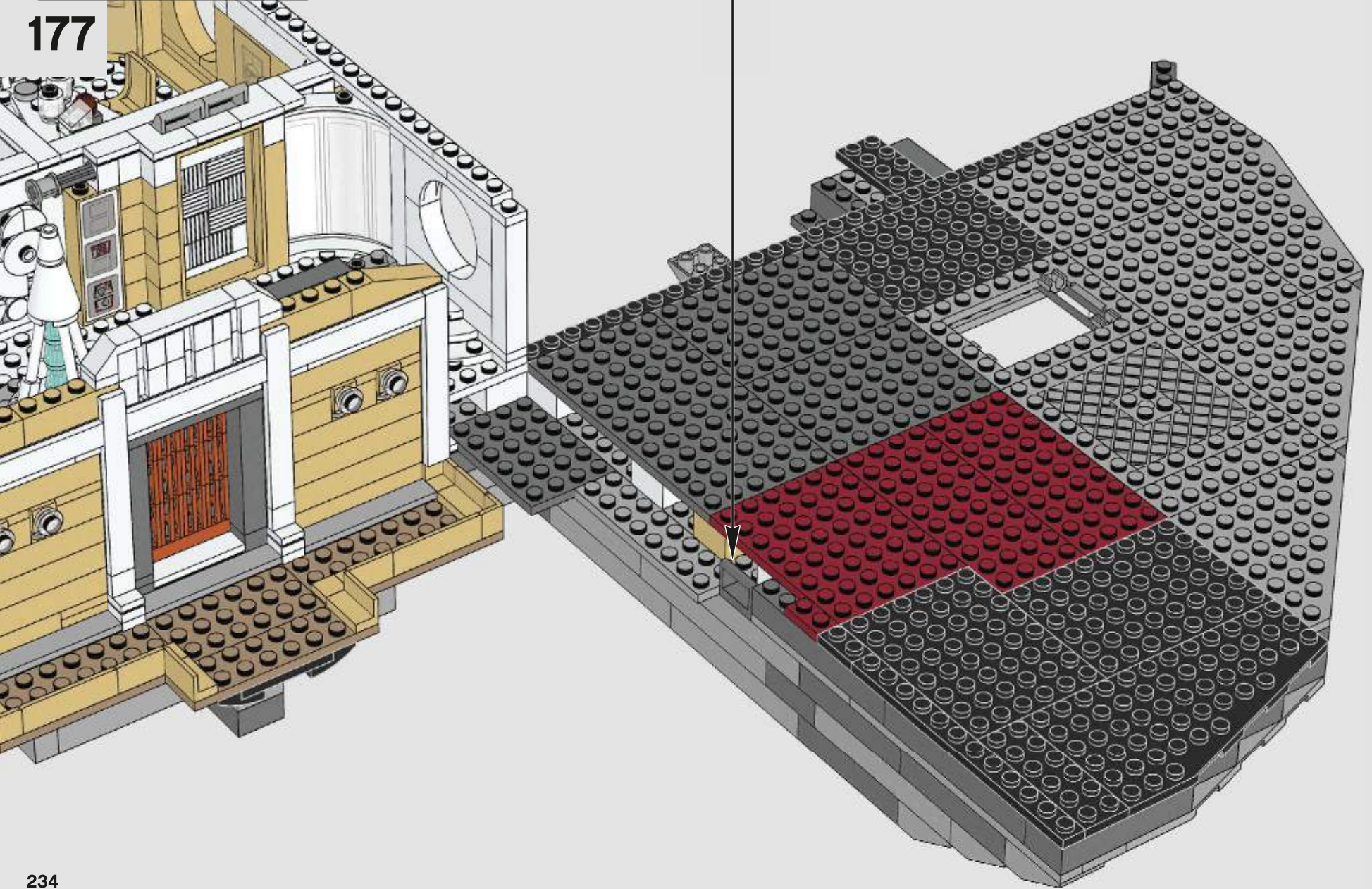
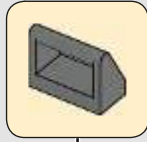



178

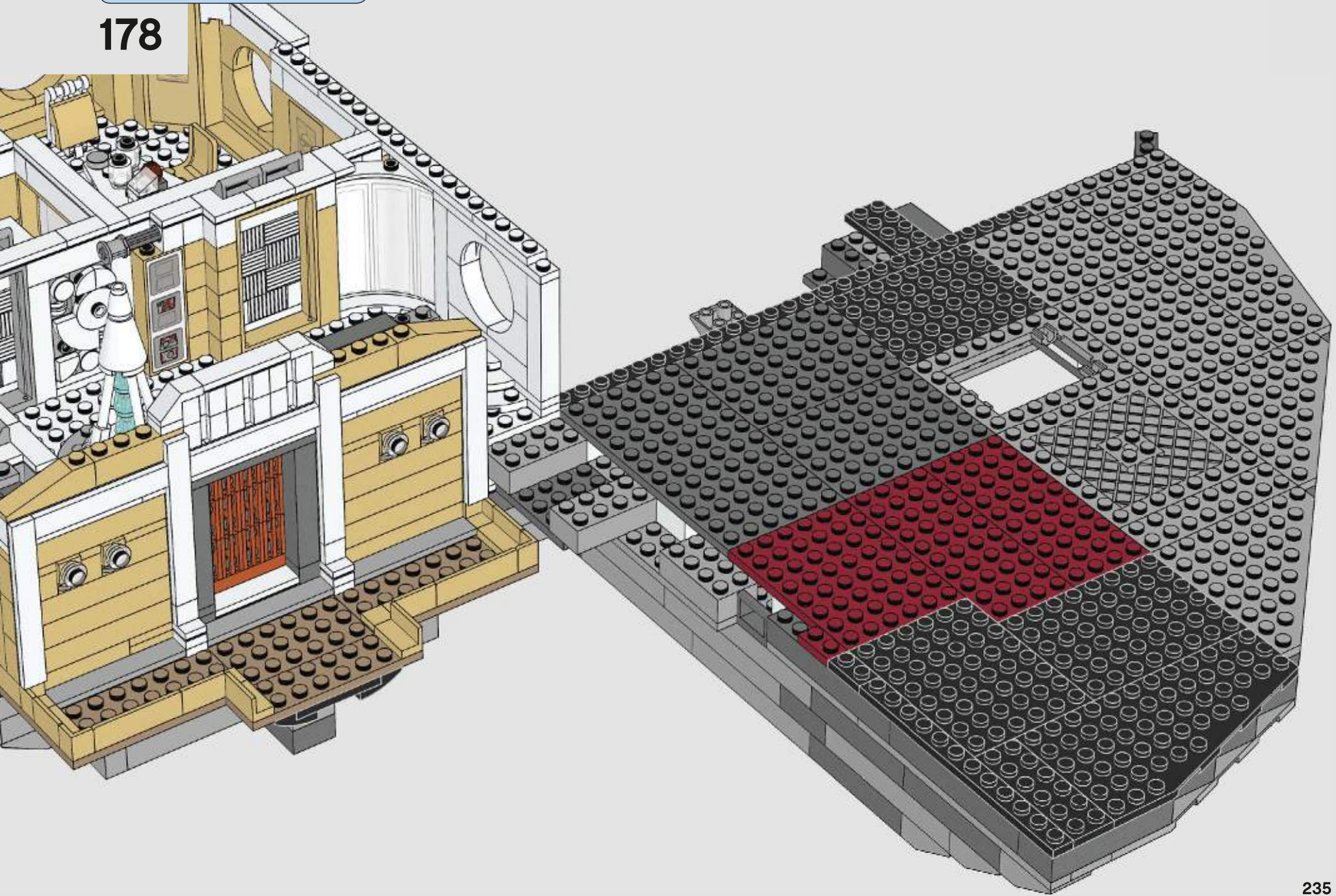

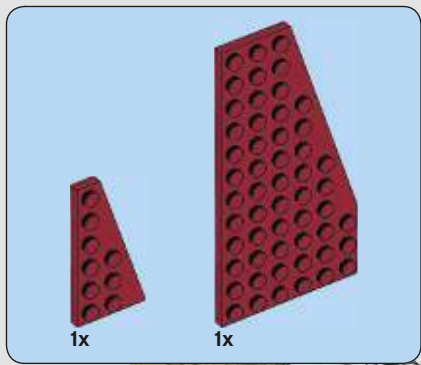

179

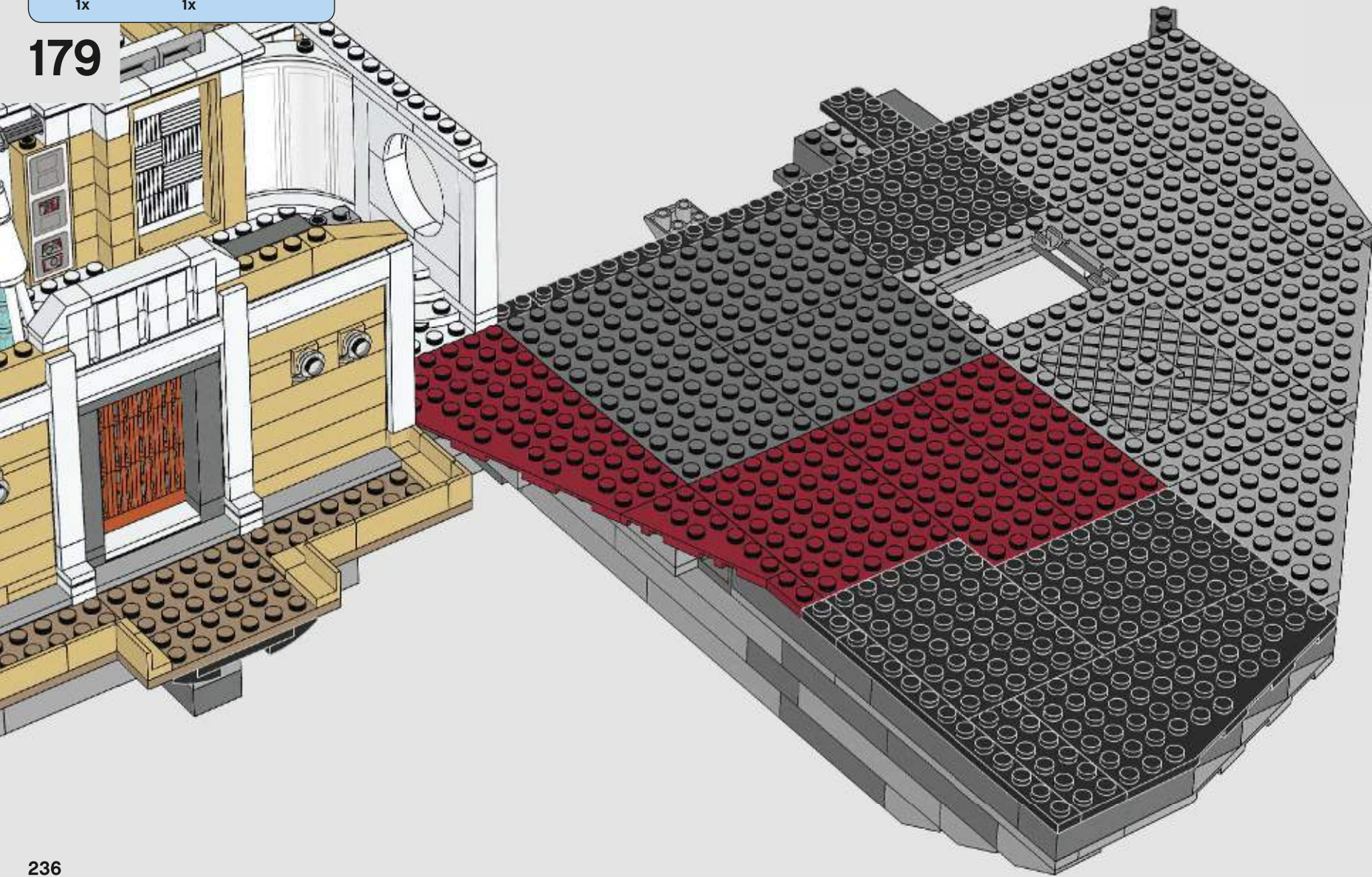

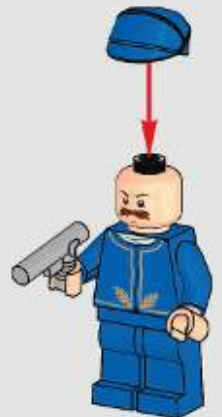
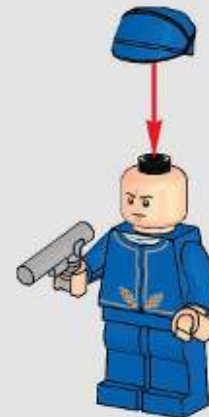
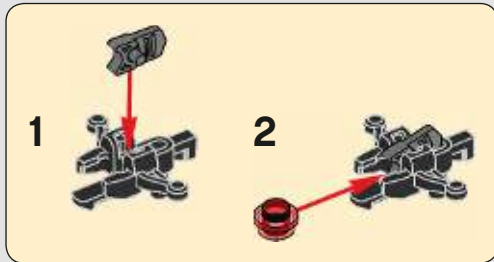
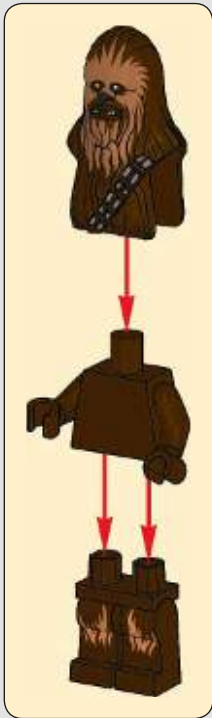
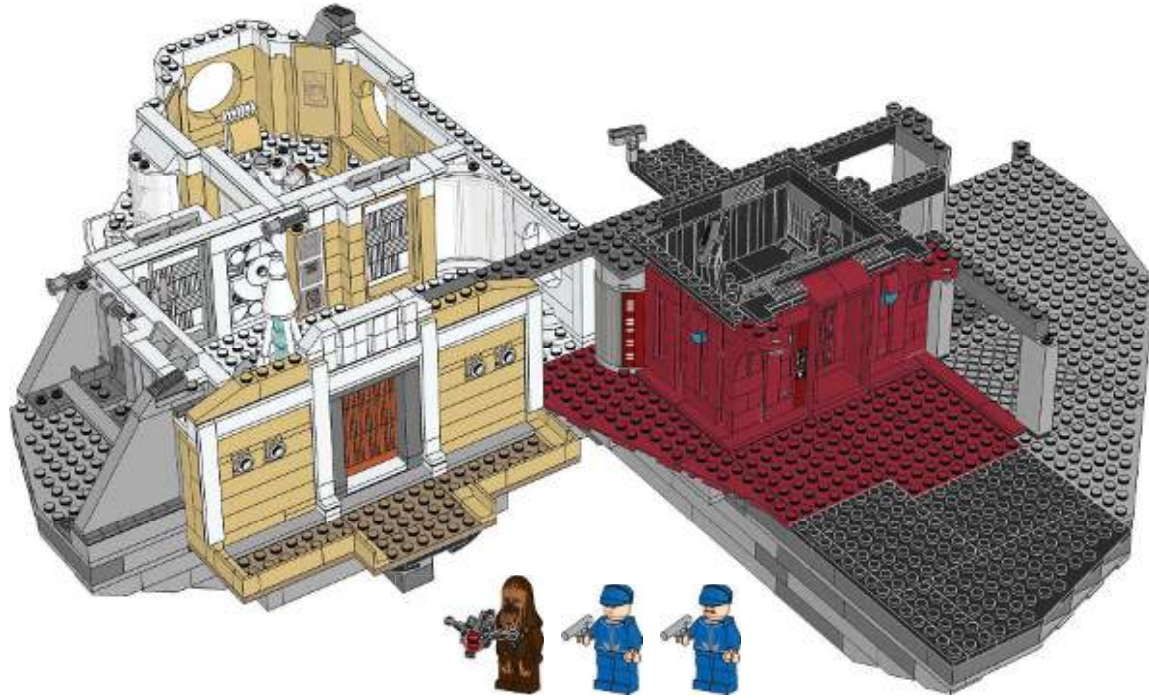

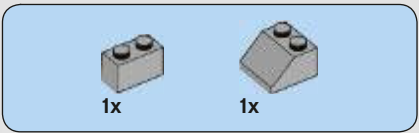

180

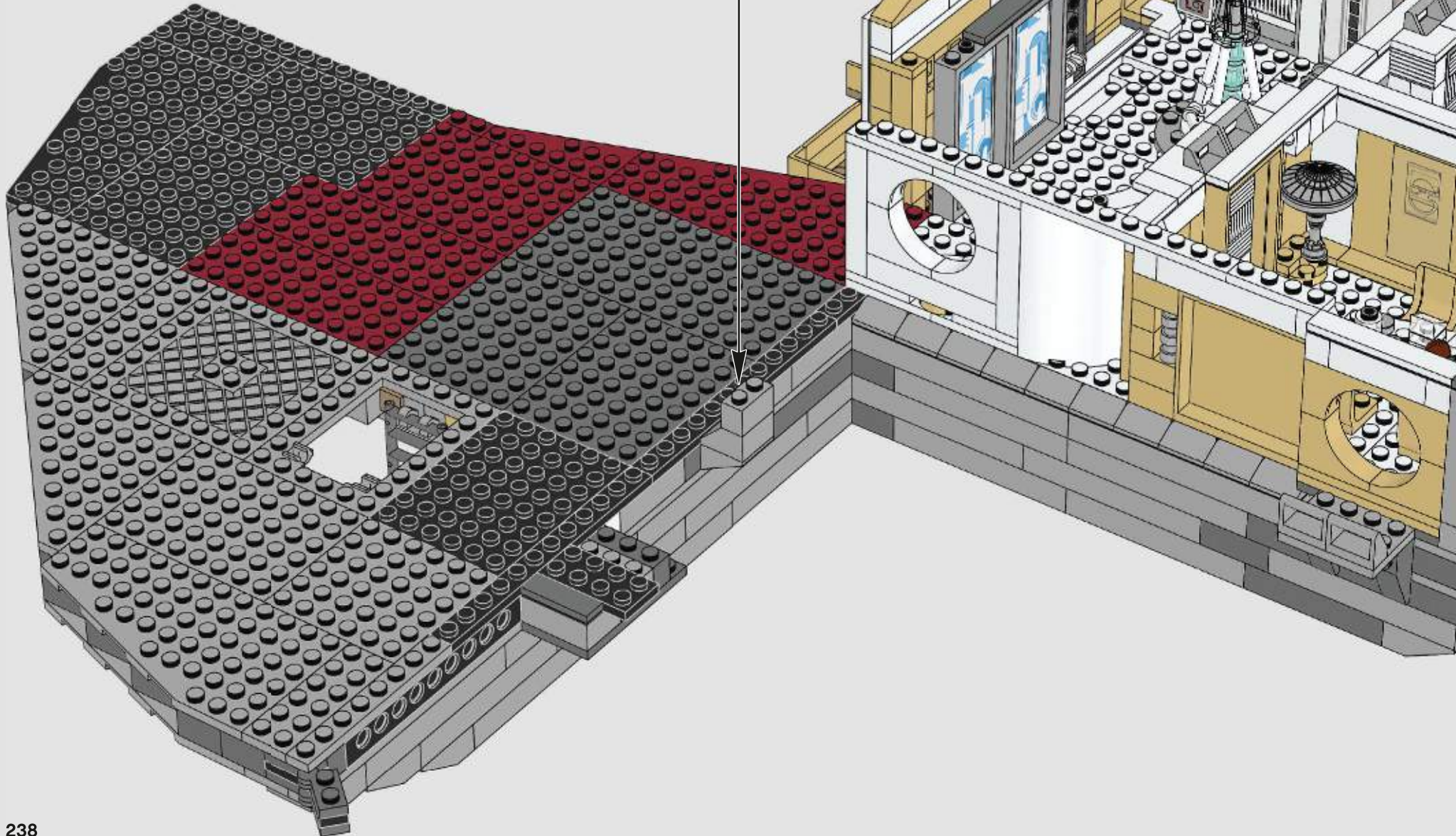
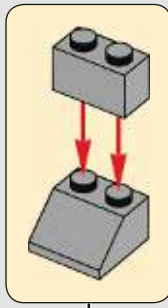
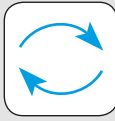

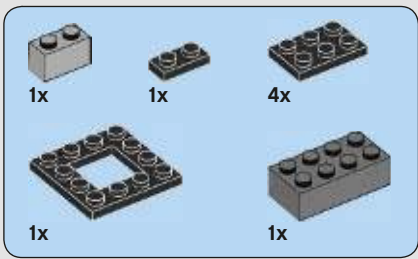

181

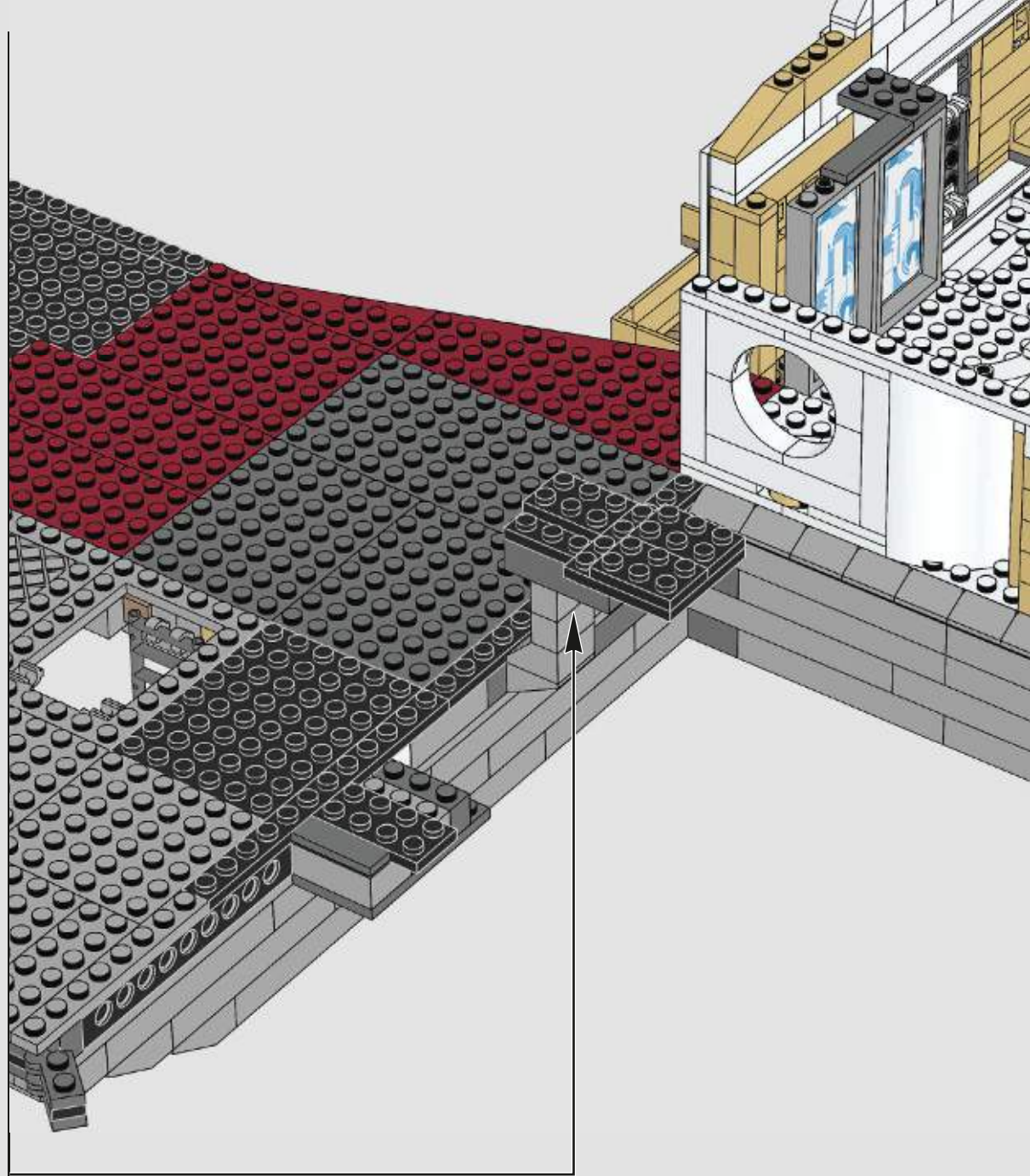
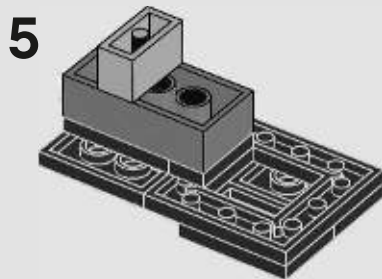
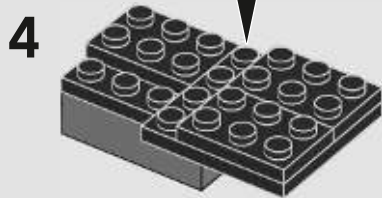
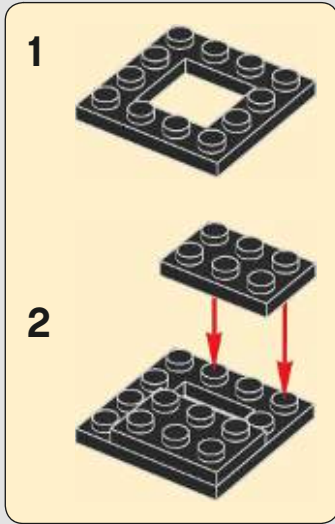
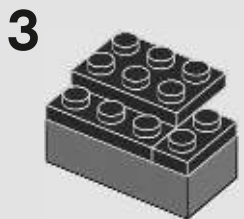
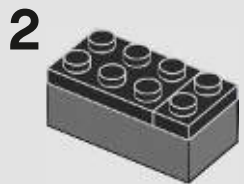
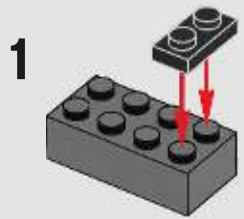

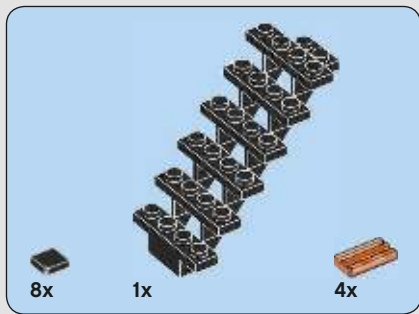

182

1

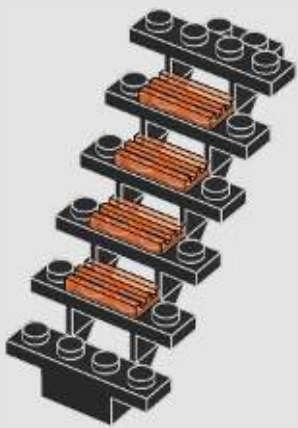

2

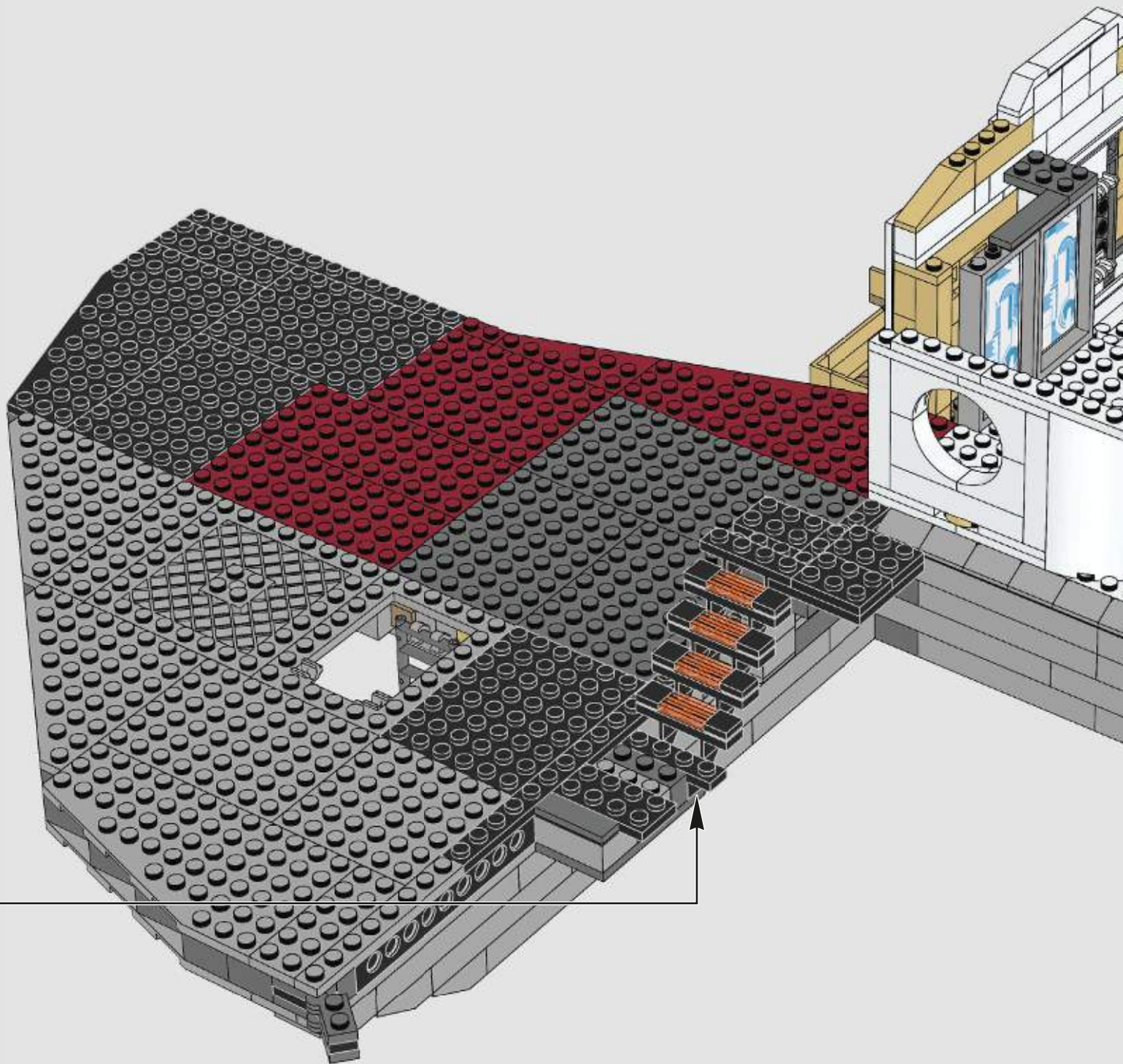
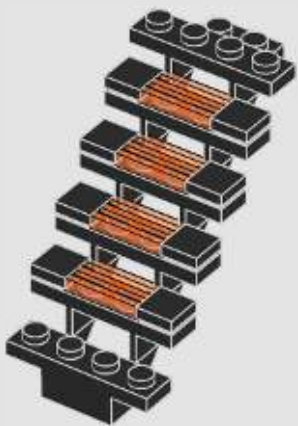



183

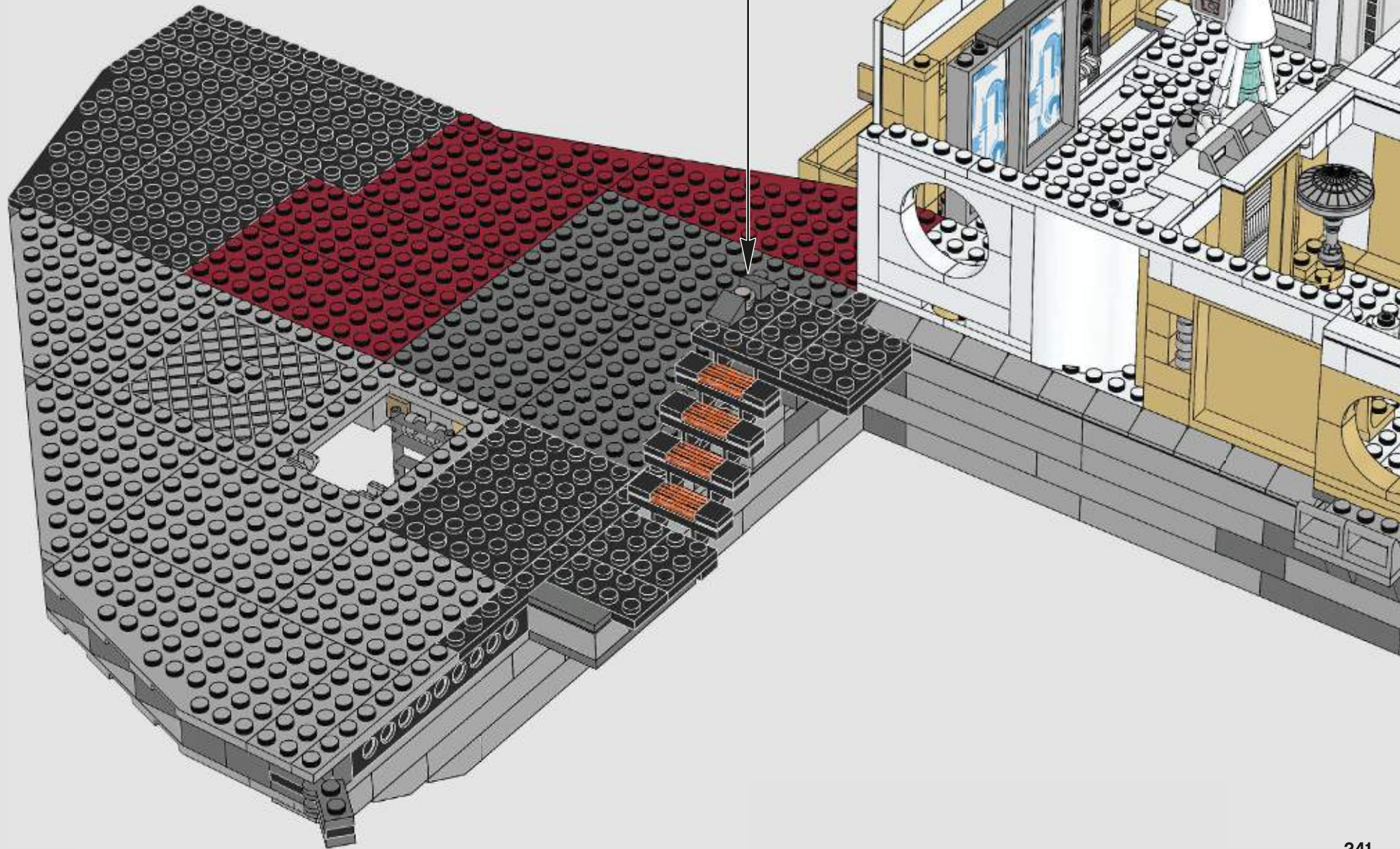

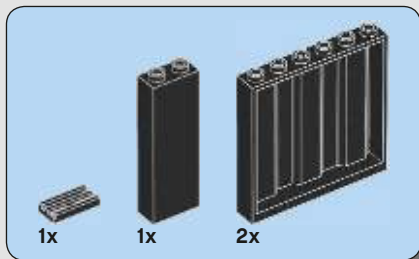

184

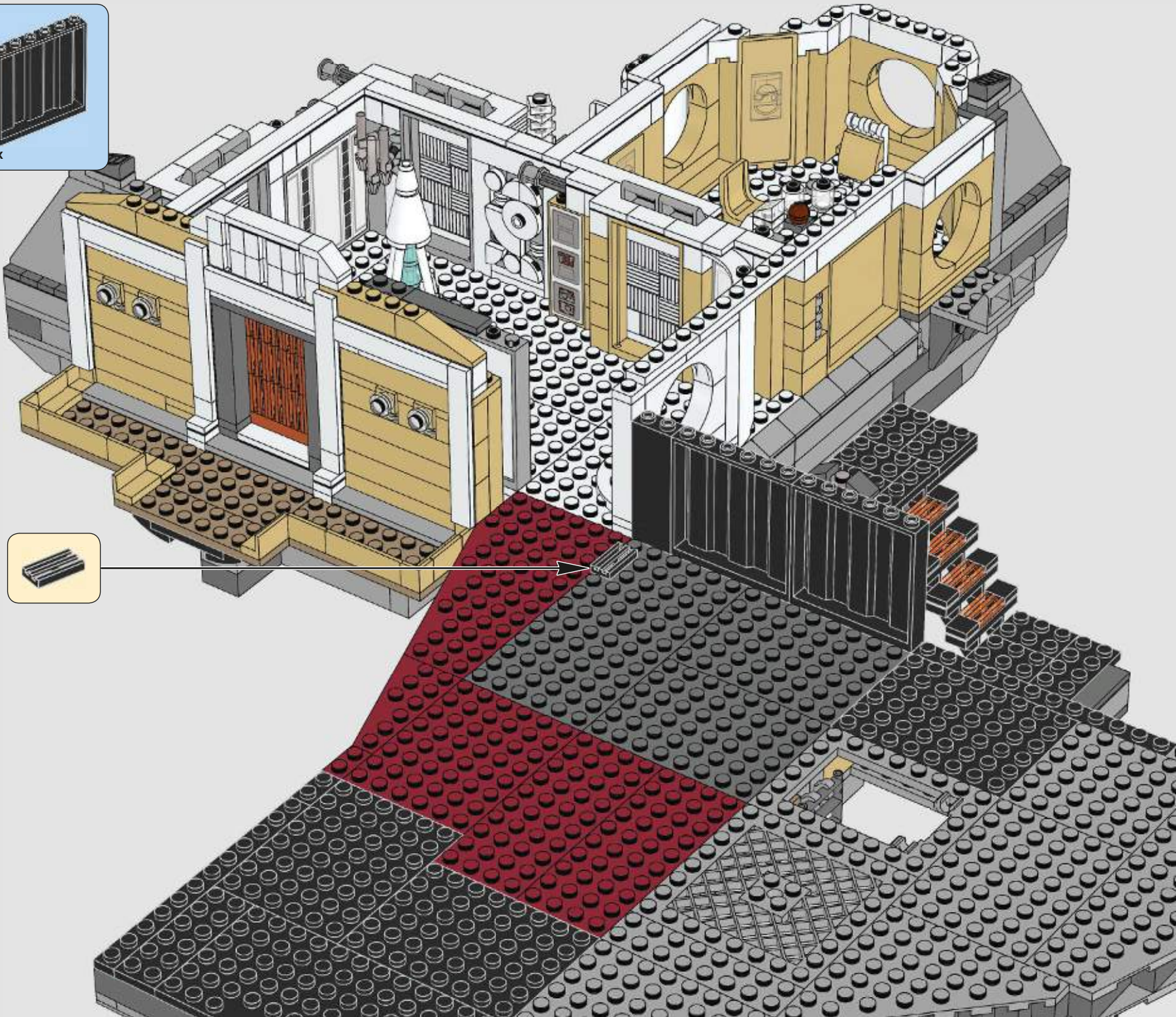

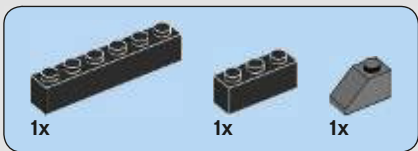

185

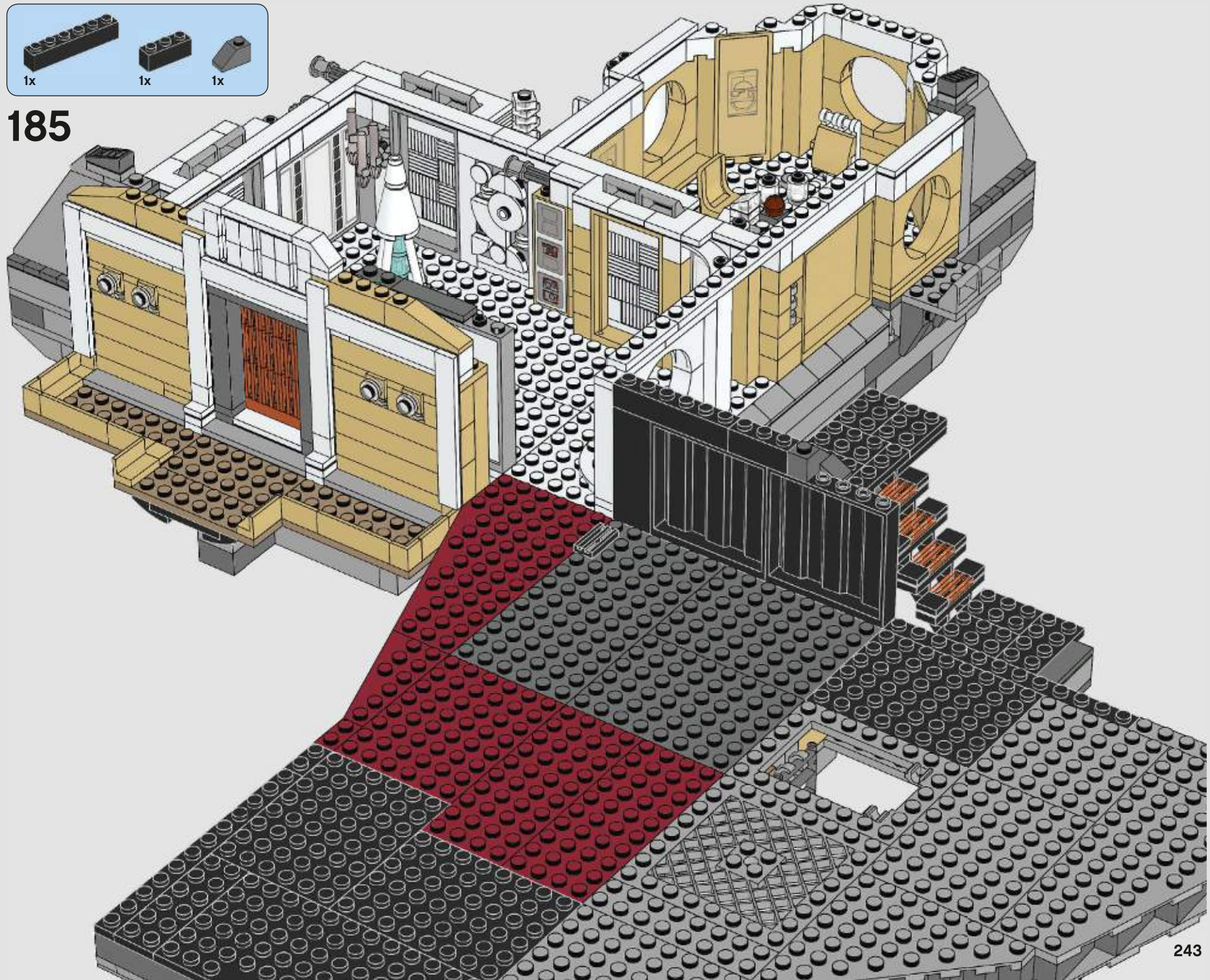

- 1x
- 1x
- 1x
- 1x

186

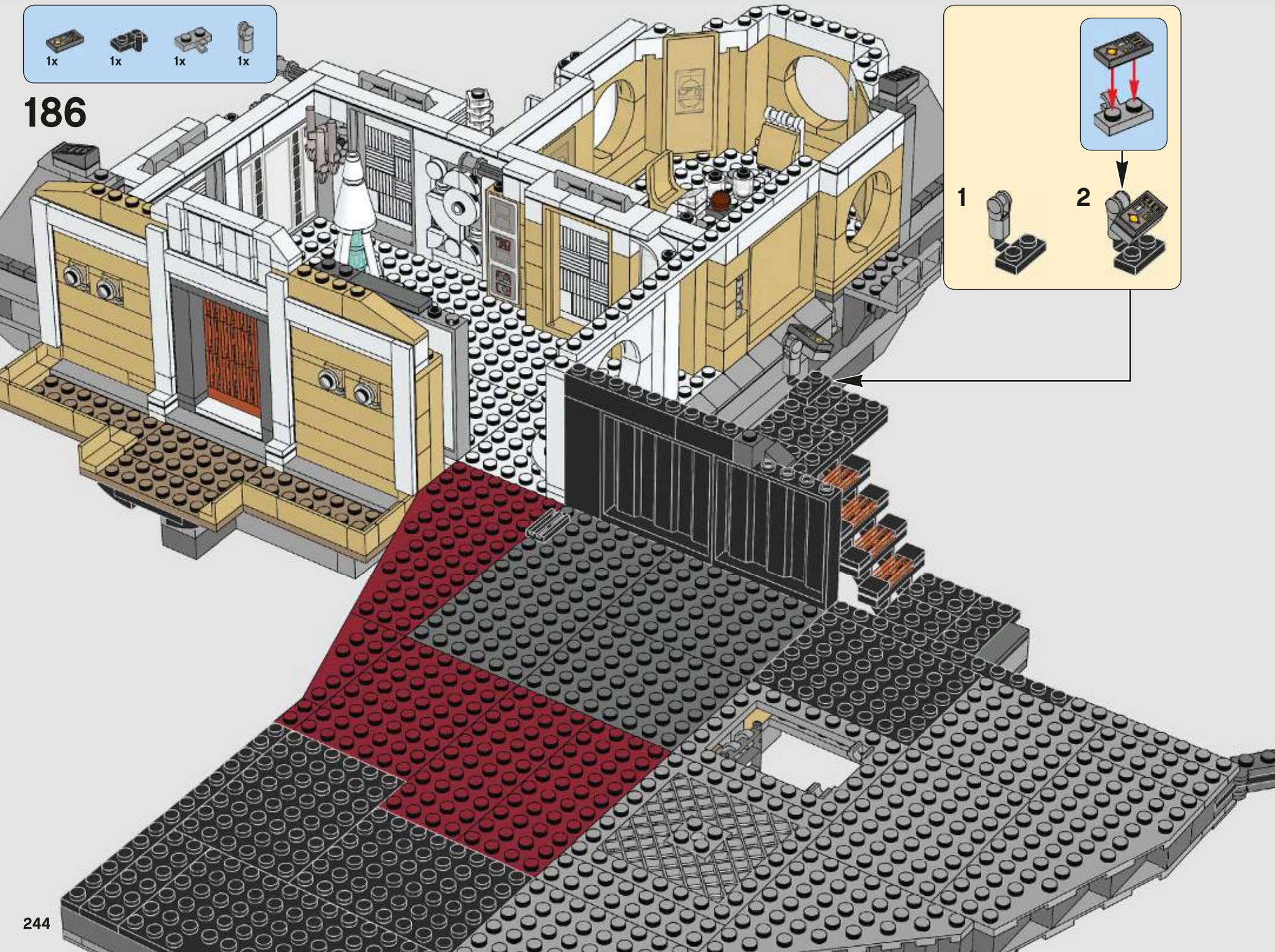

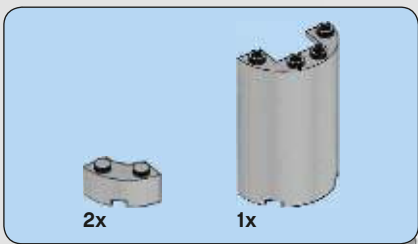

187

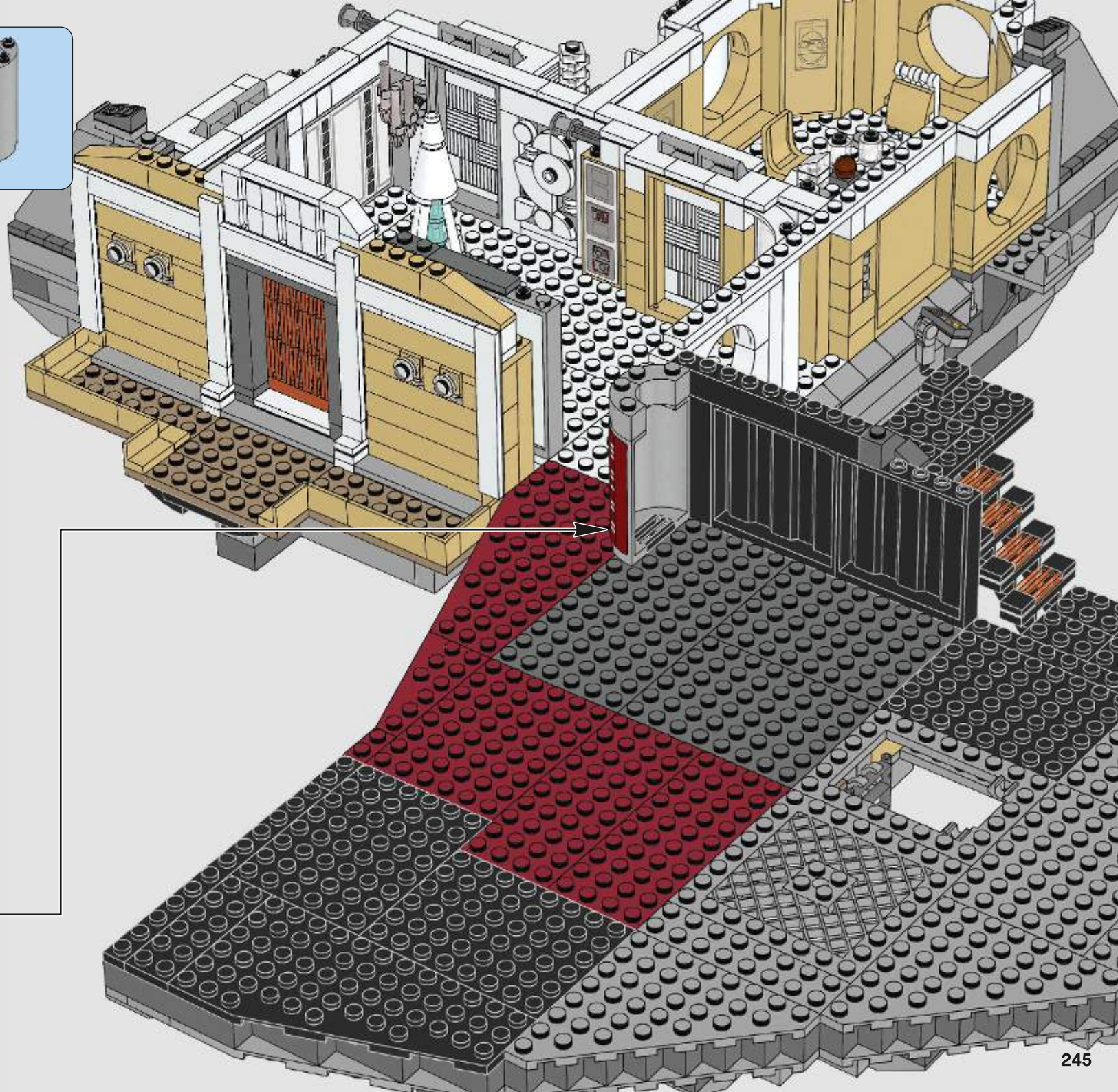
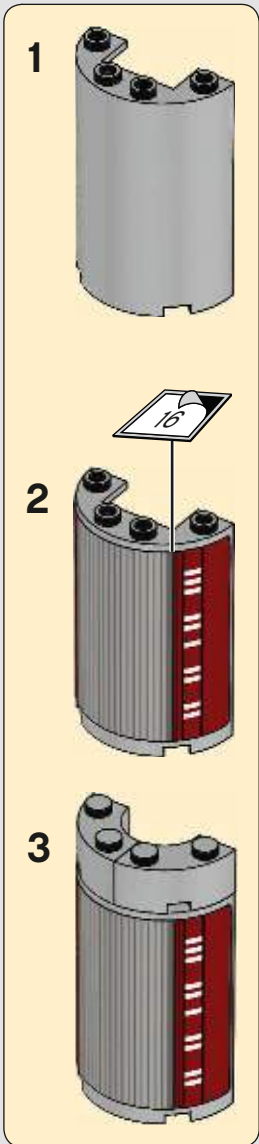

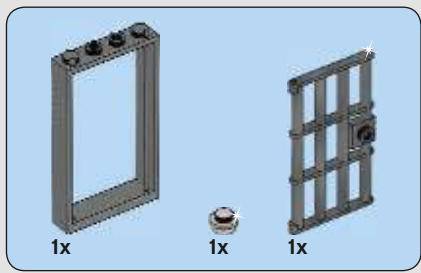

188

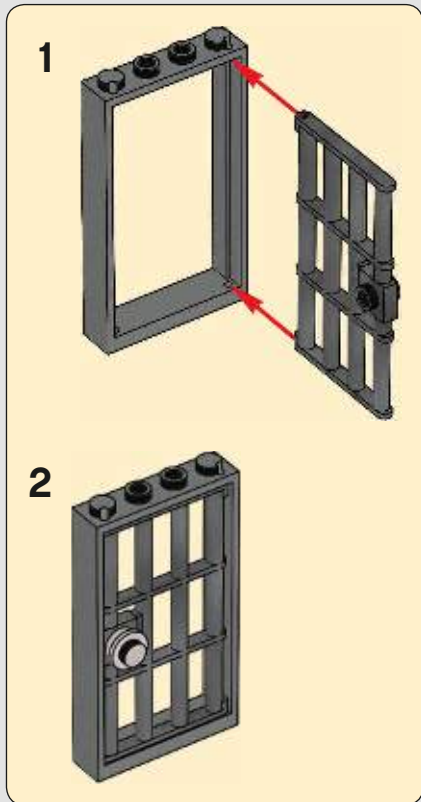
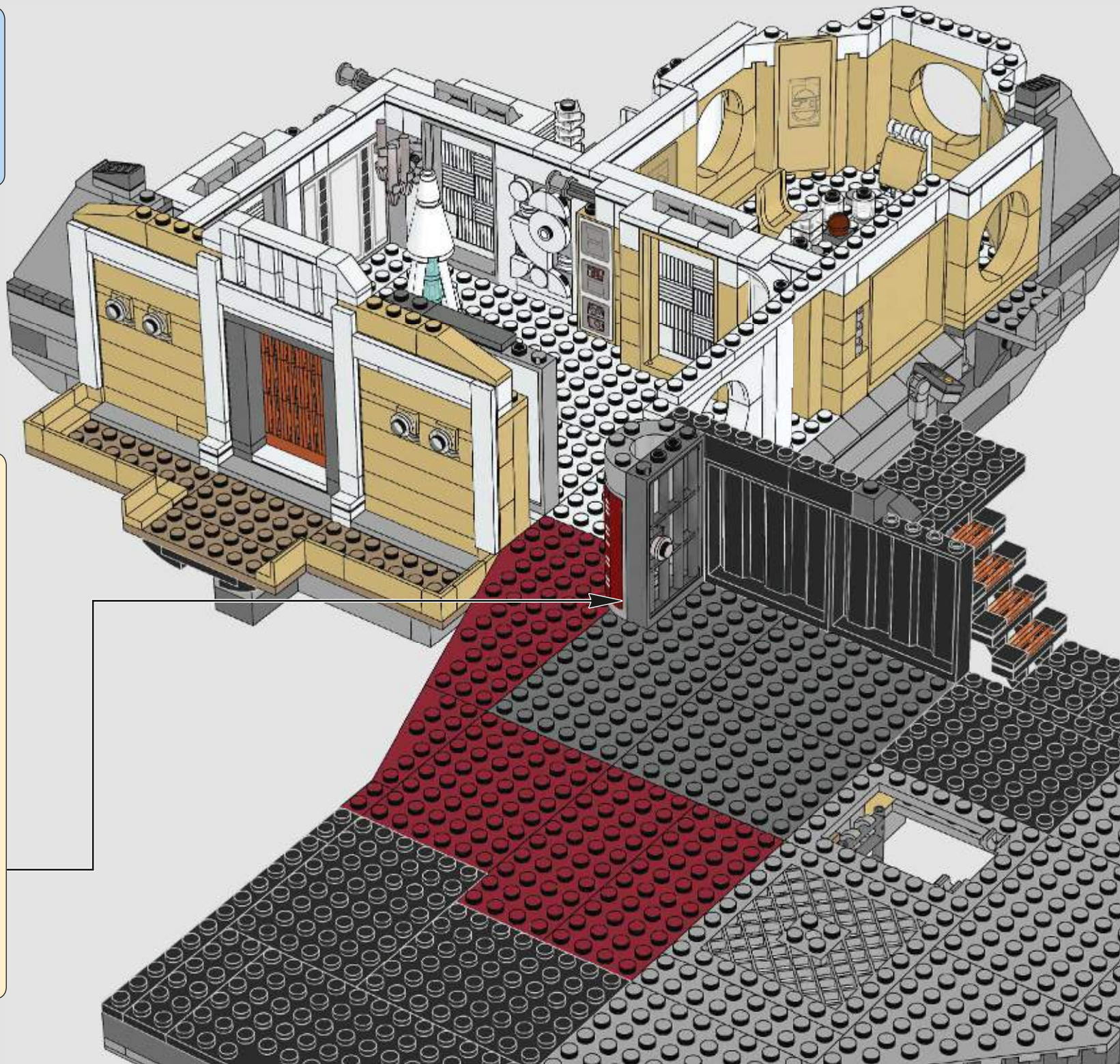

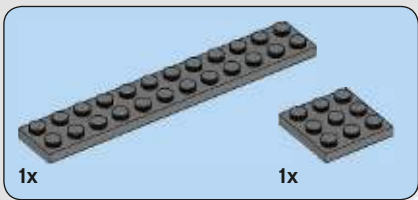

189

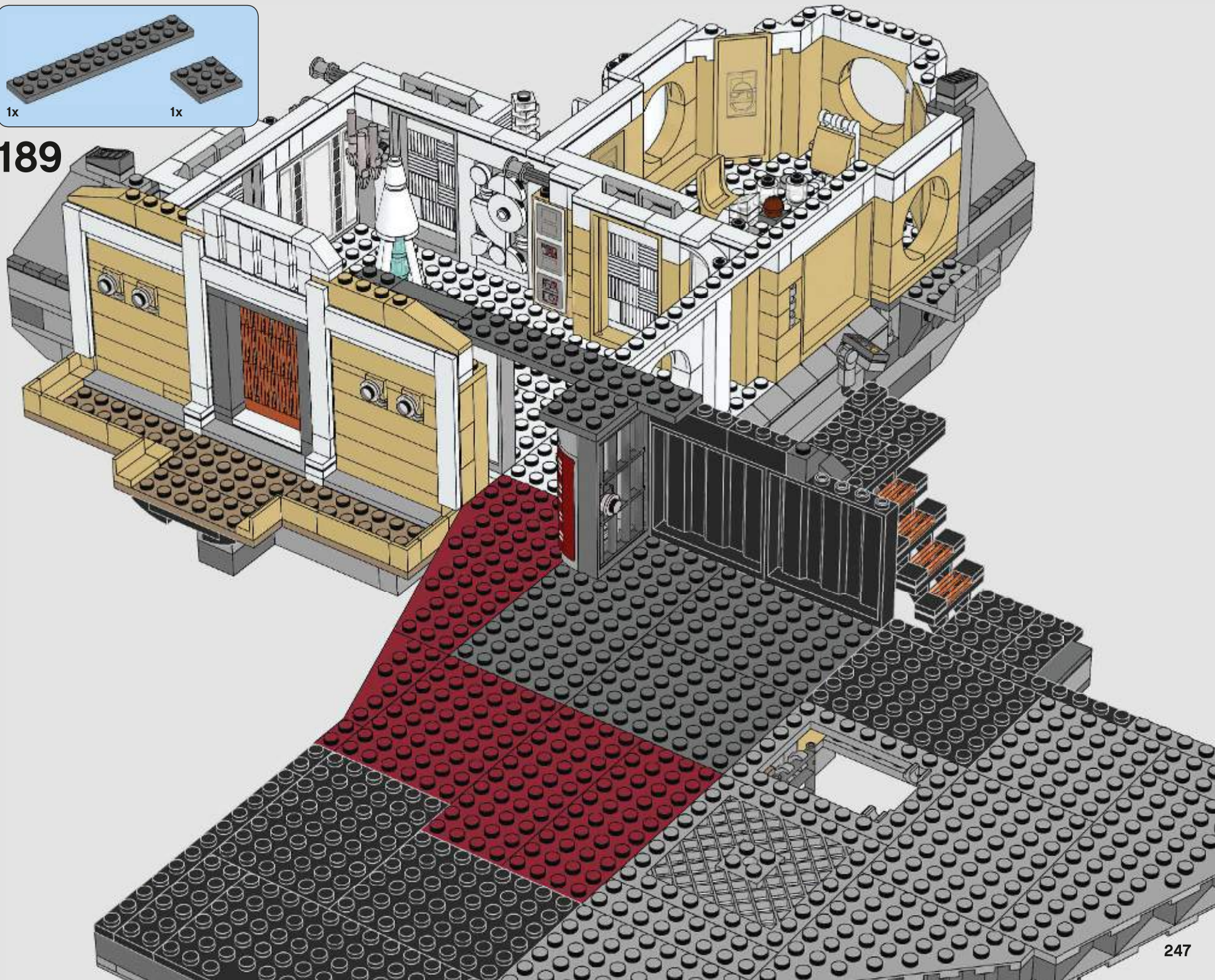

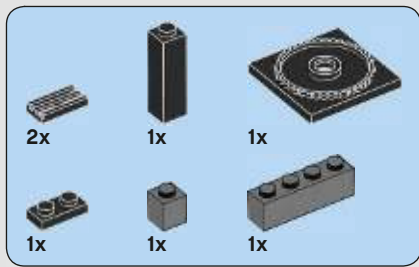

190

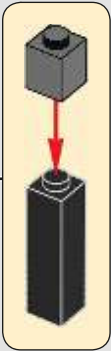
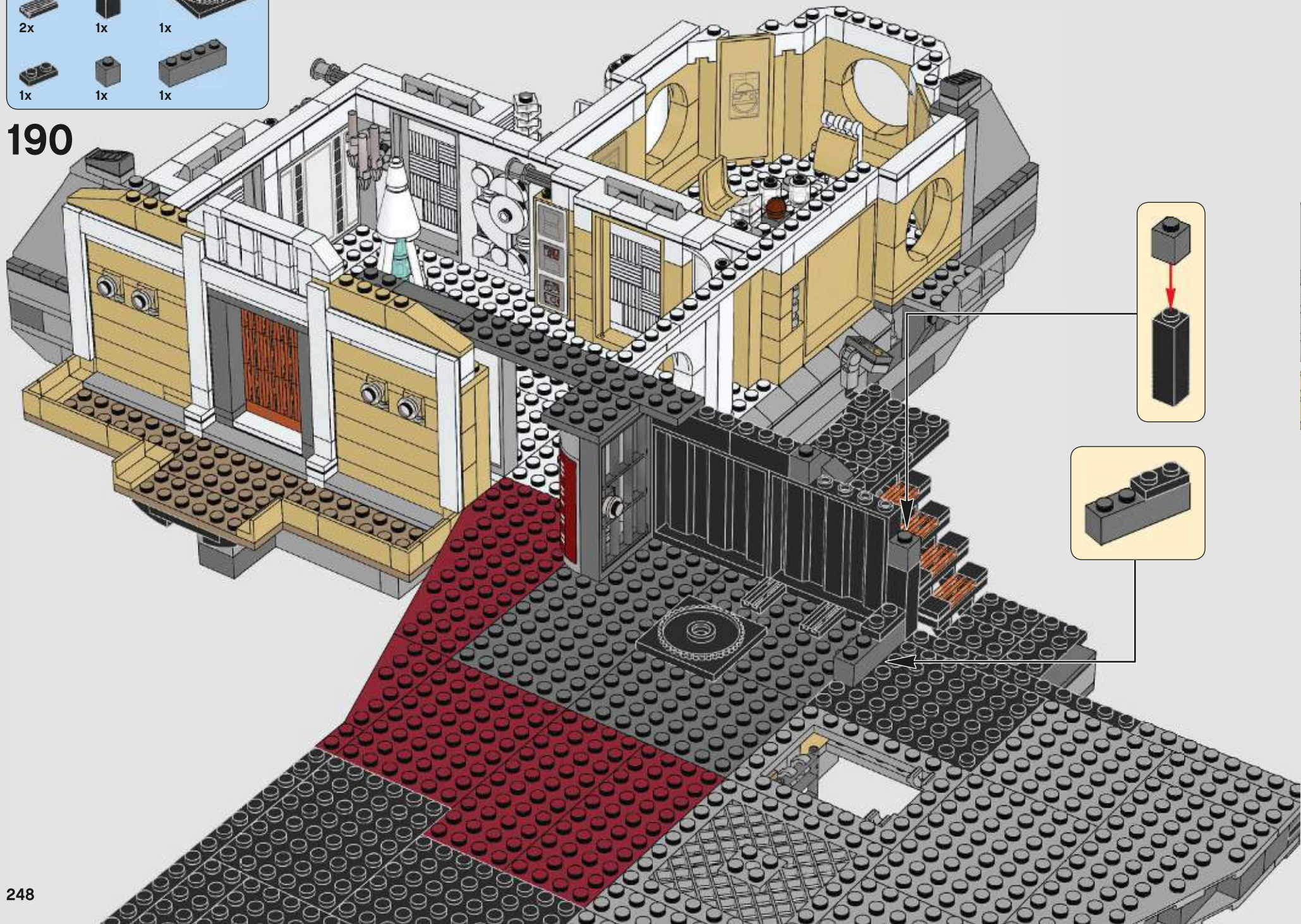

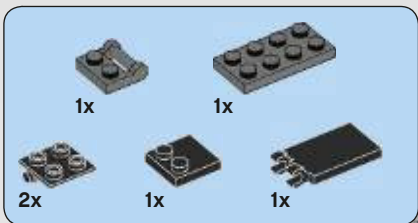

191

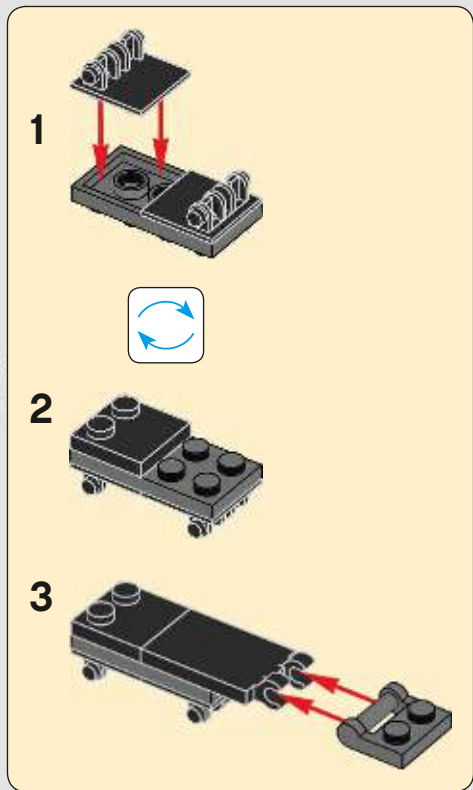
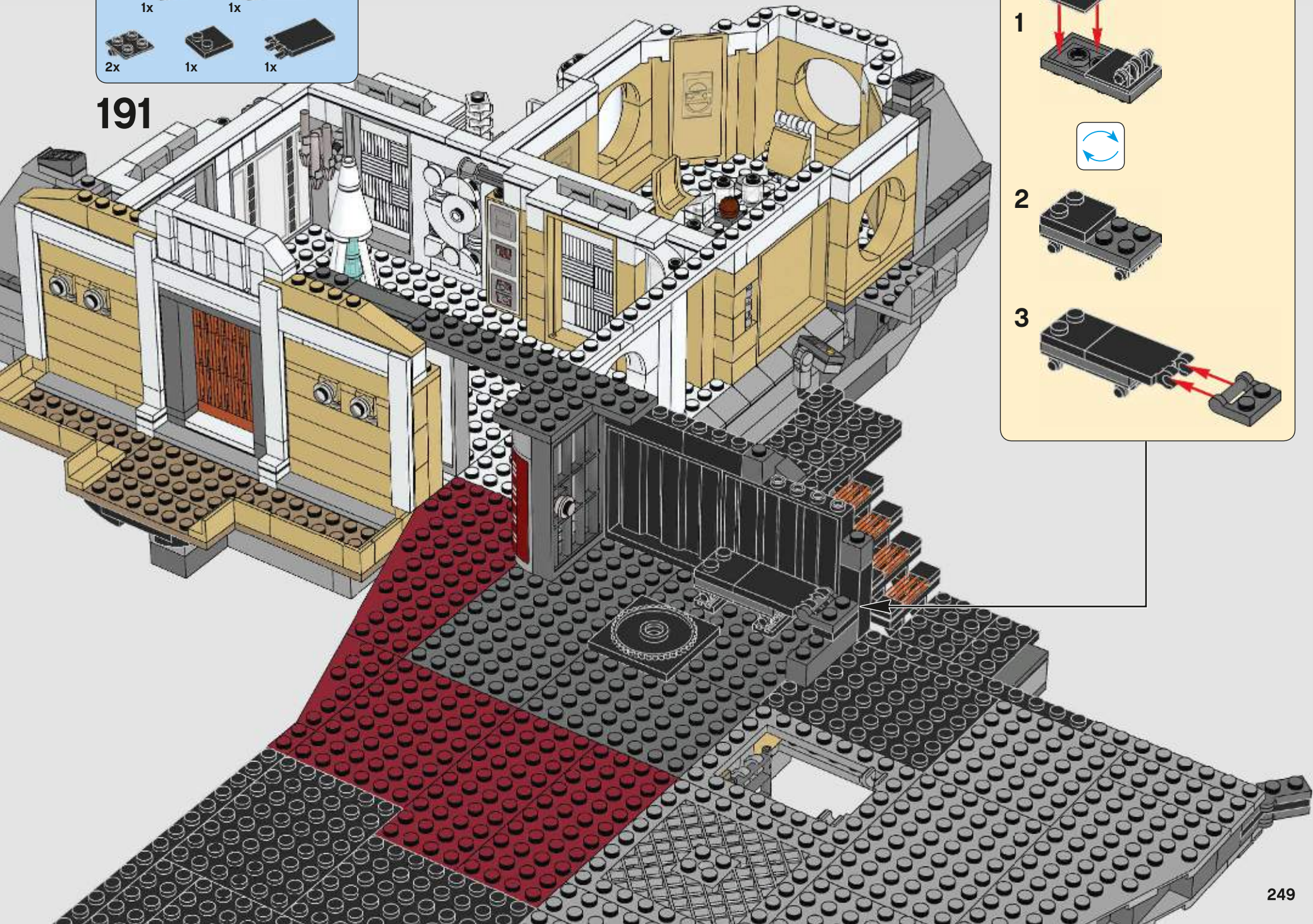



192

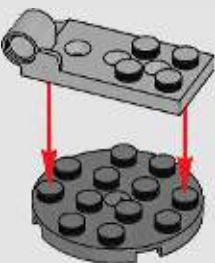

193

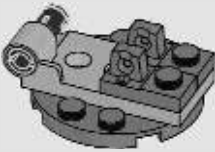

194

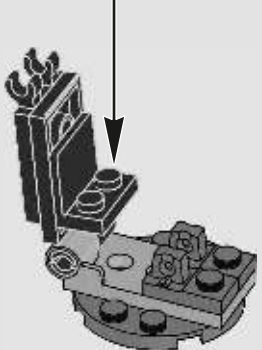

195

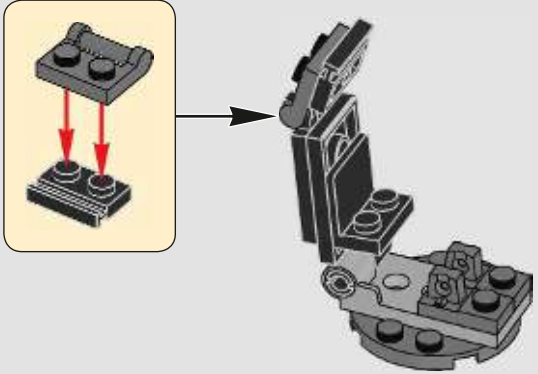

196

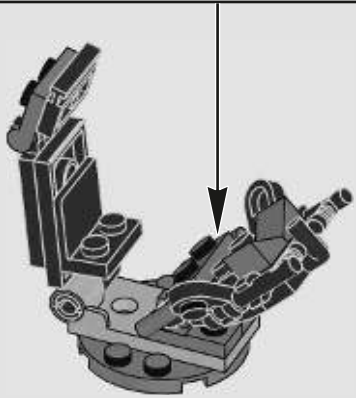
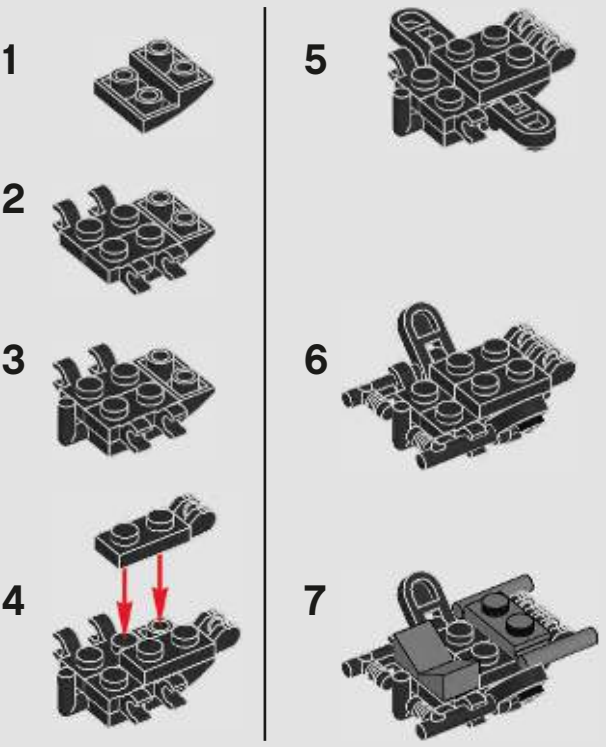

197

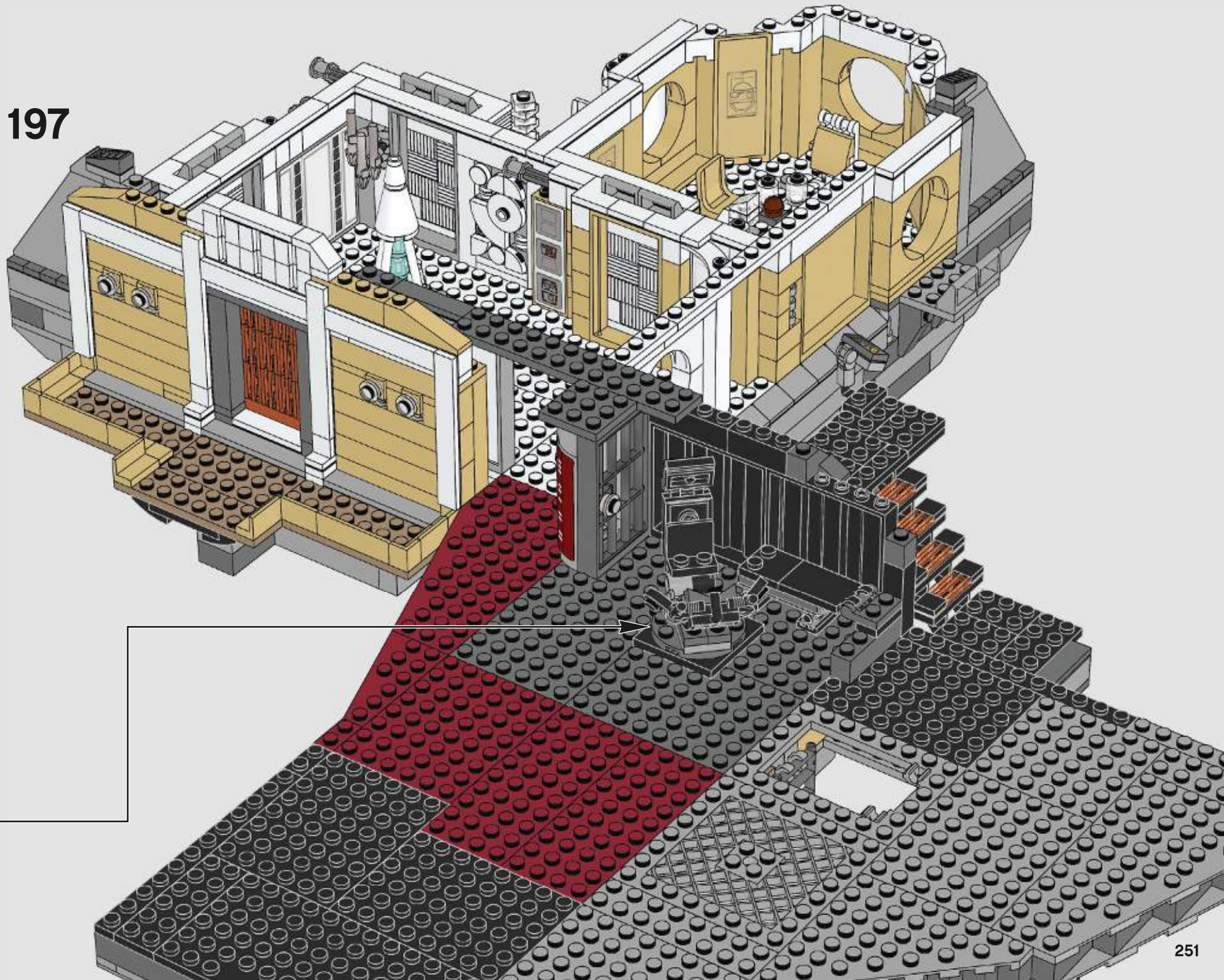

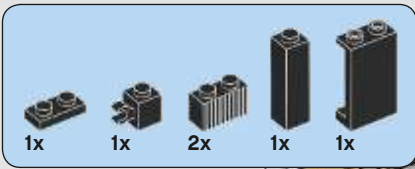

198

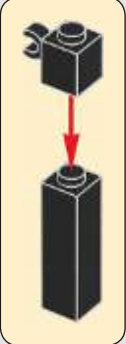
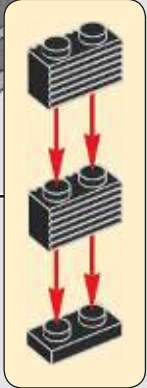
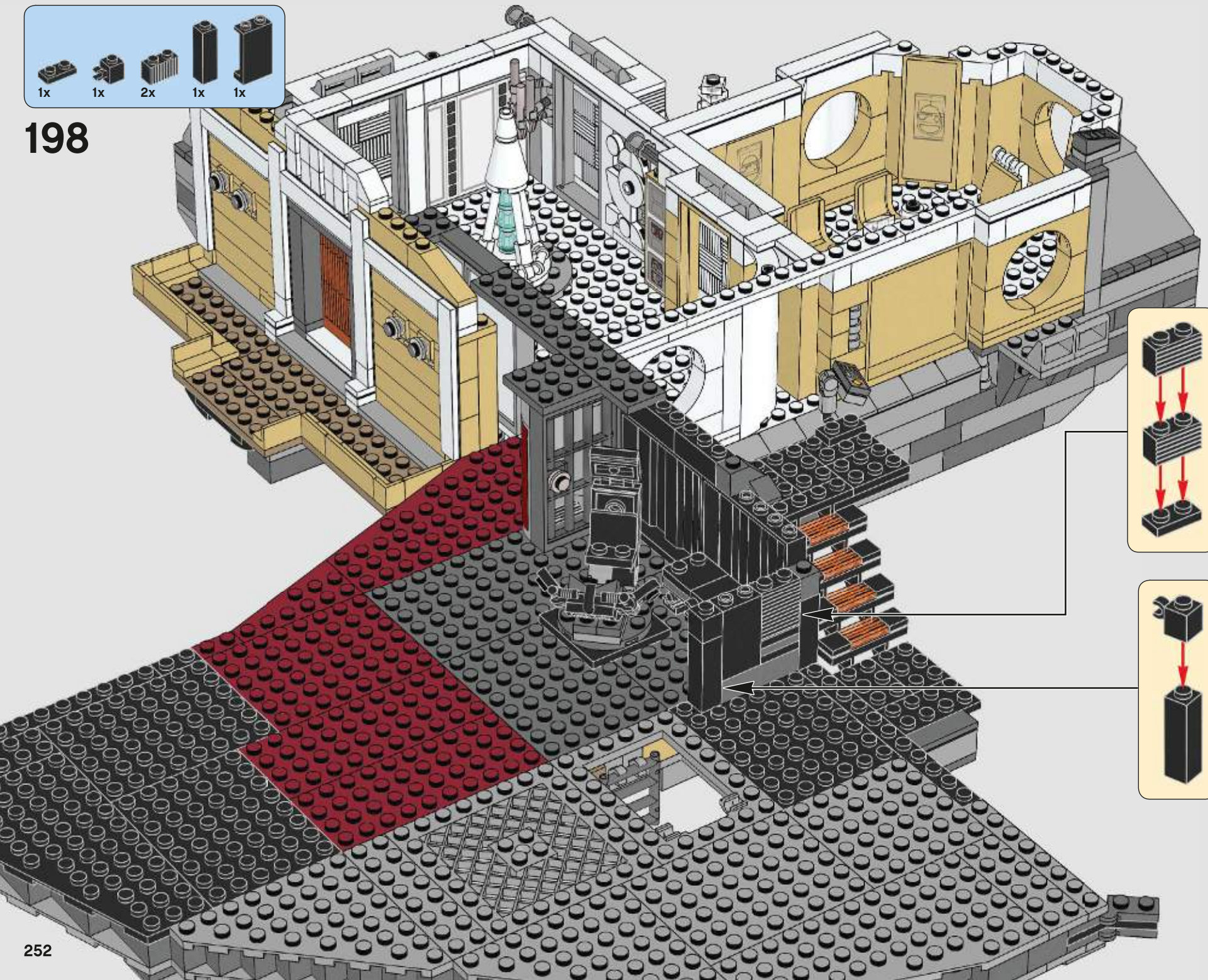

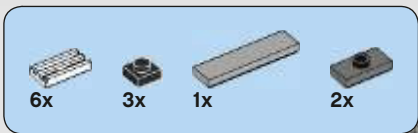

199

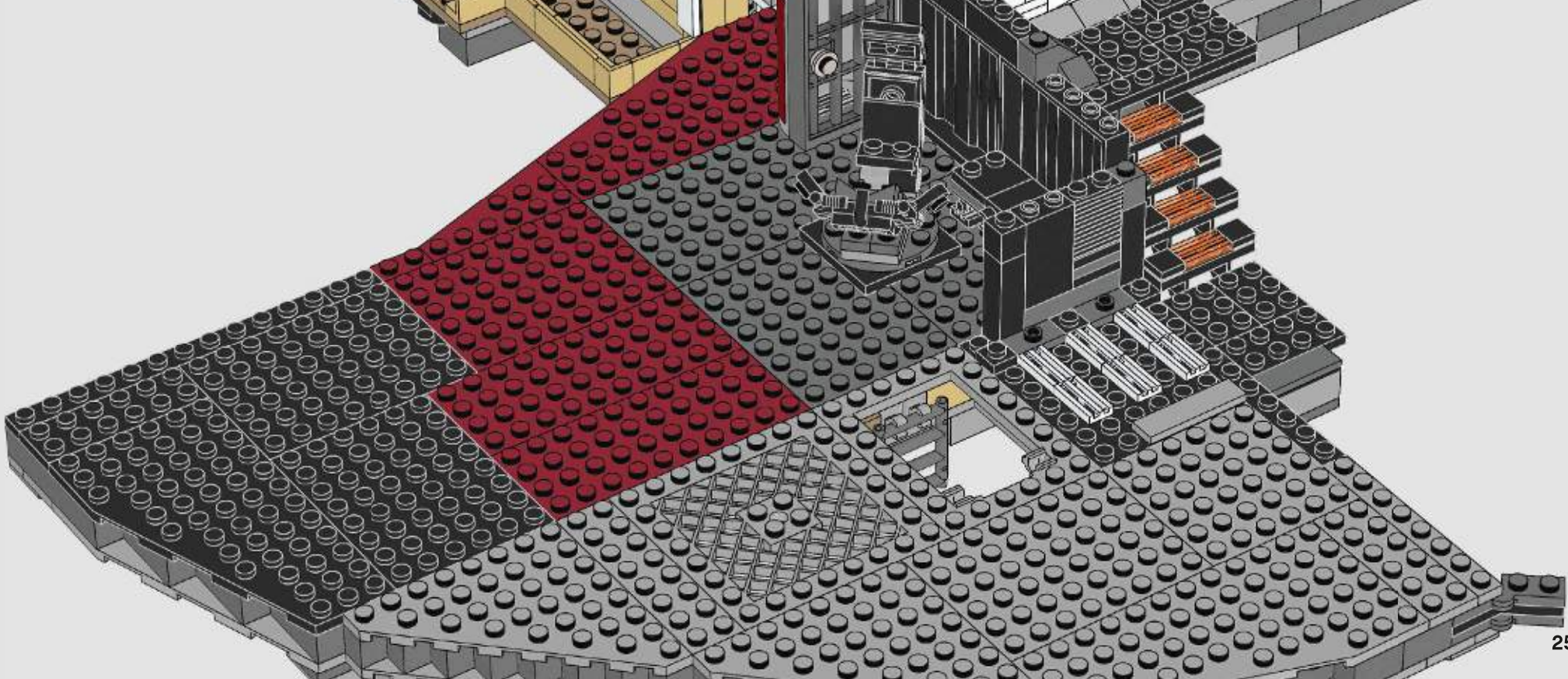
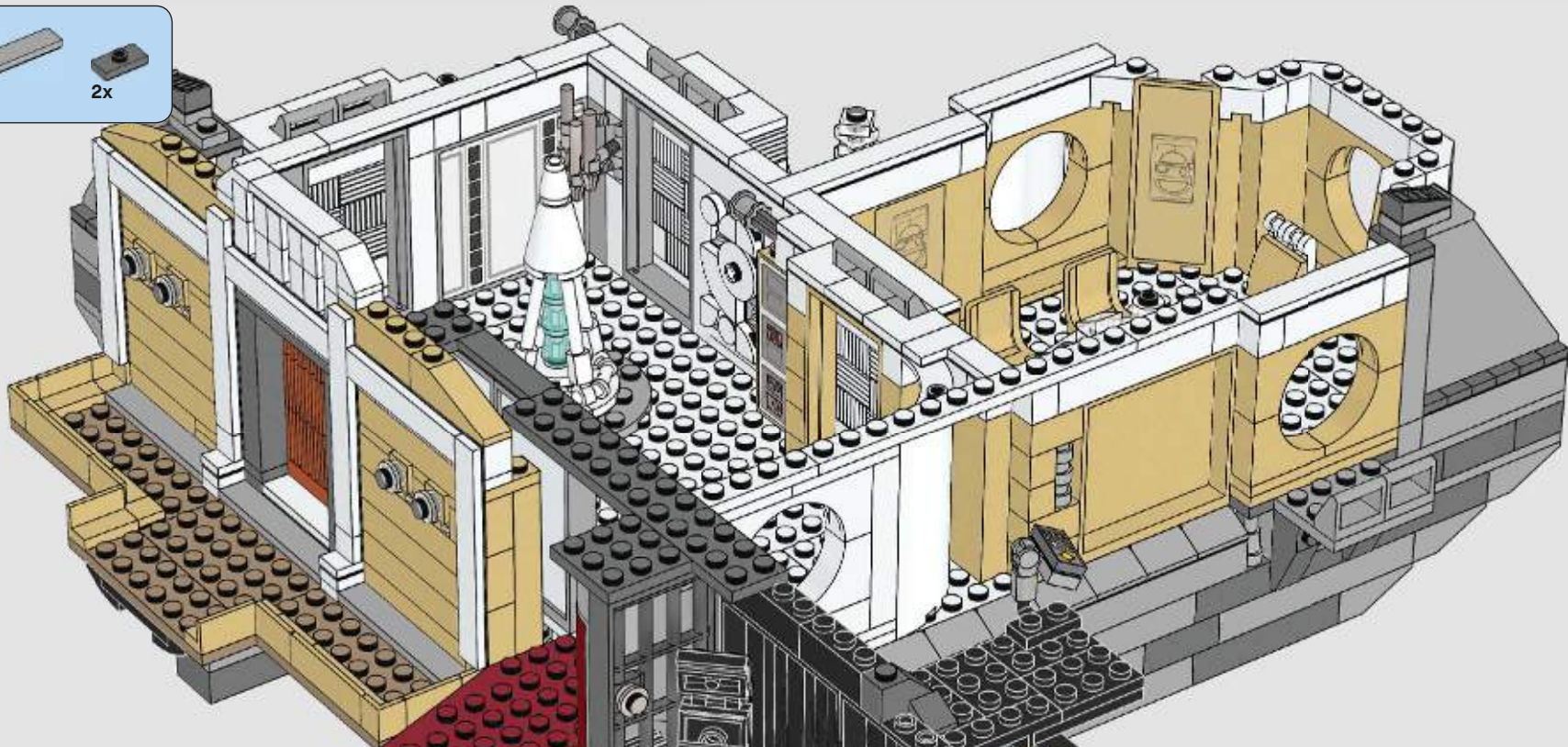

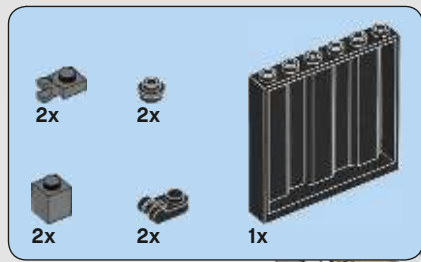

200

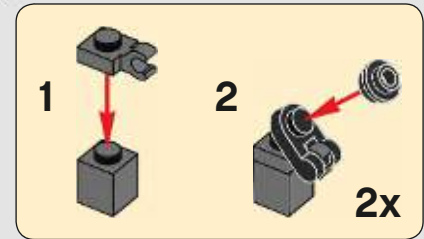
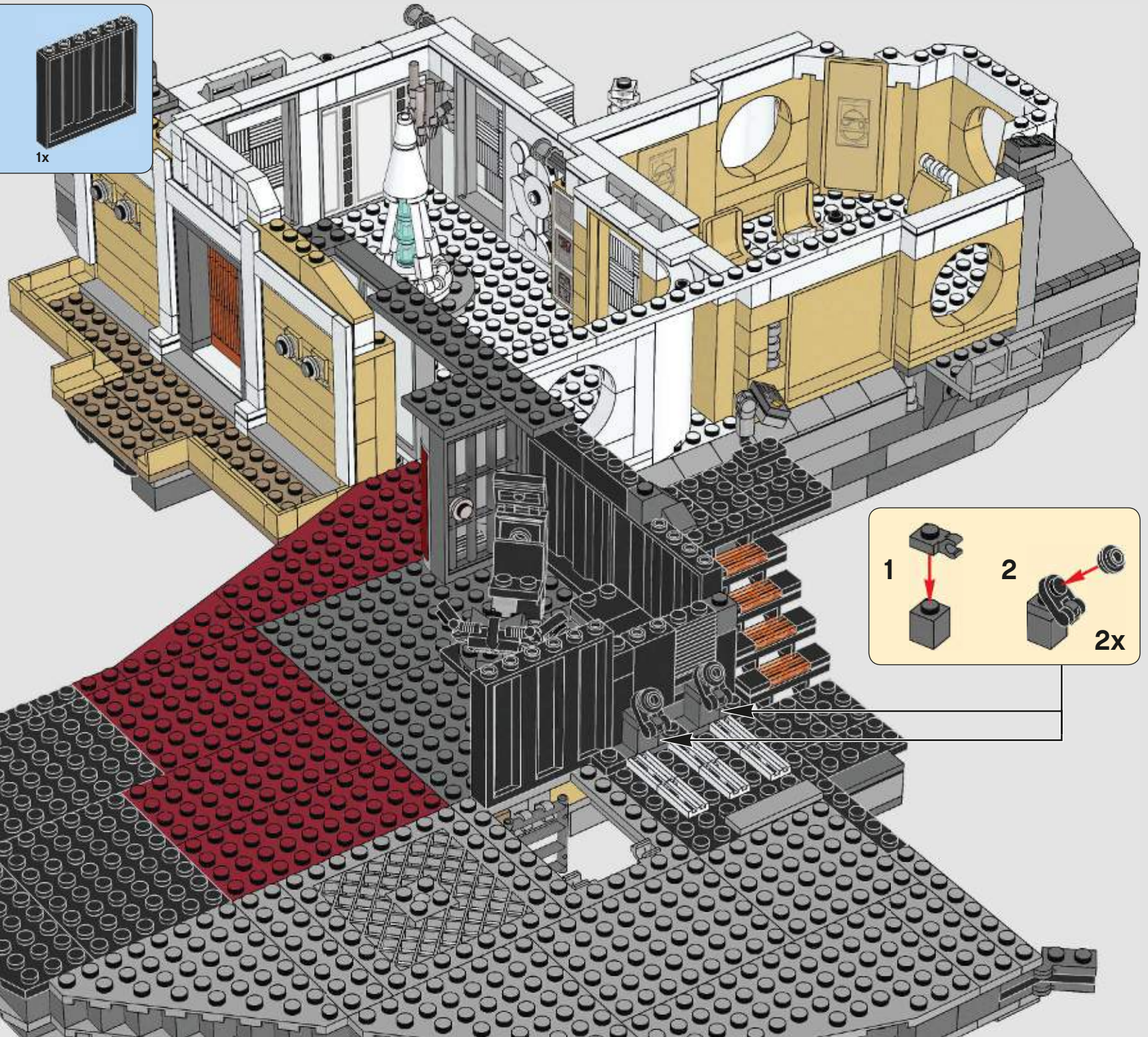

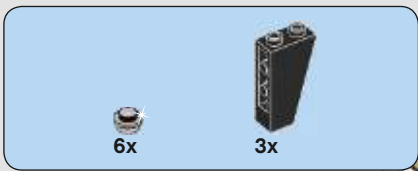



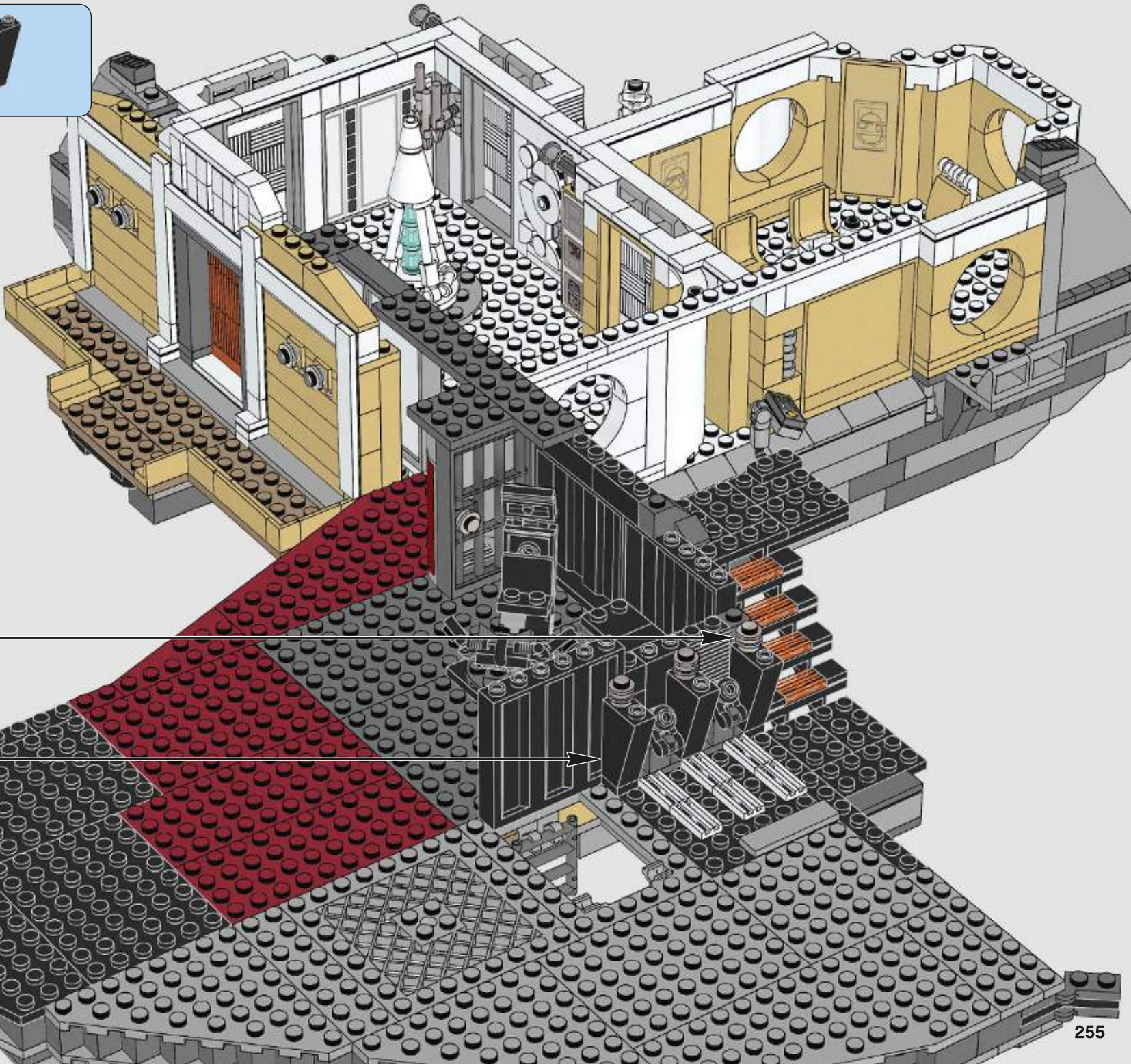
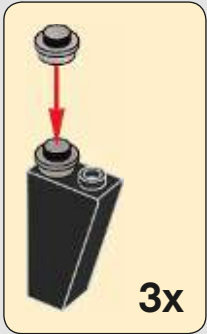

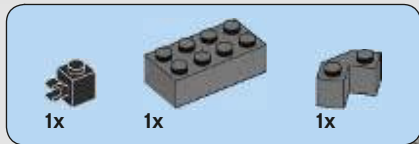

201

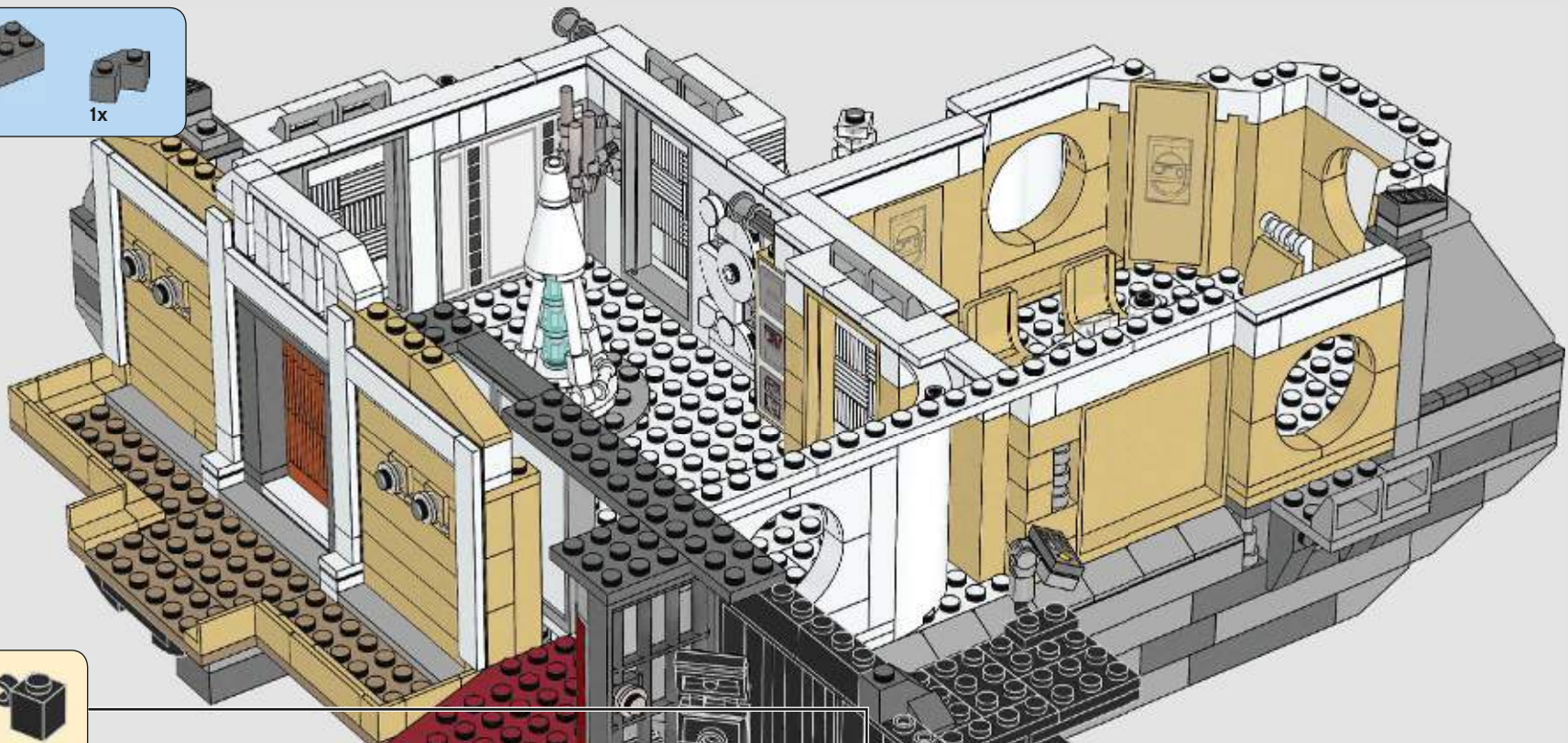



202



- 4x 
- 3x 
- 1x 
- 1x 
- 1x 
- 3x 

203

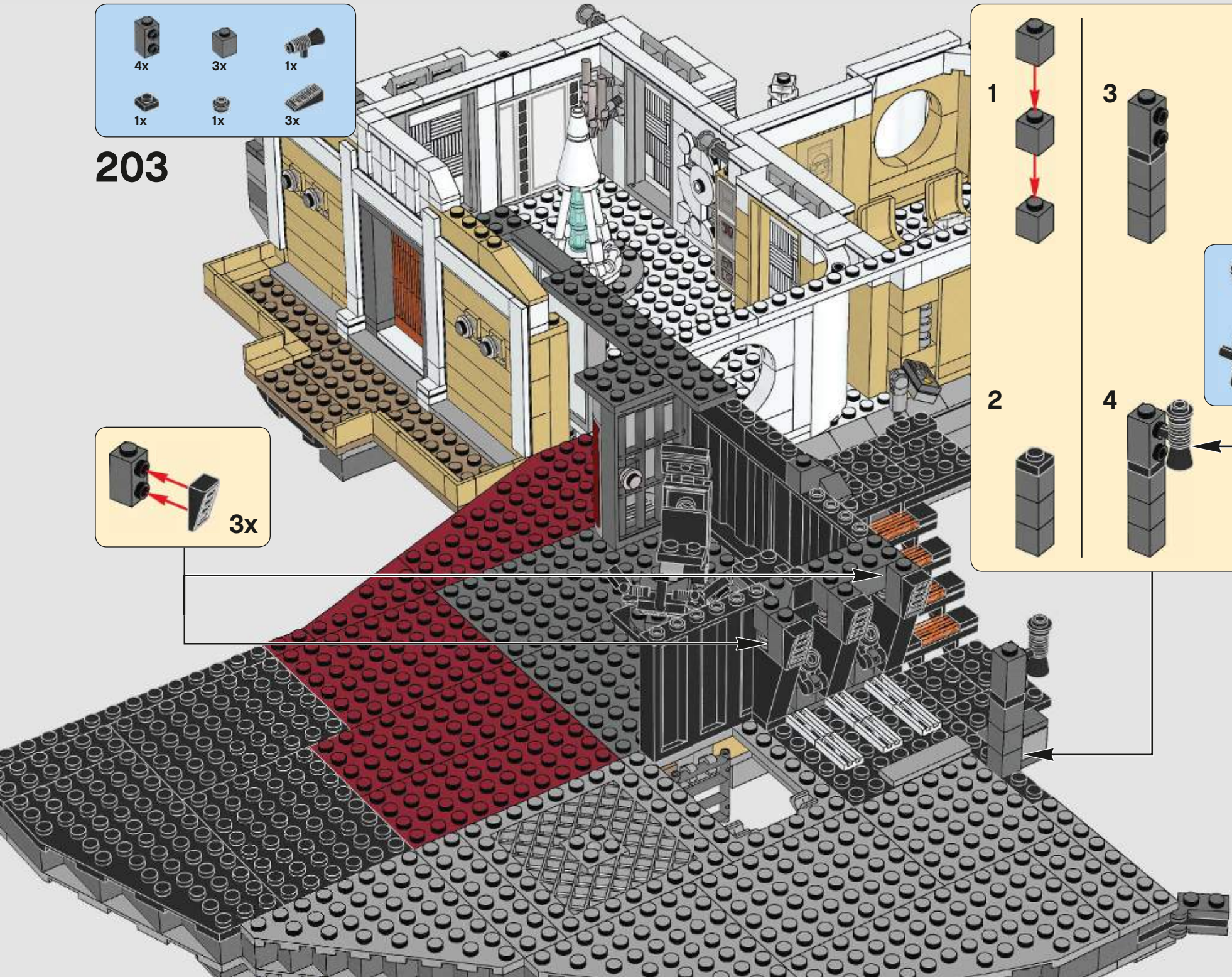
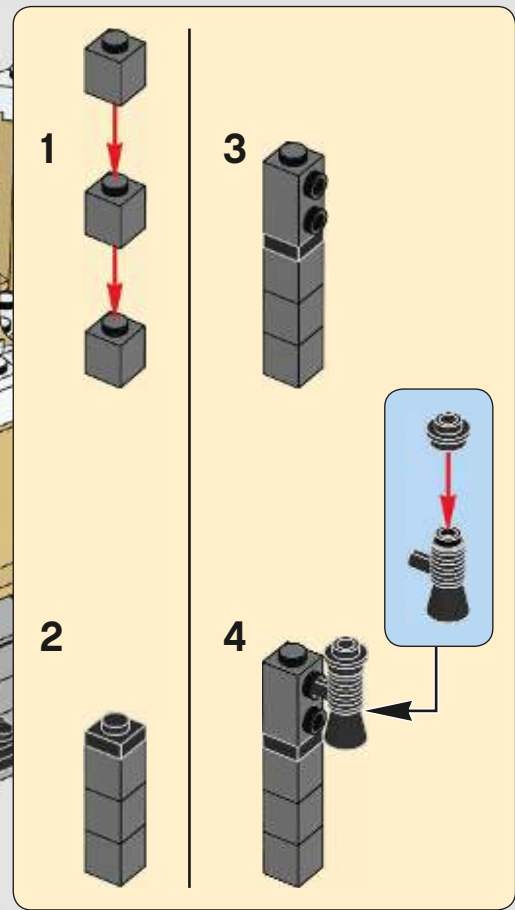
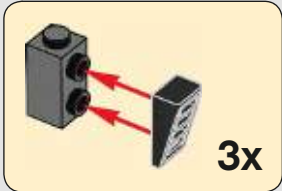

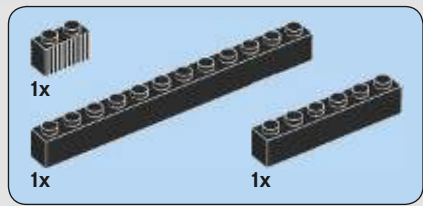

204

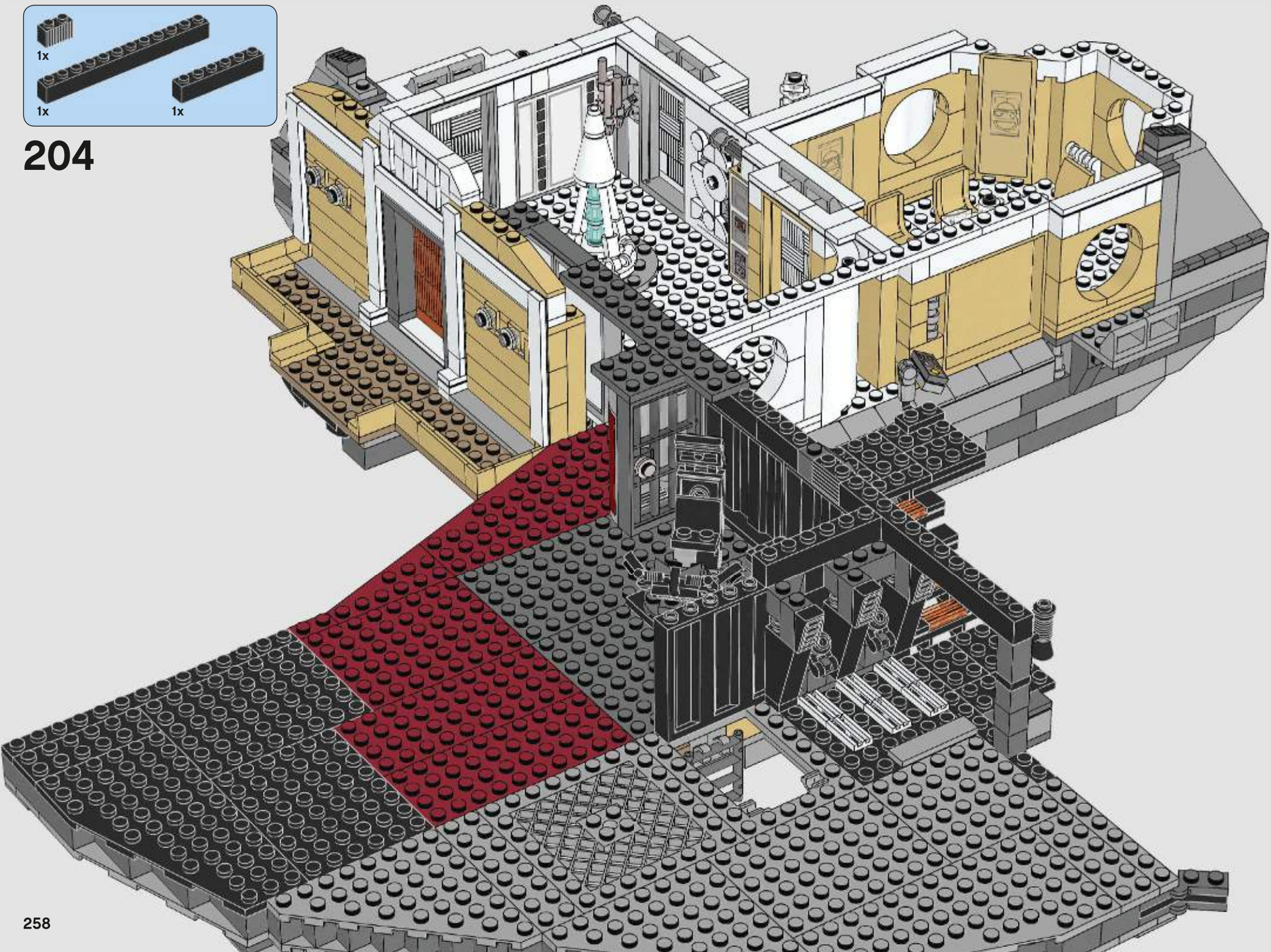

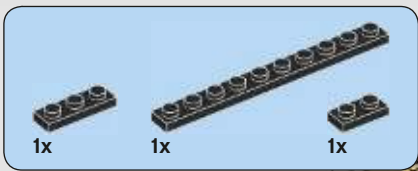

205

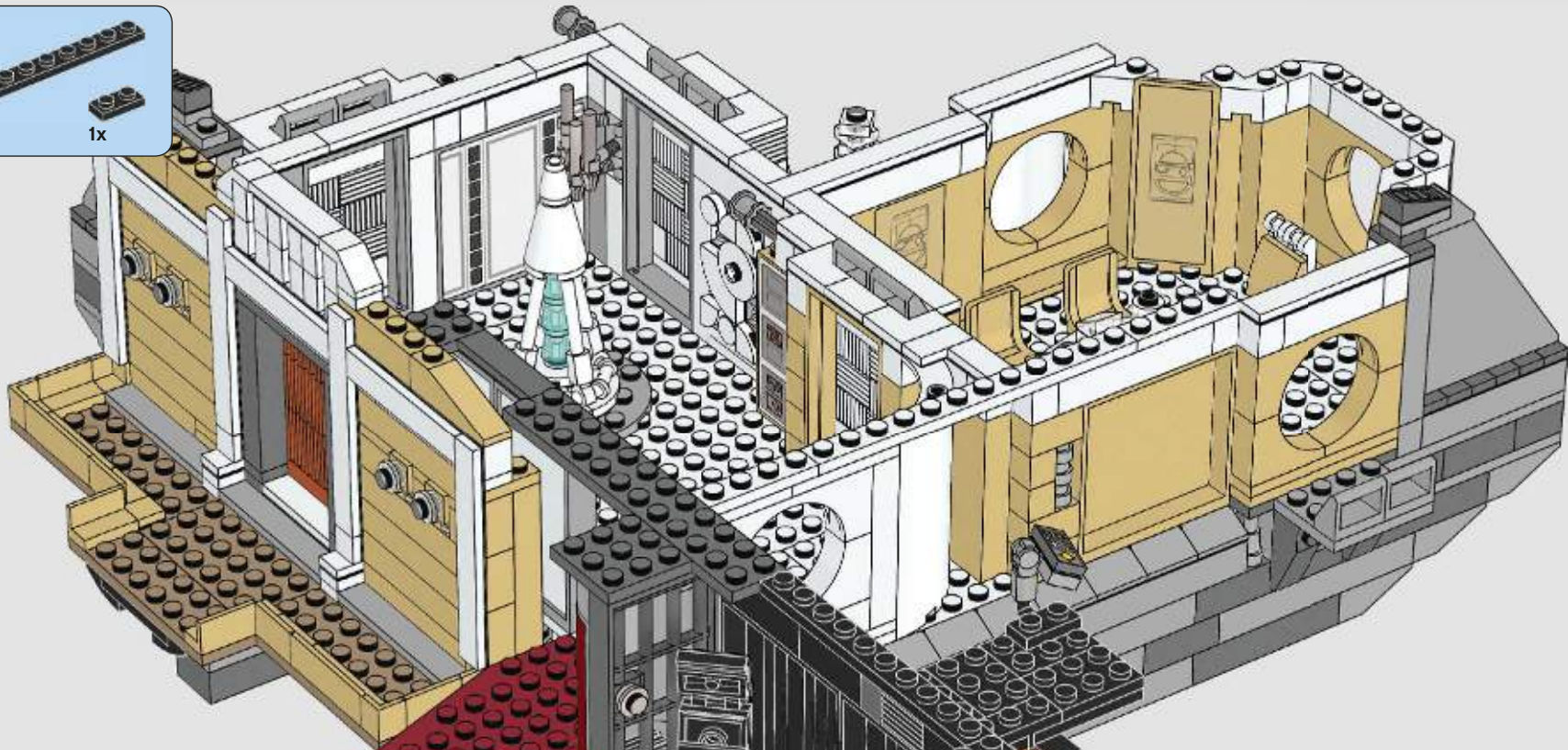

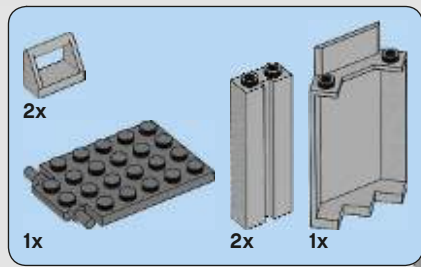

206

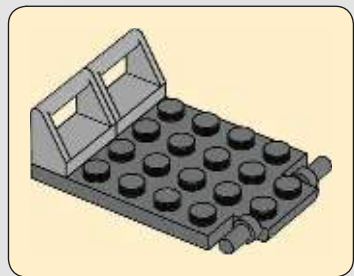
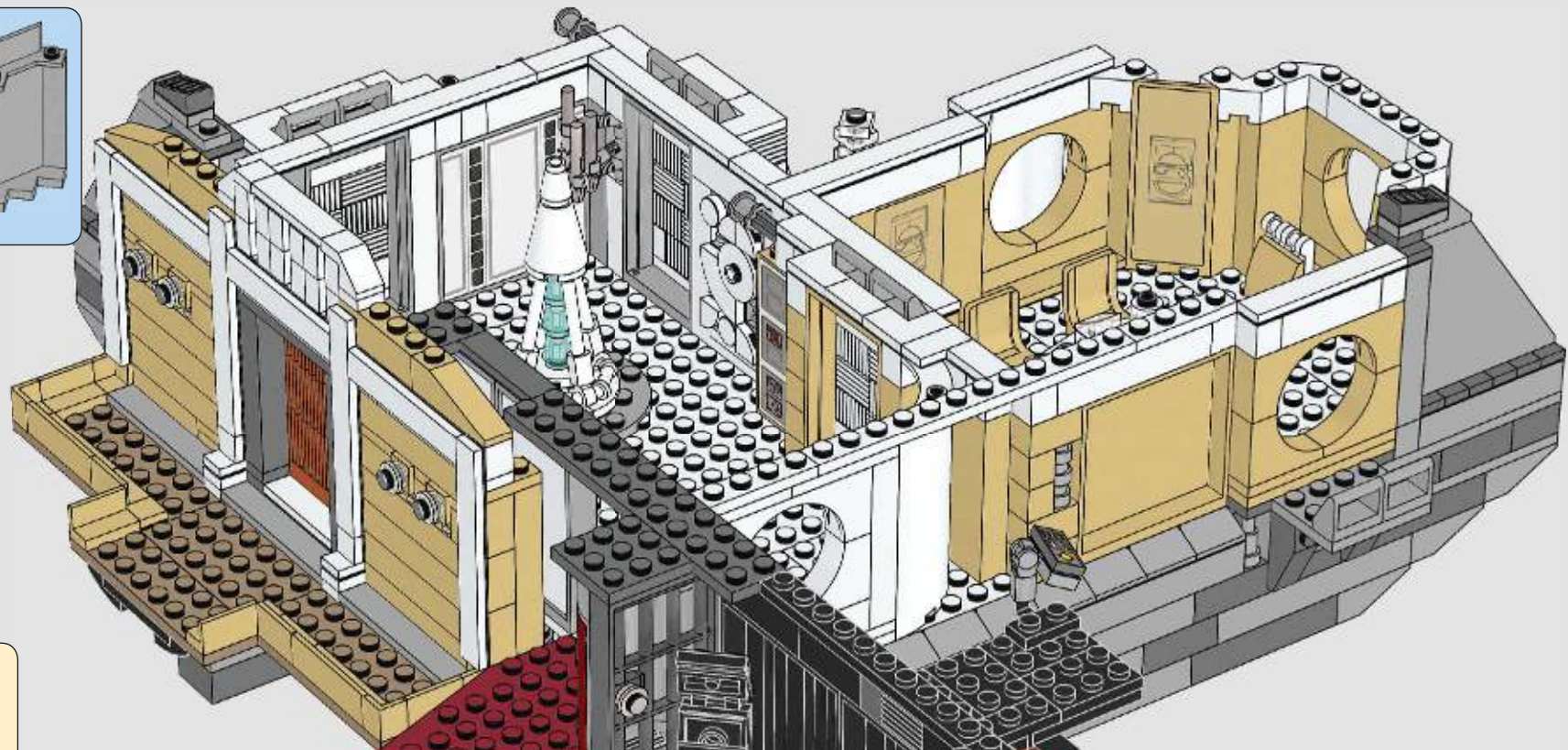

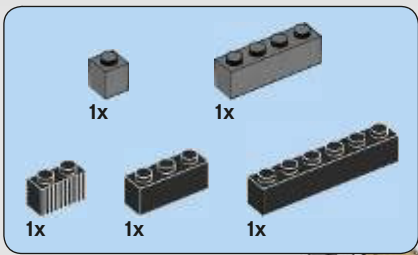

207

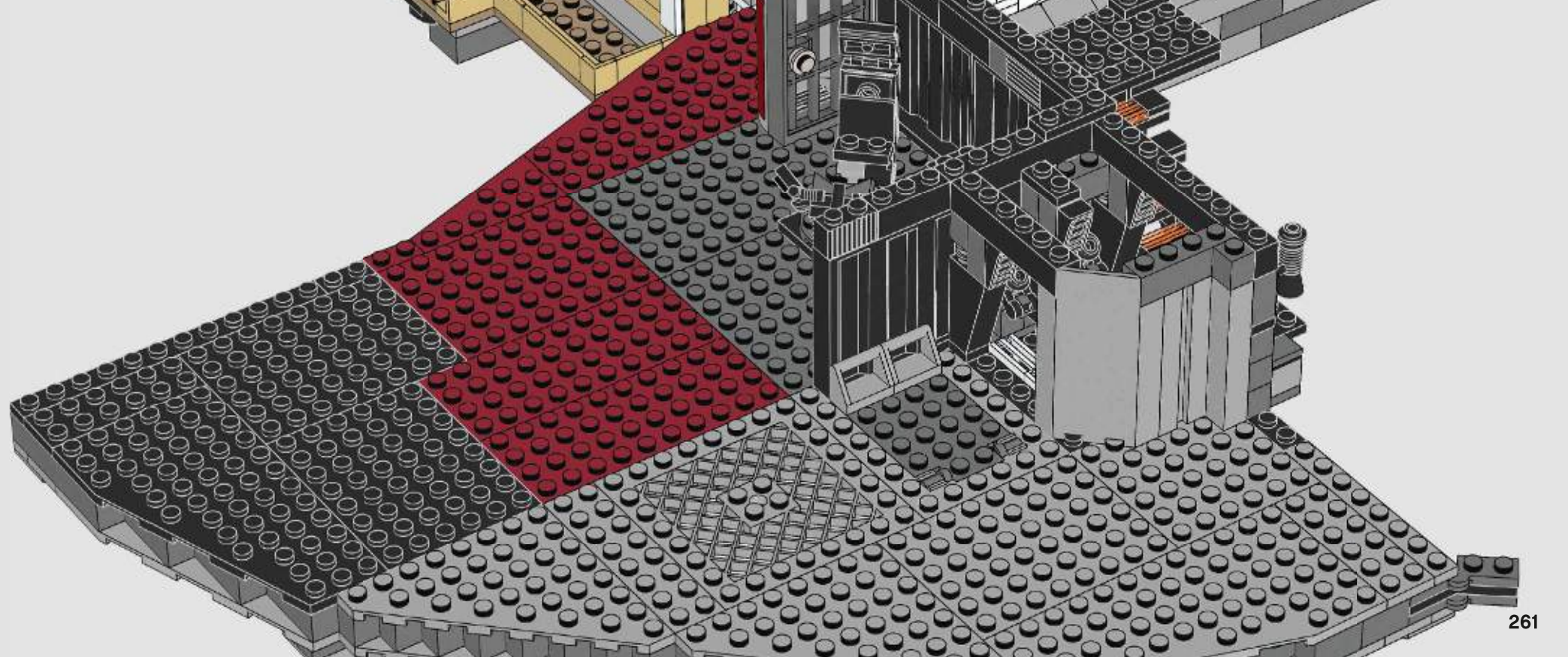
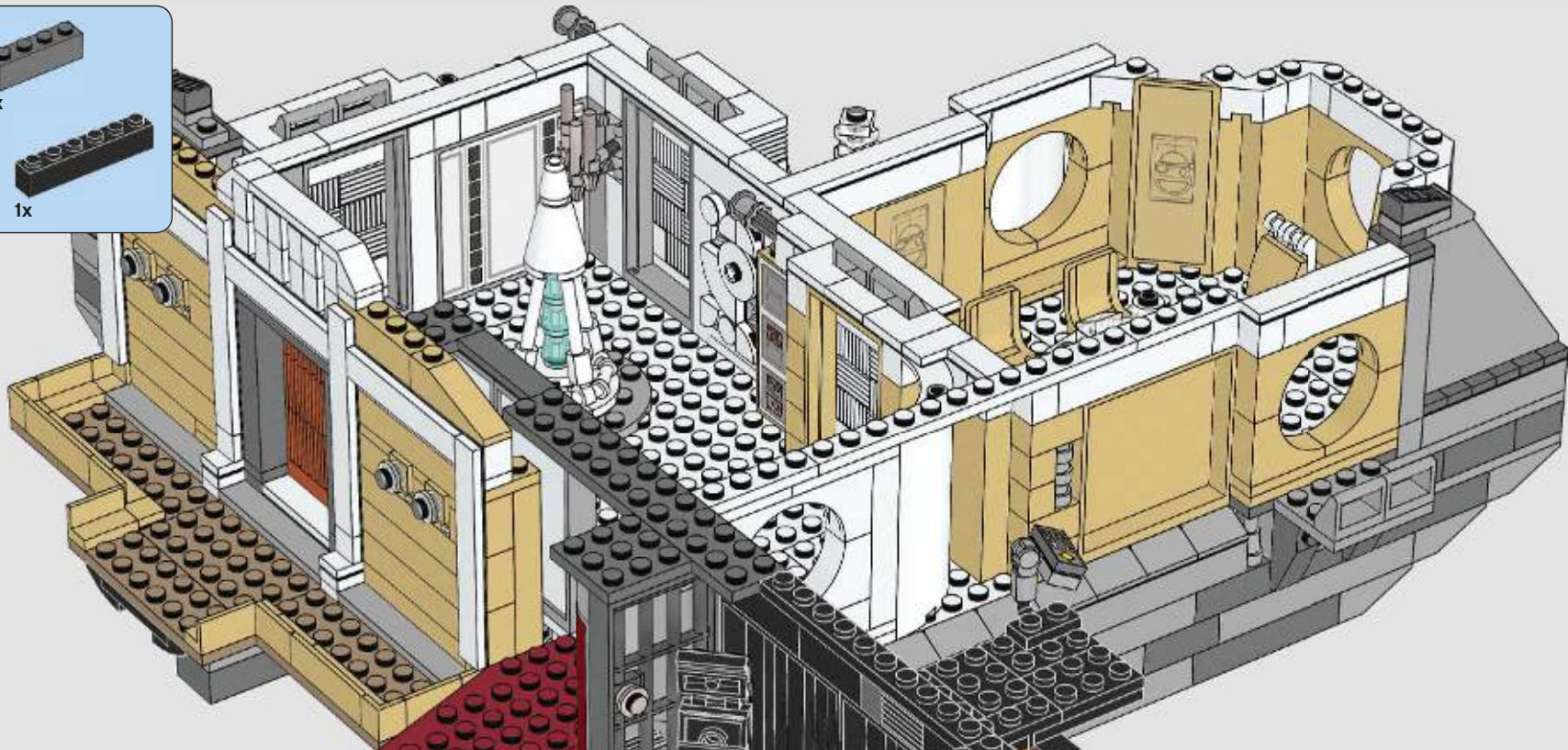

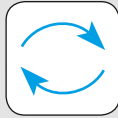

208

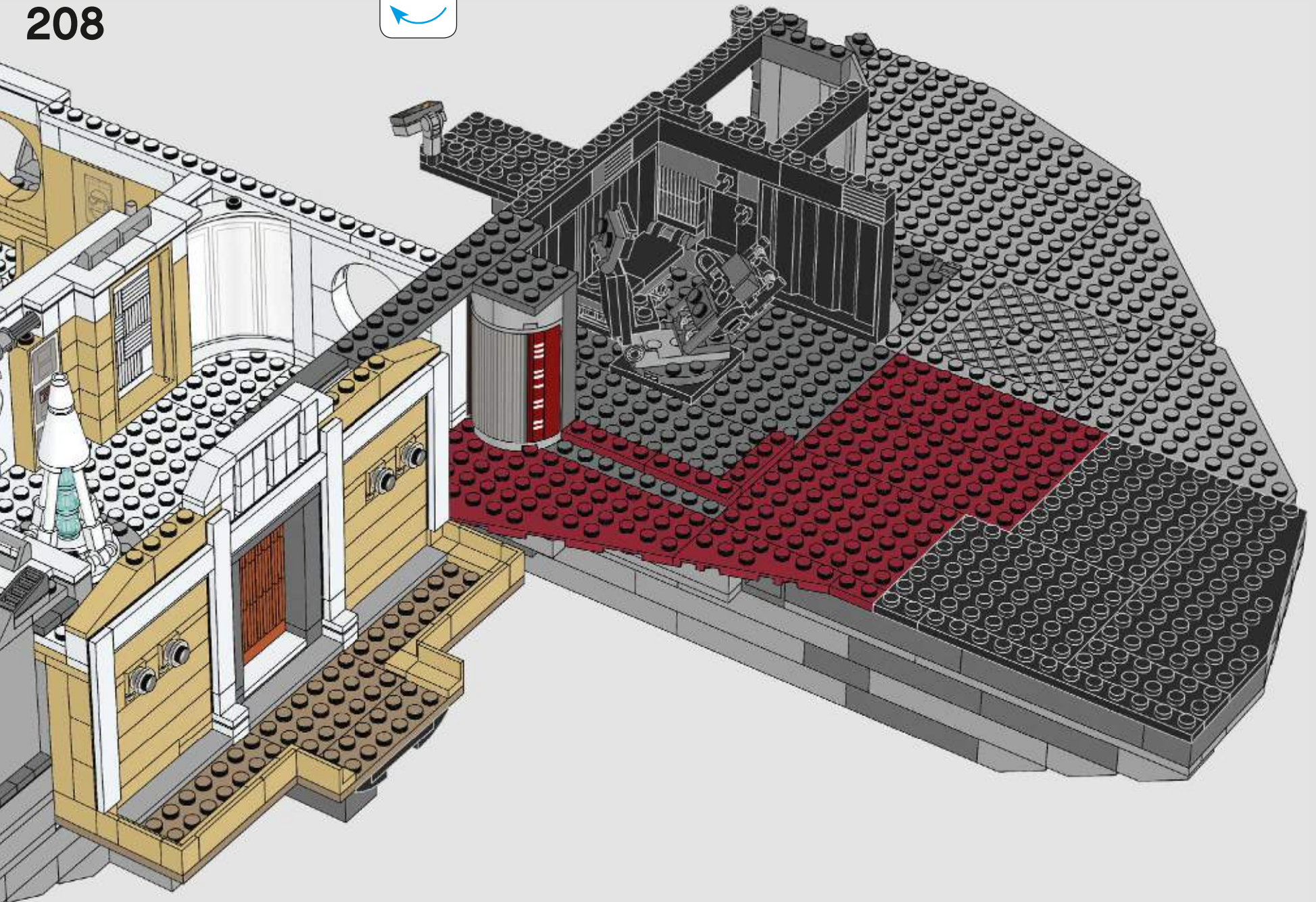

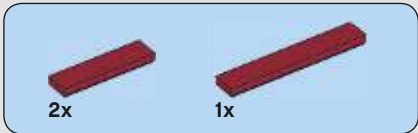

209

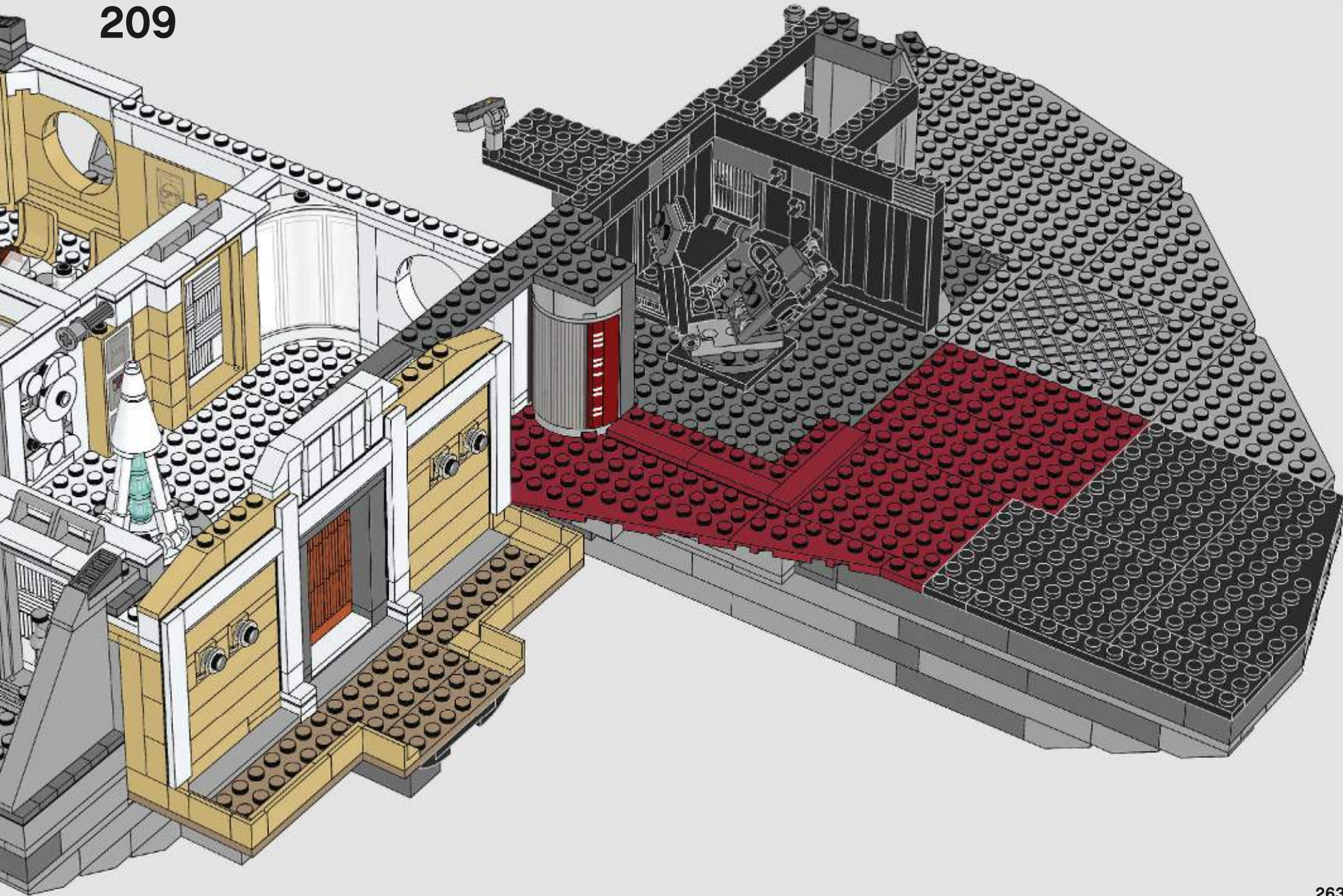



2x



1x



2x

210

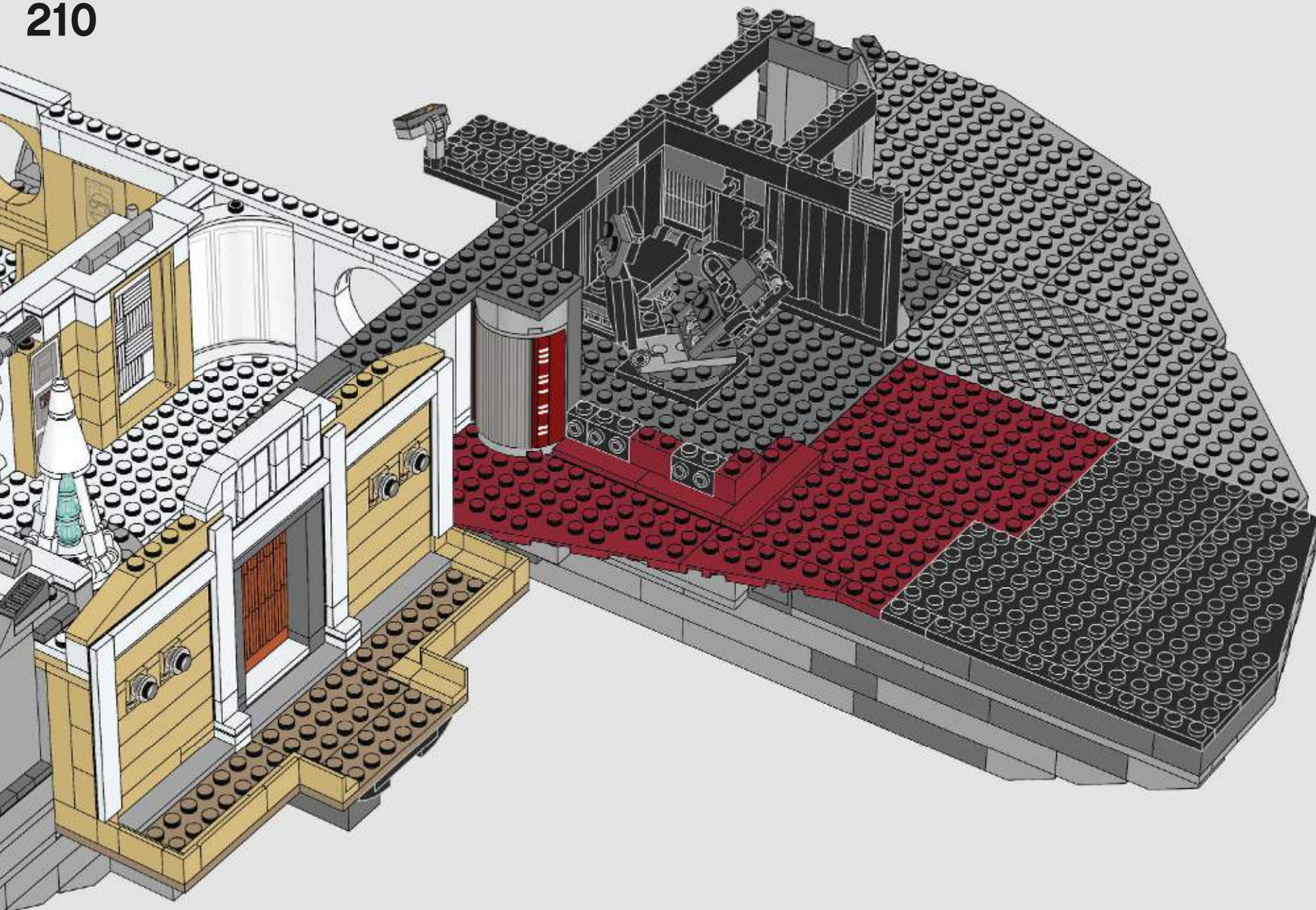

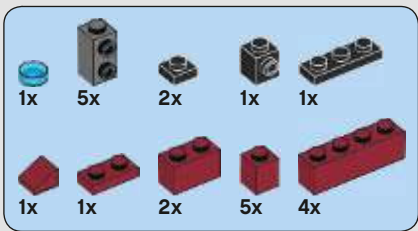

211

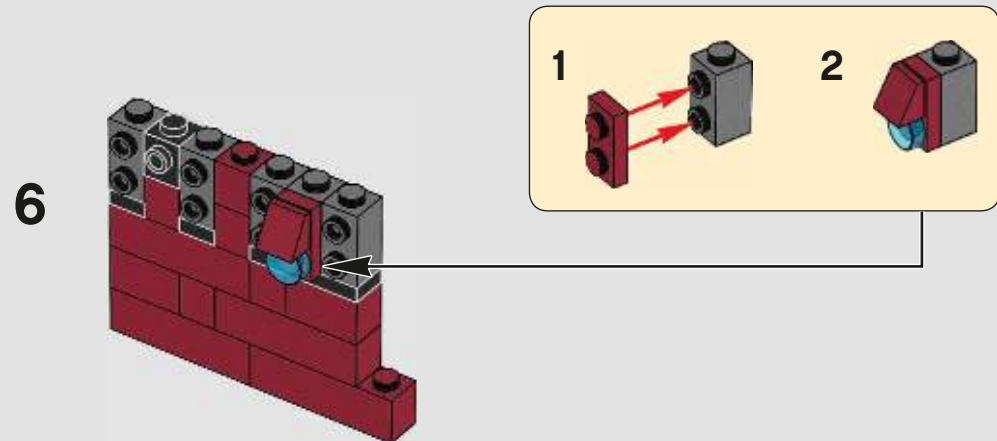
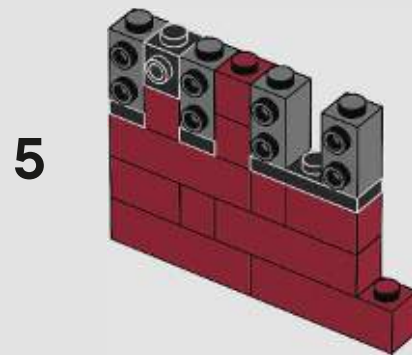
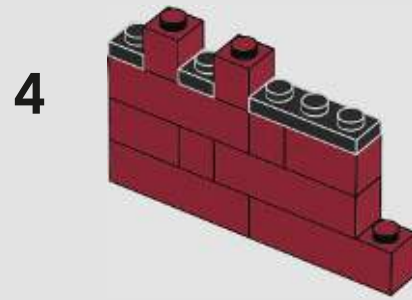
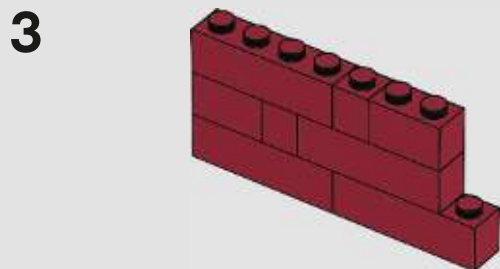
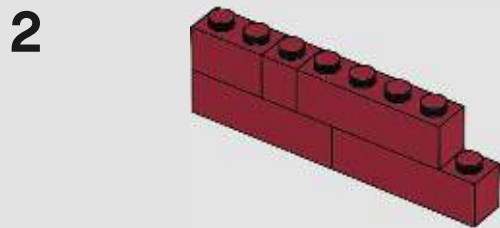
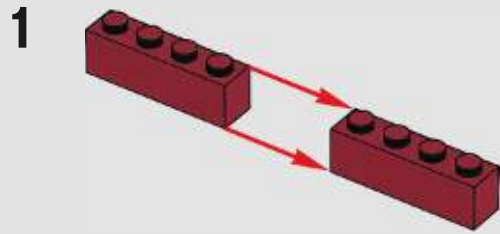

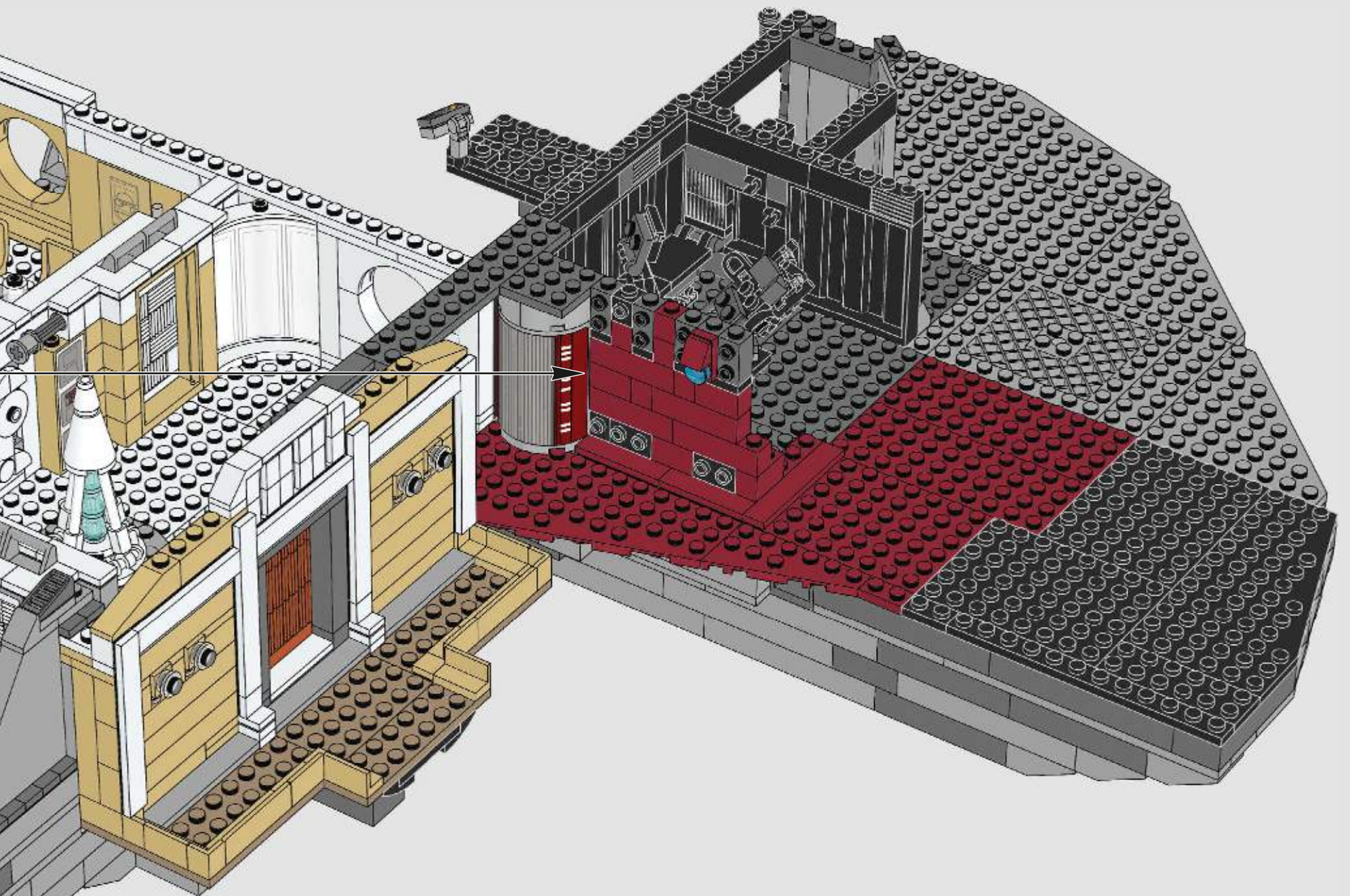

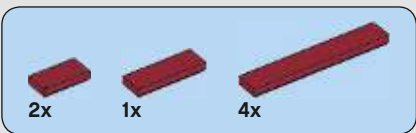

212

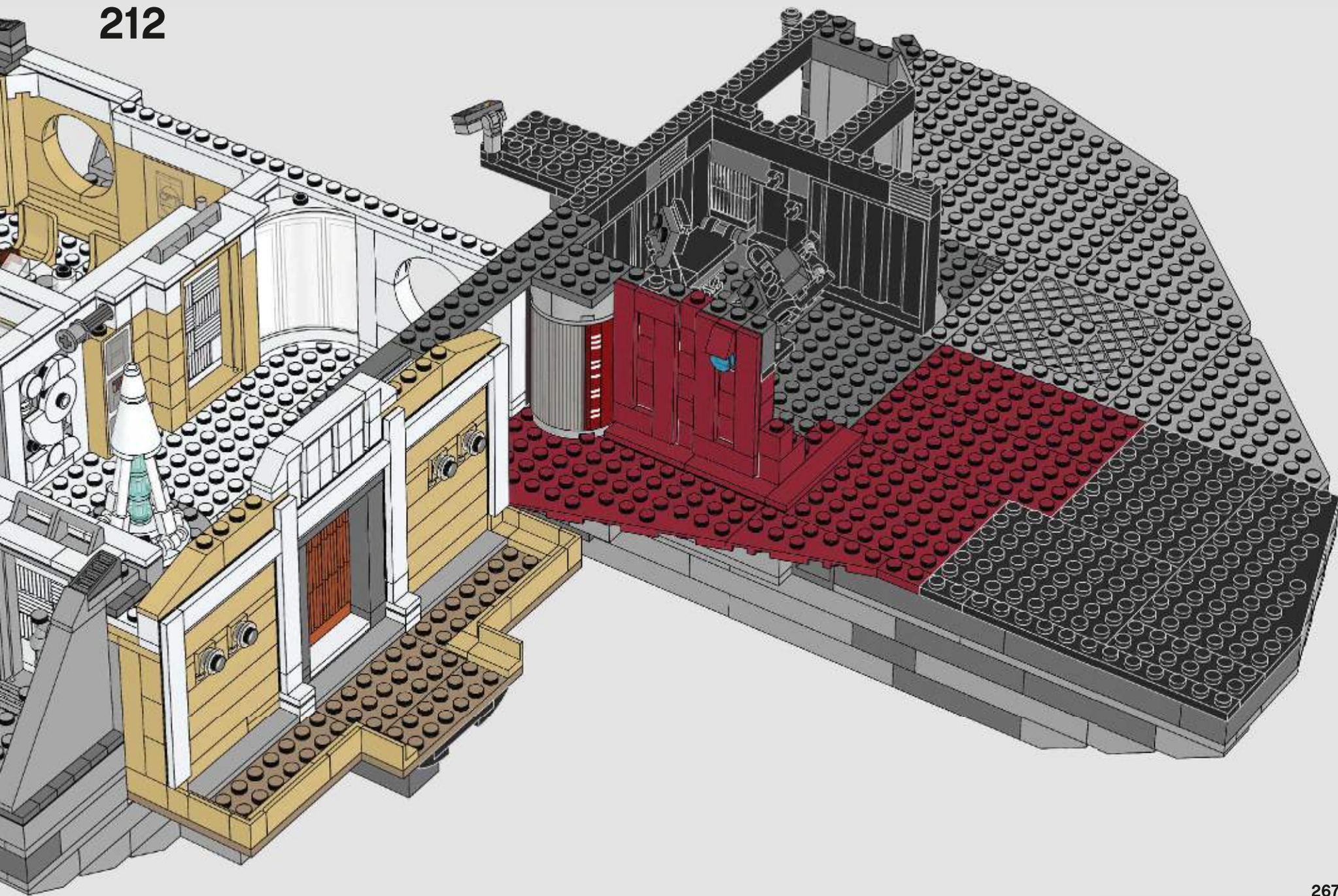

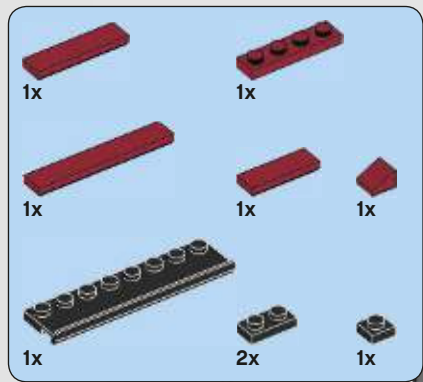

213

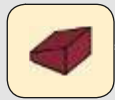

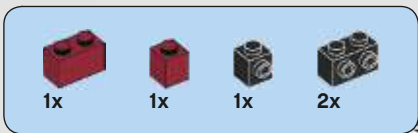

214

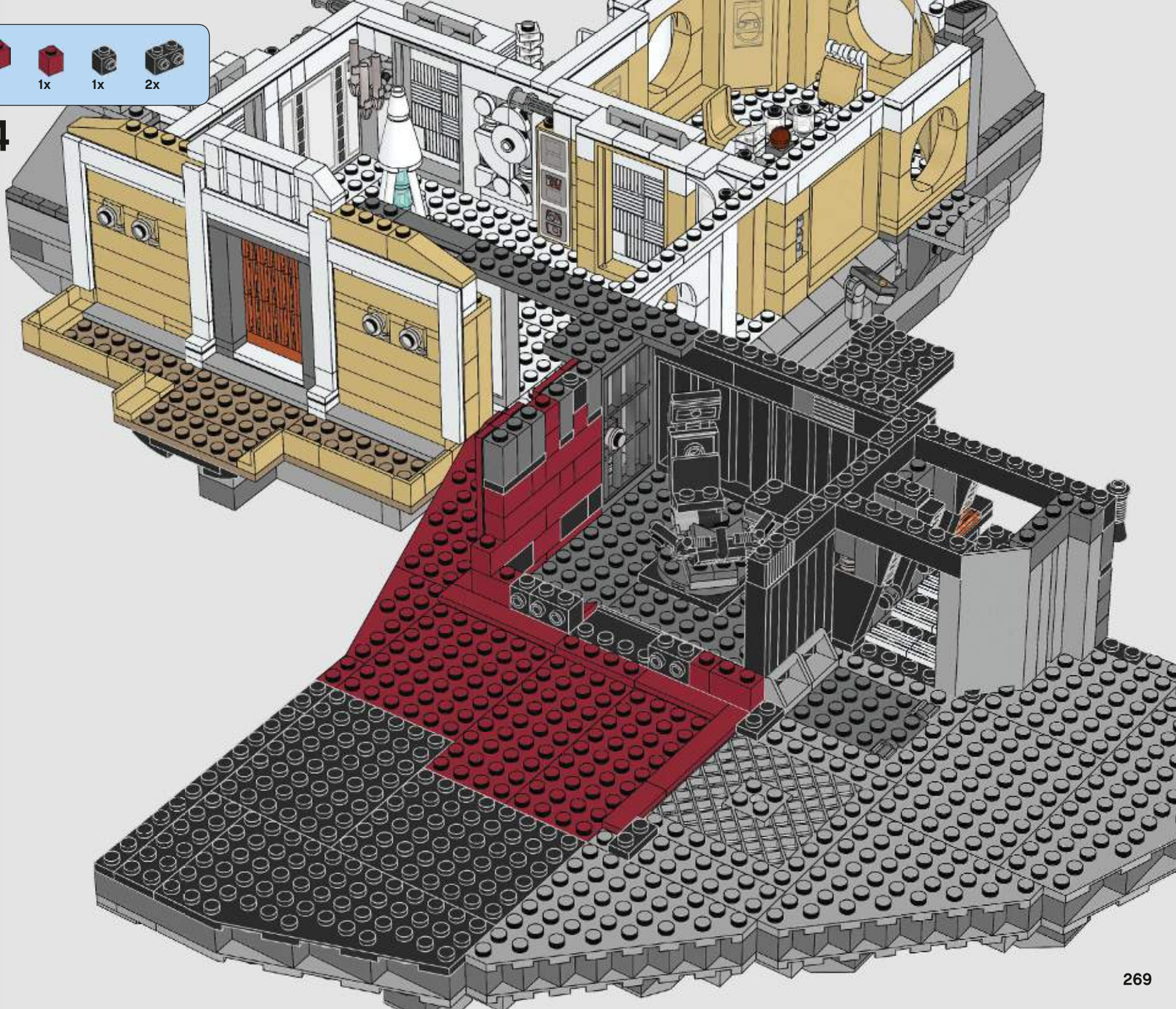

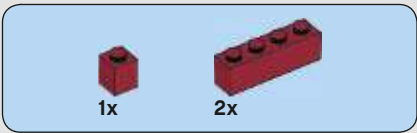

215

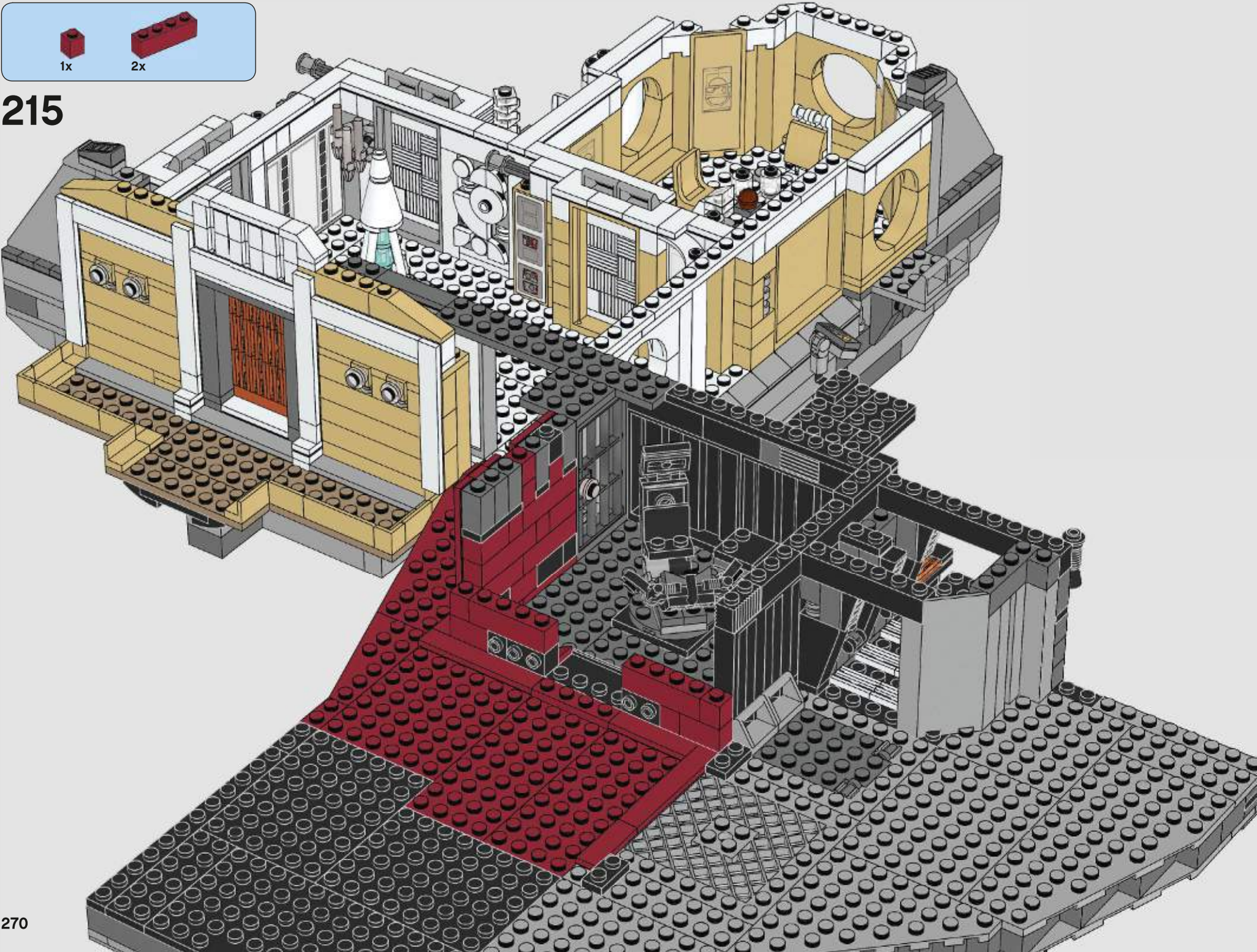

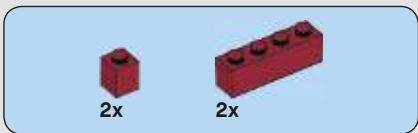

216

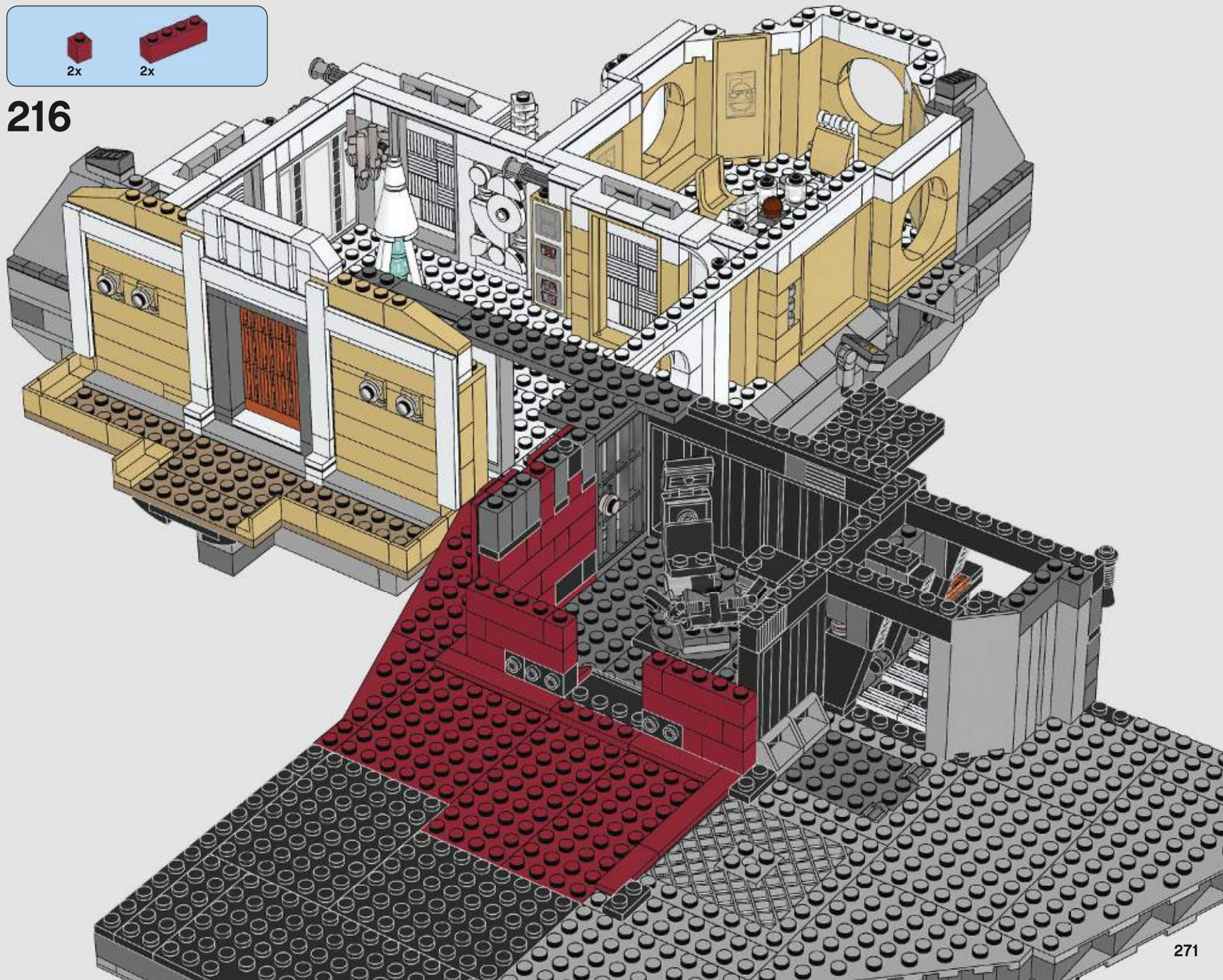

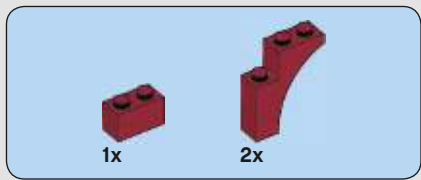

217

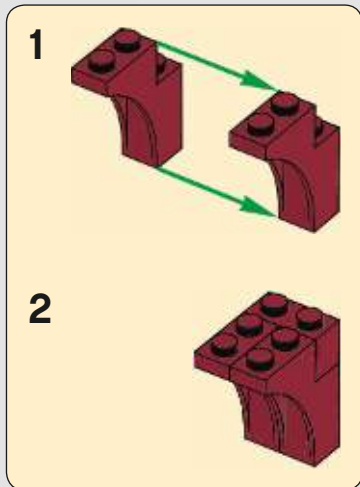
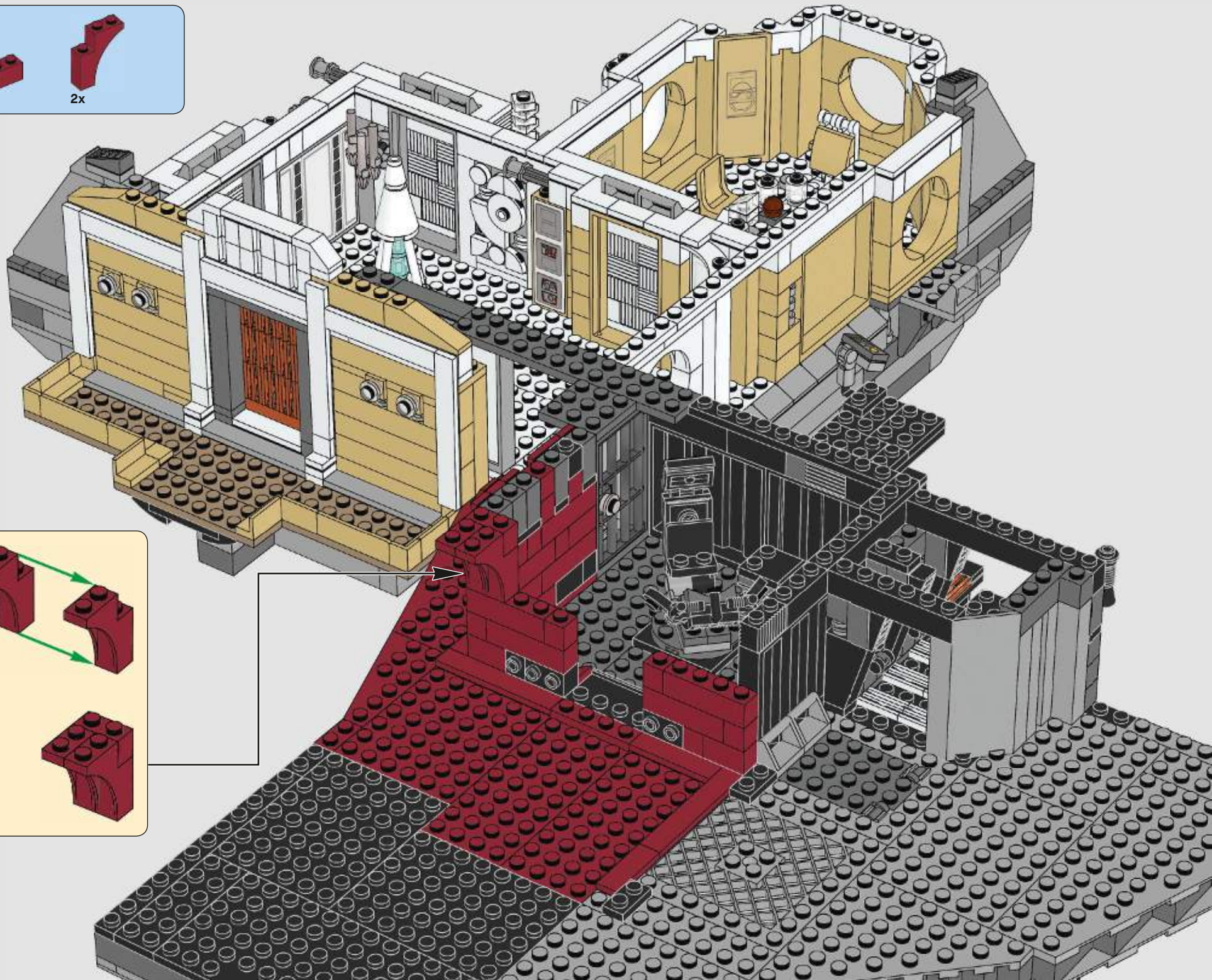

272

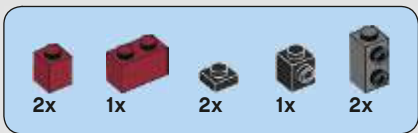

218

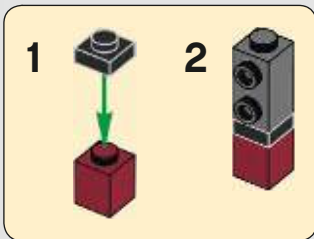
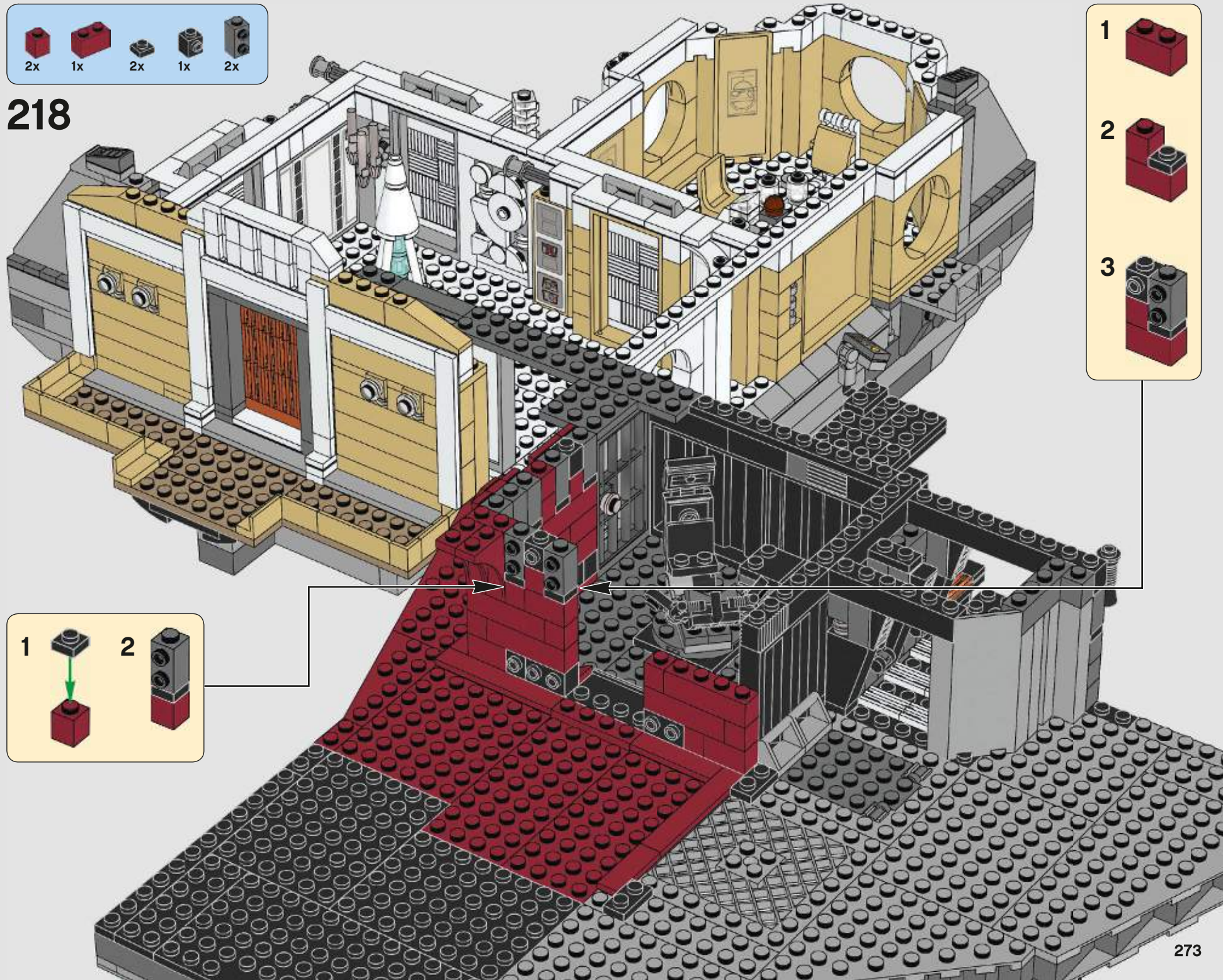

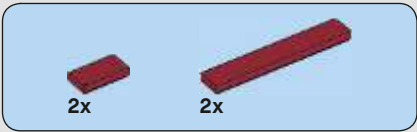

219

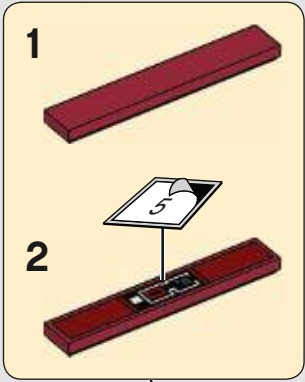
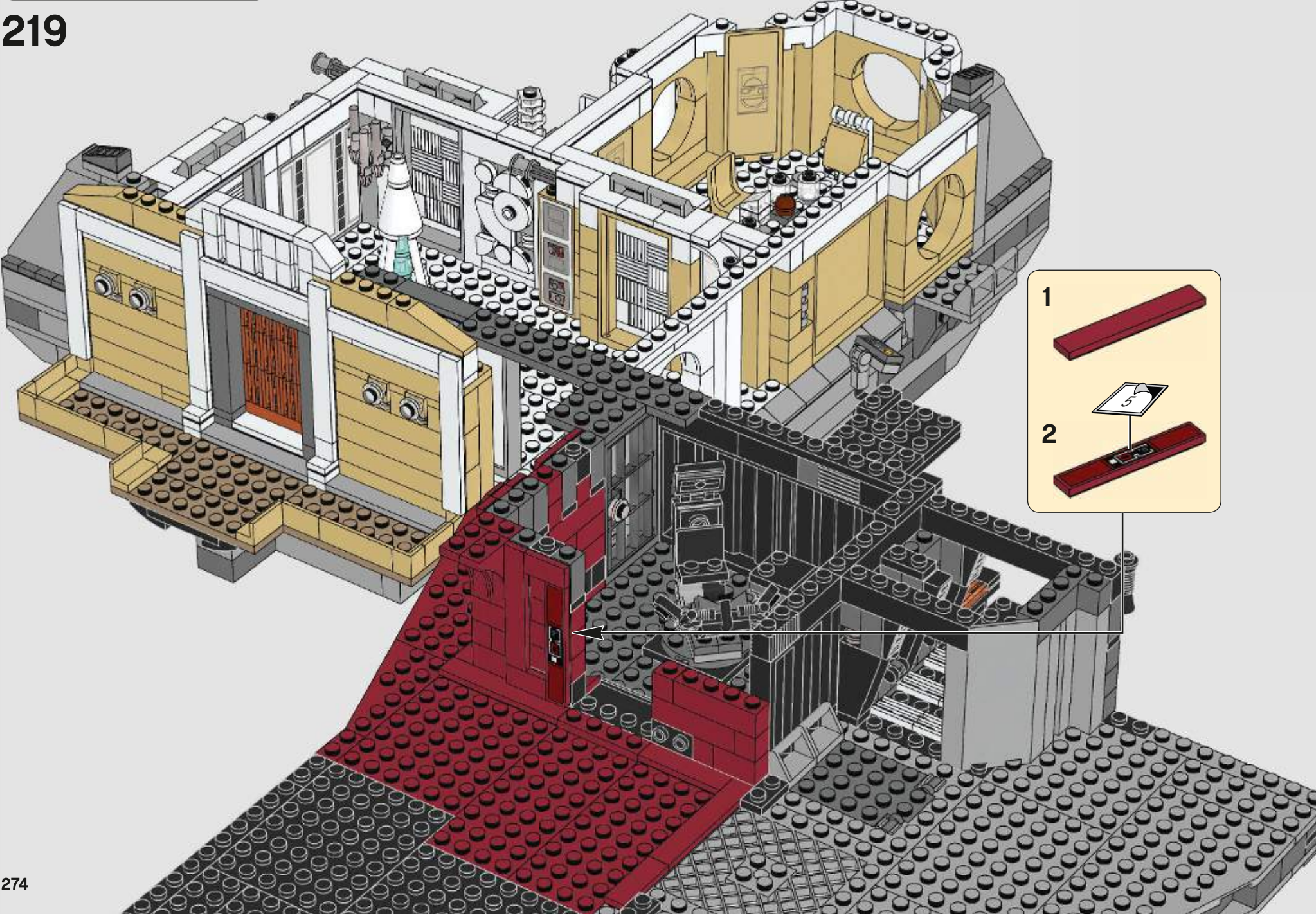

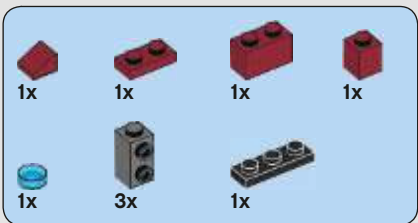

220

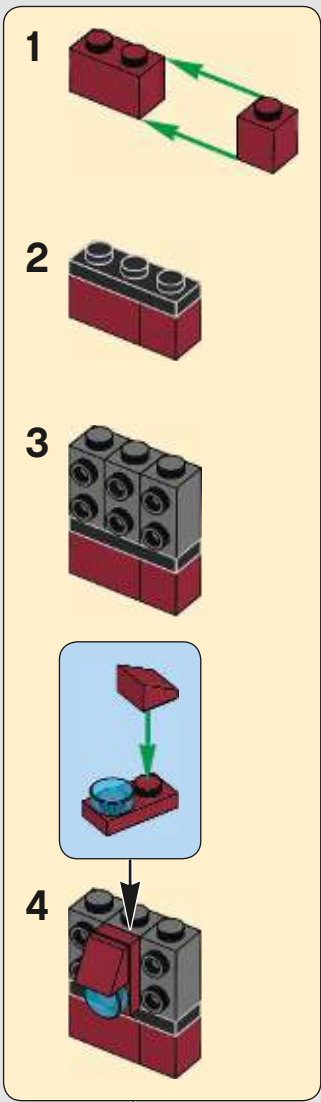
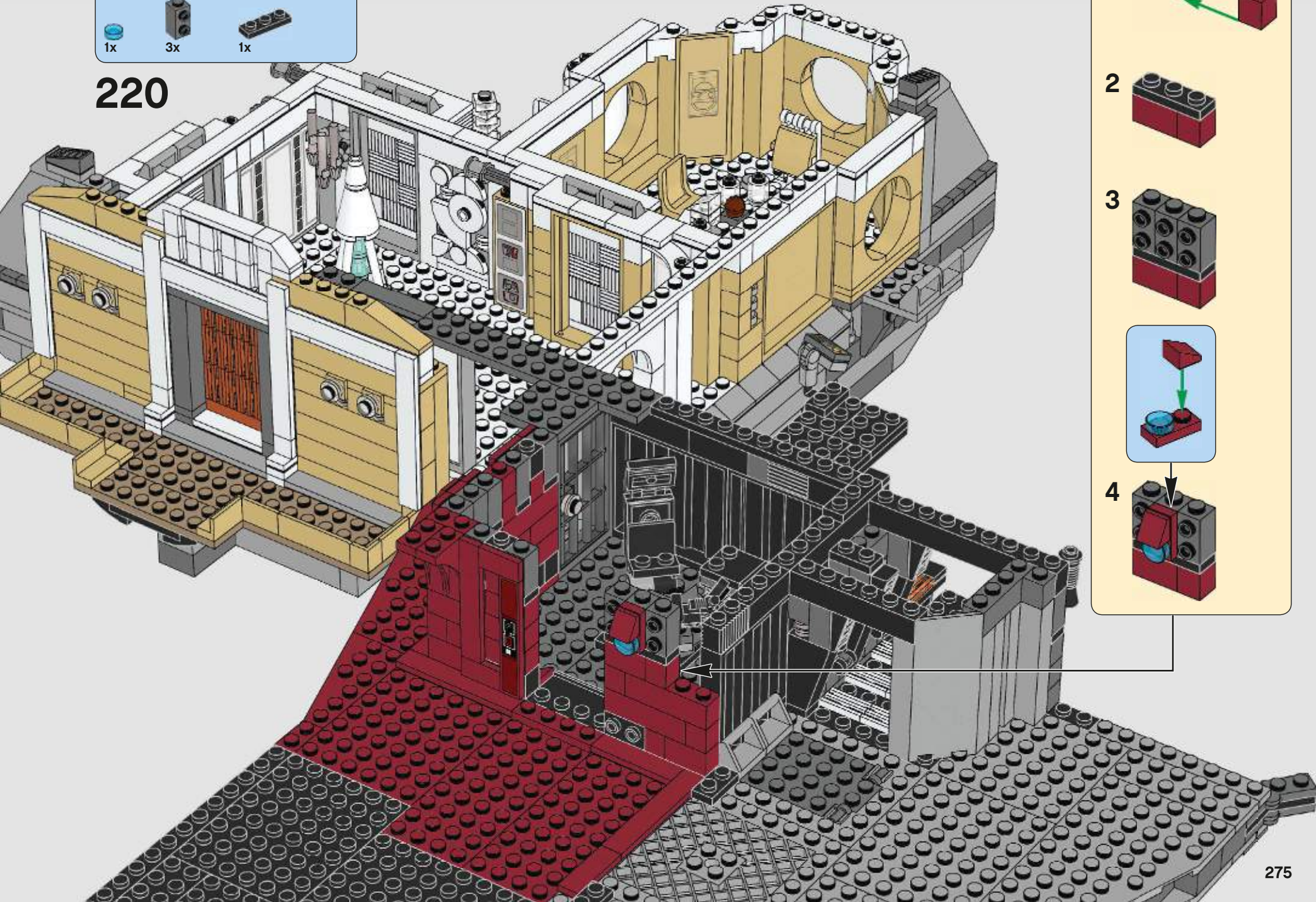

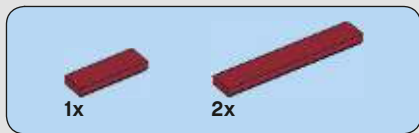

221



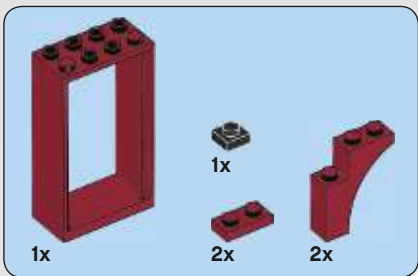

222

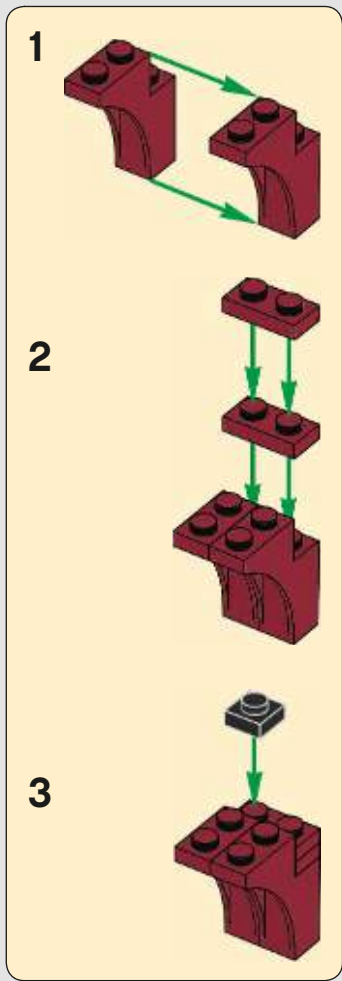
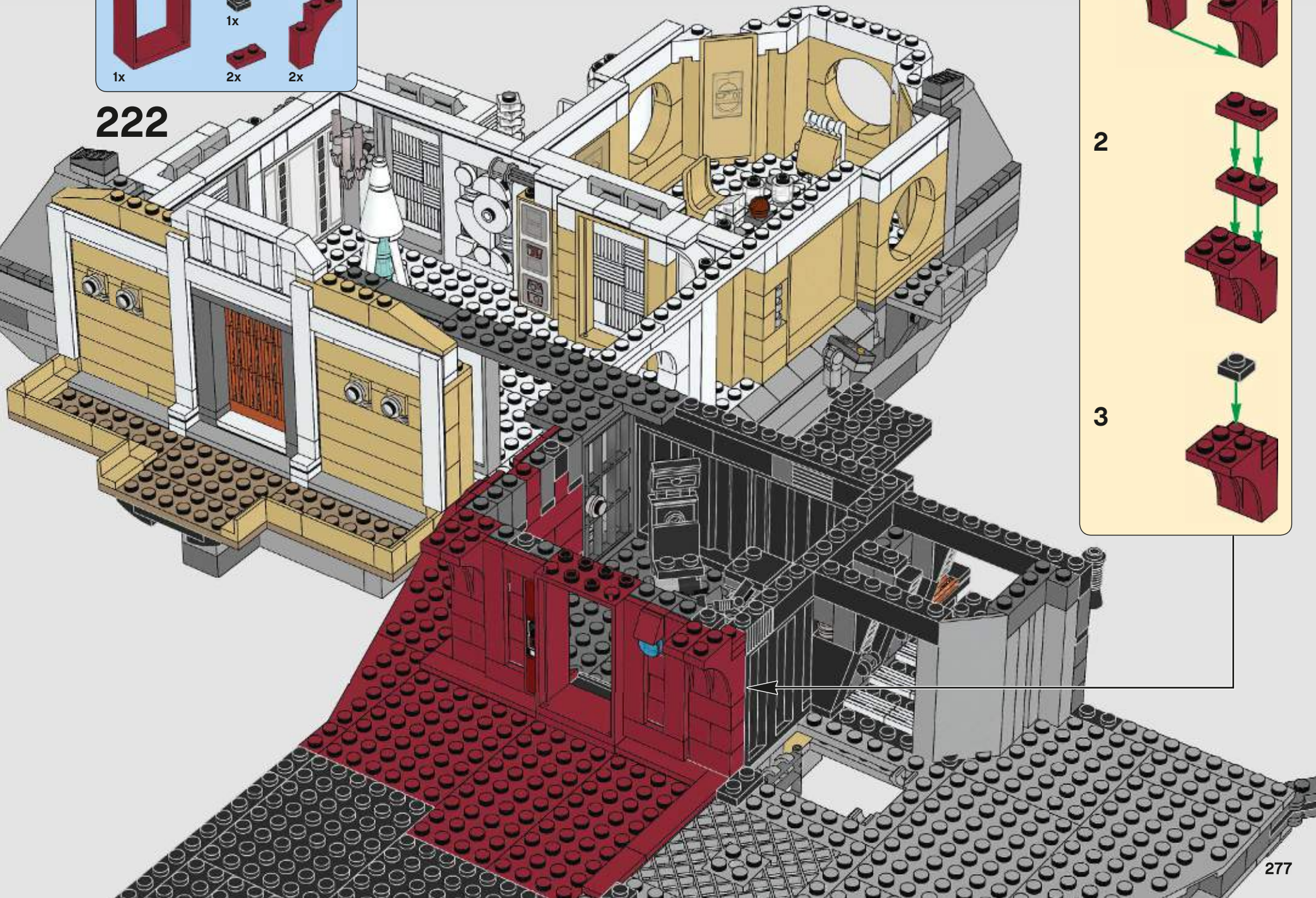

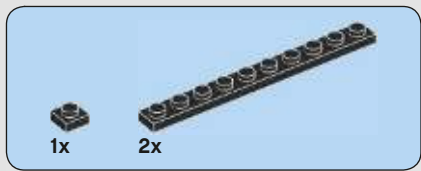

223

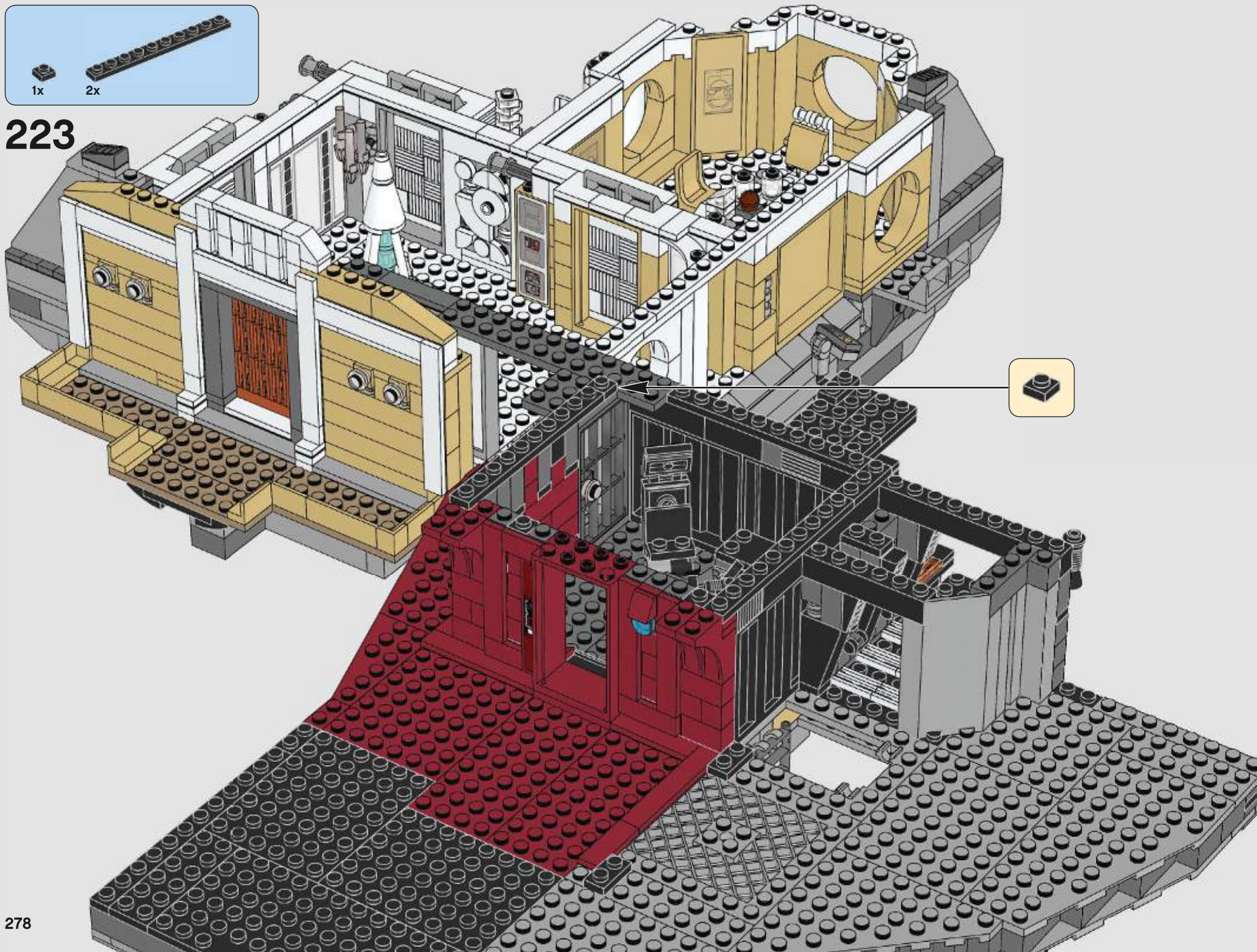

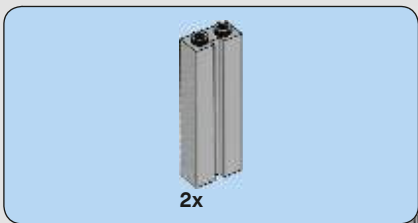

224

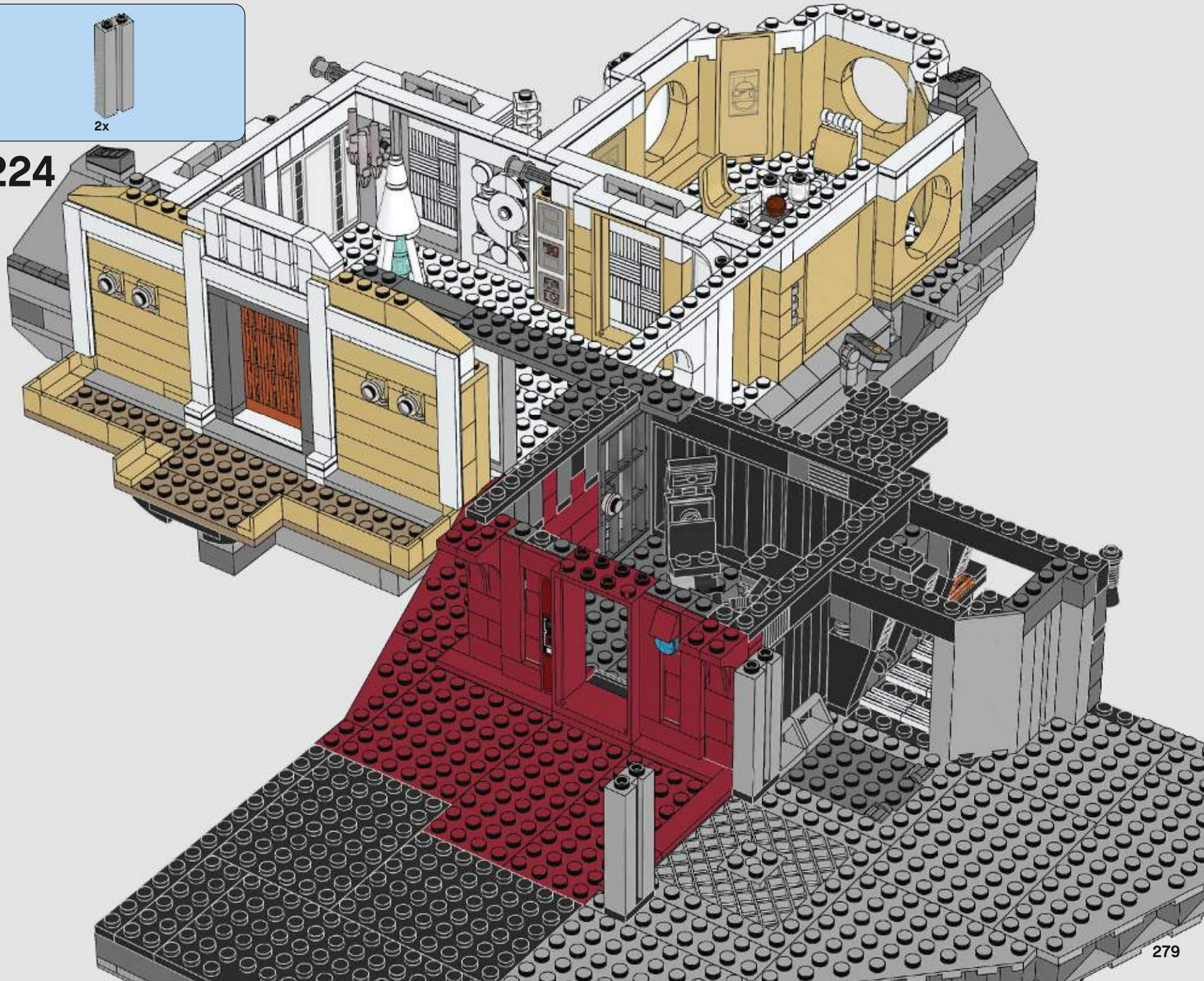

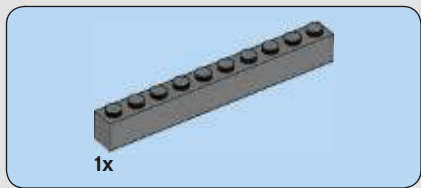

225

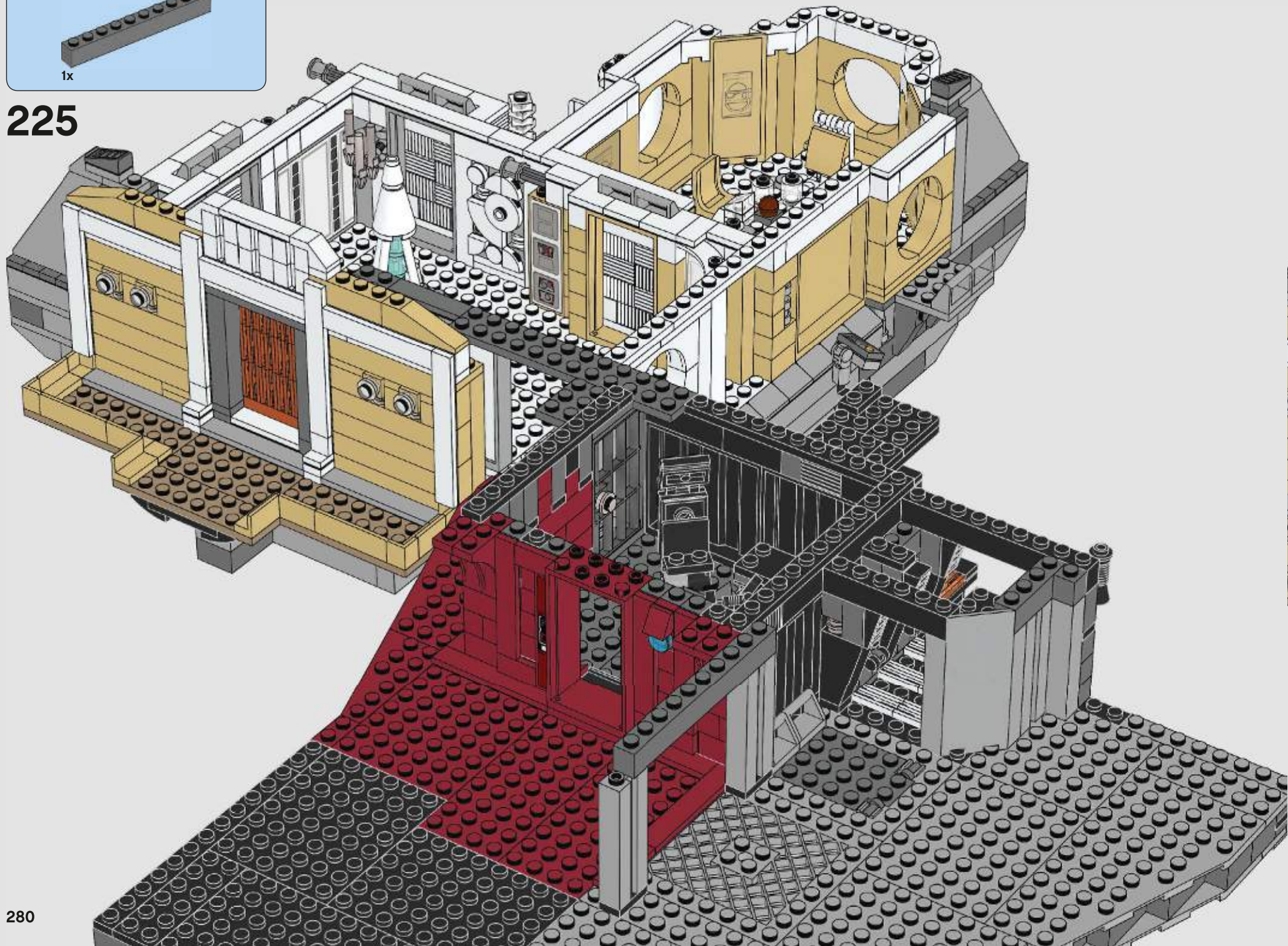

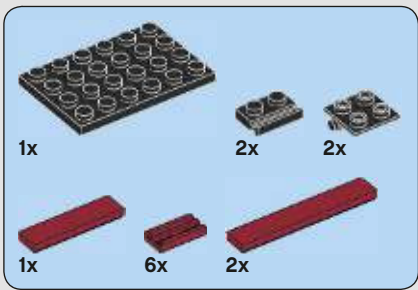

226

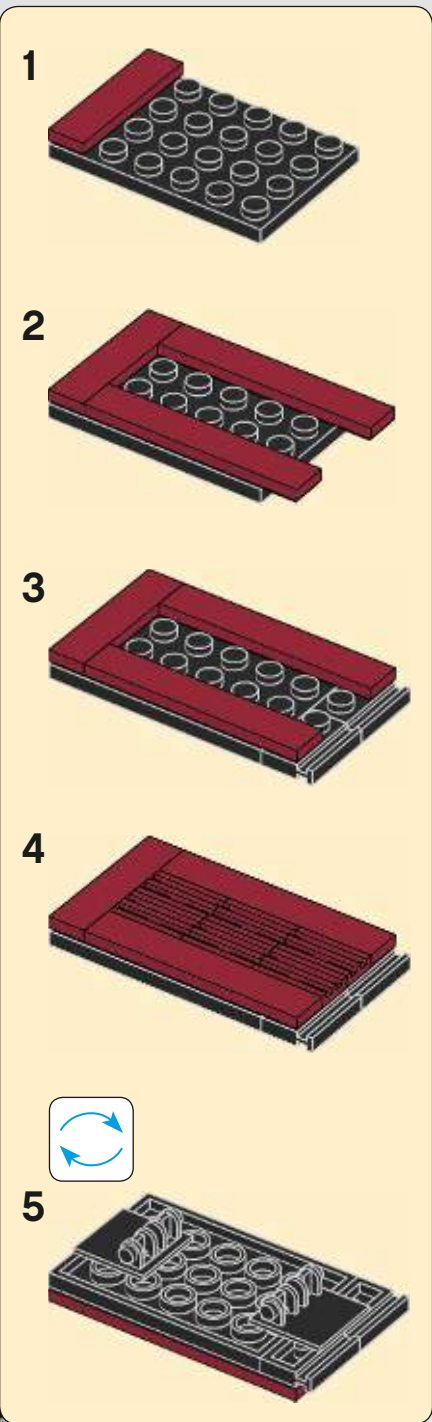
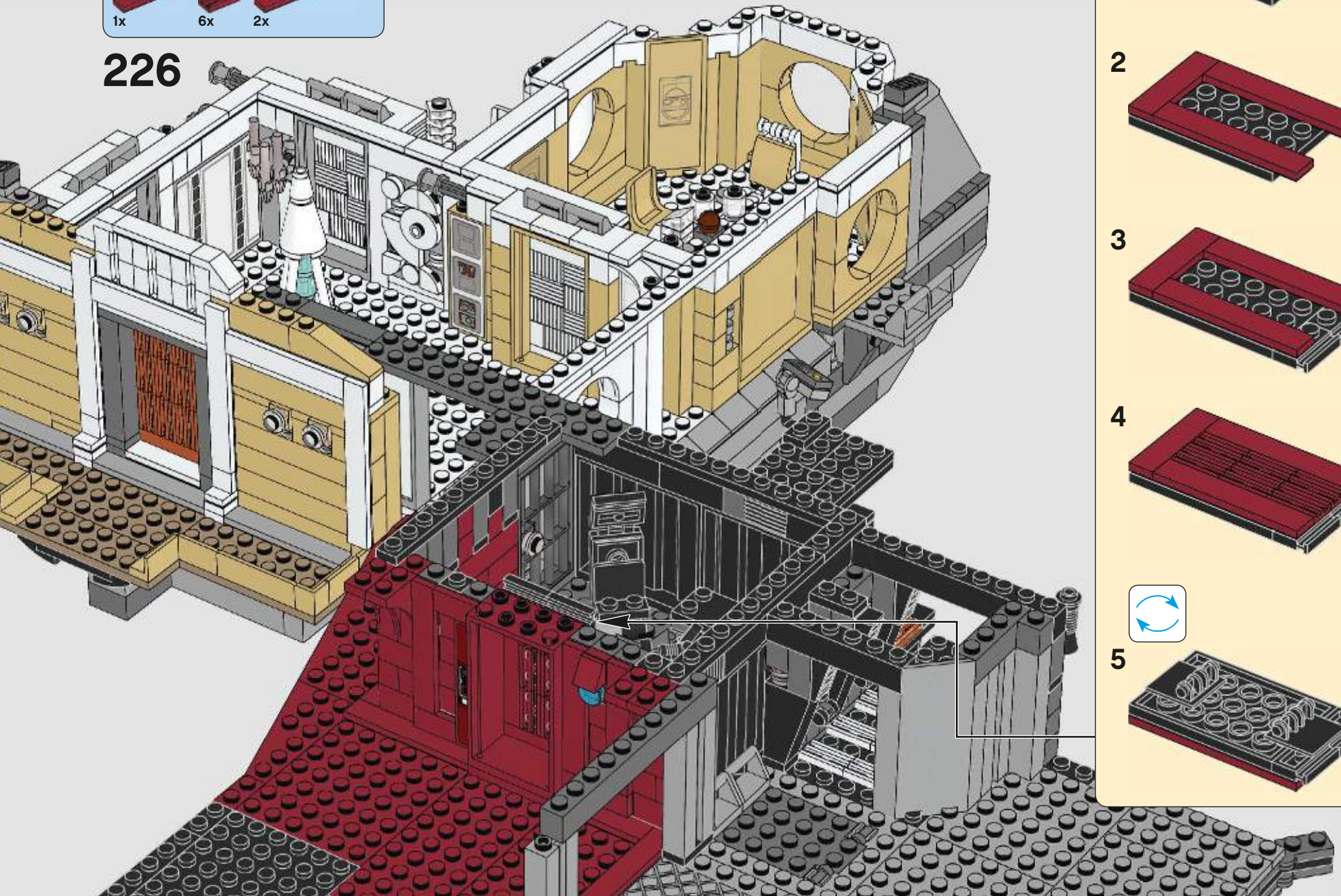

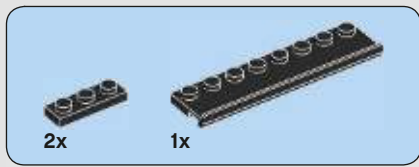

227

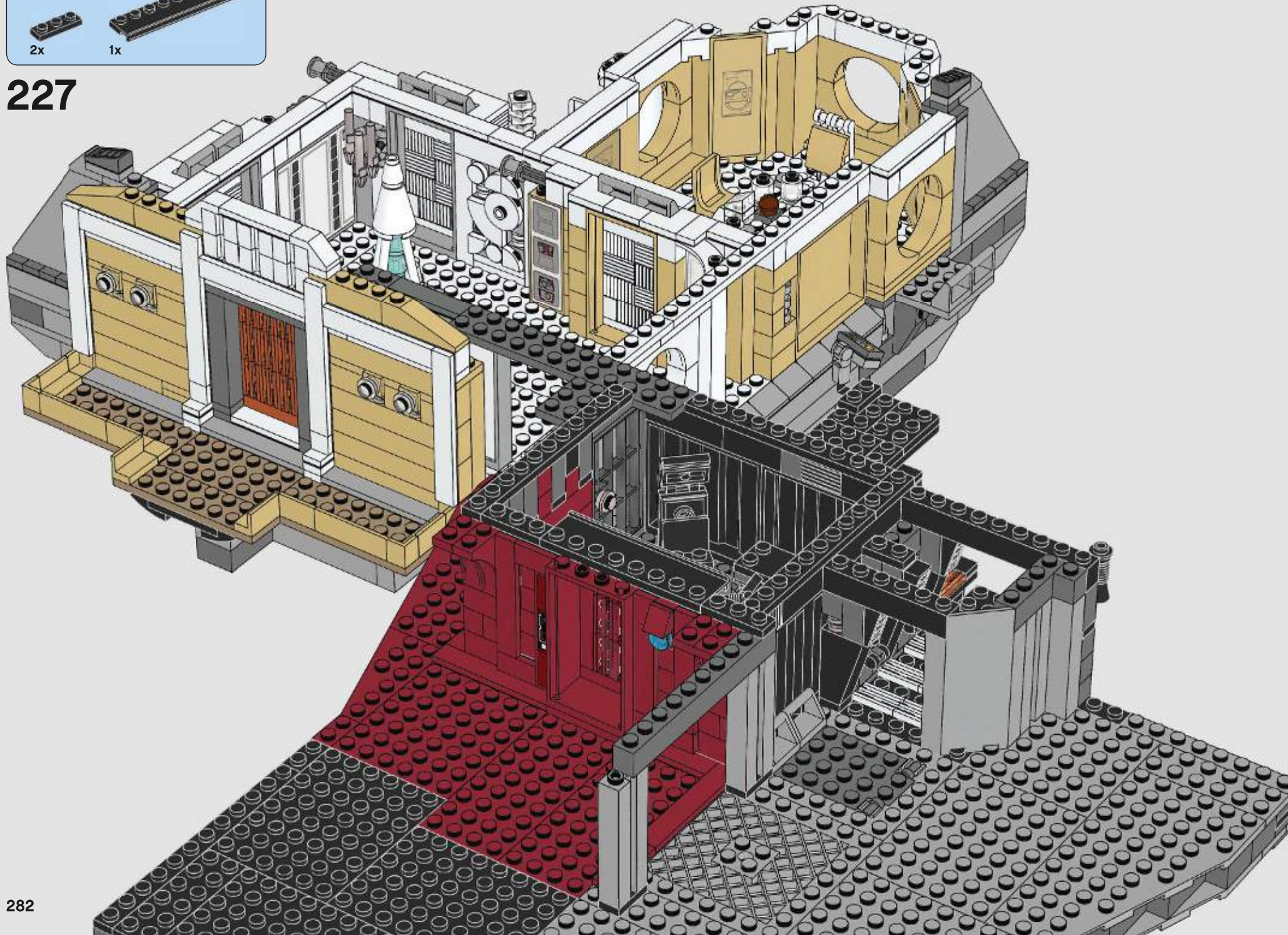



228

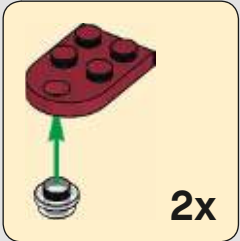

2x  2x 

229

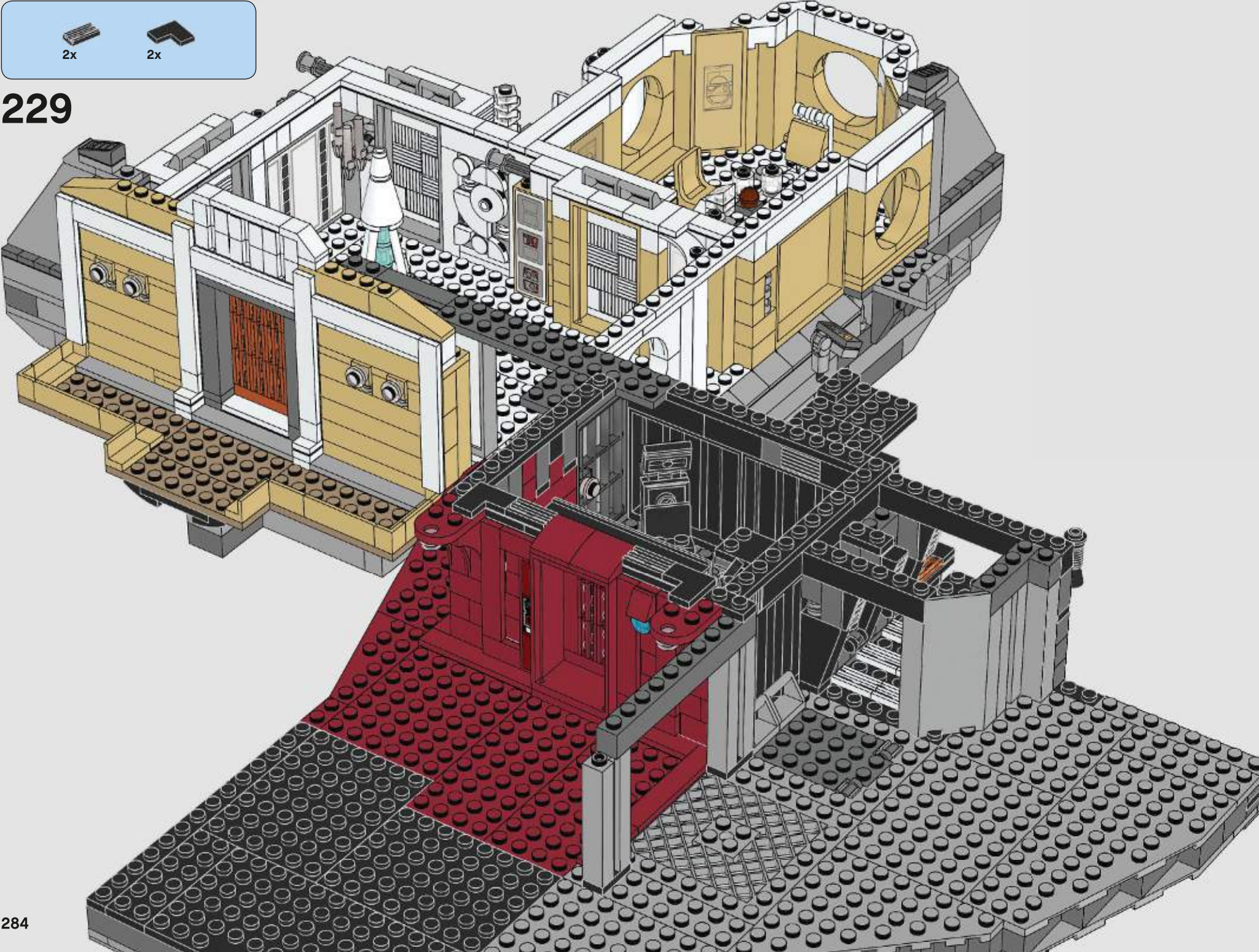

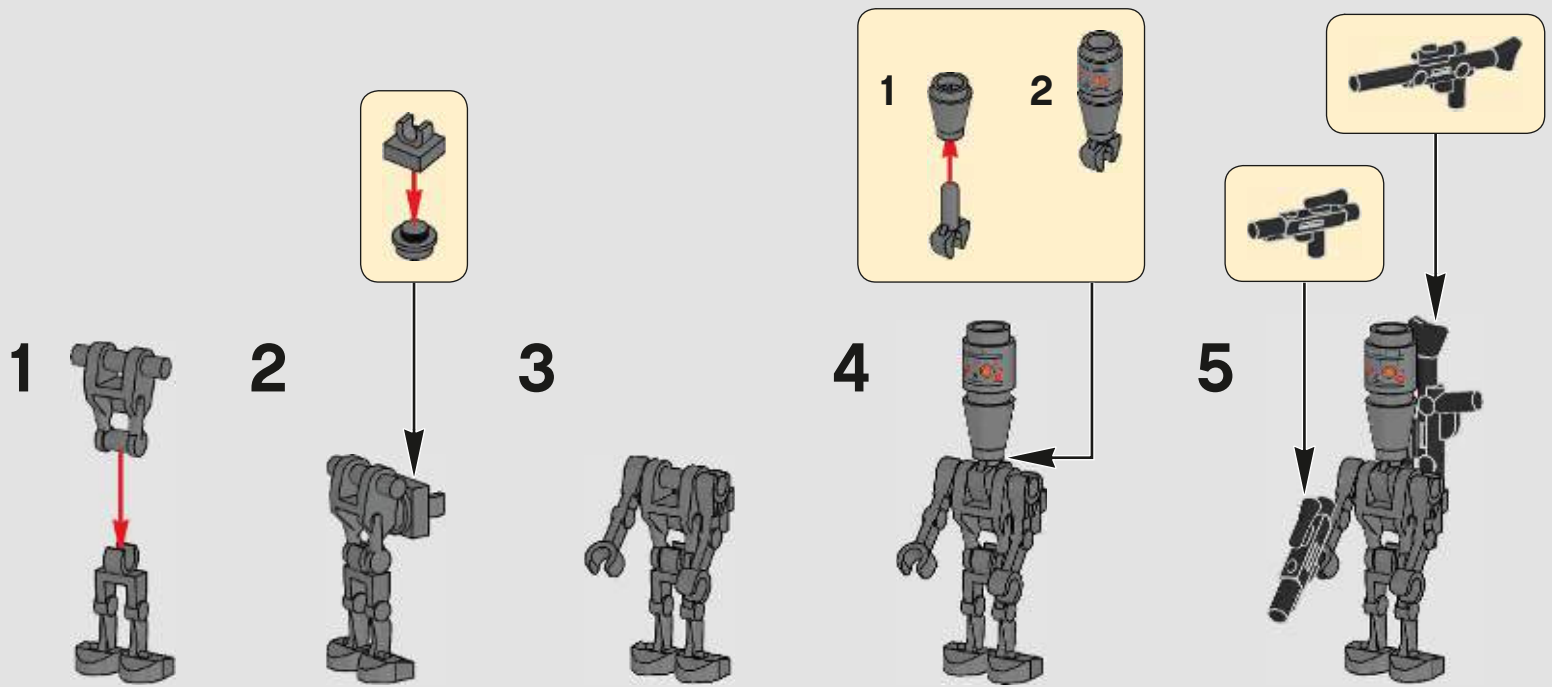
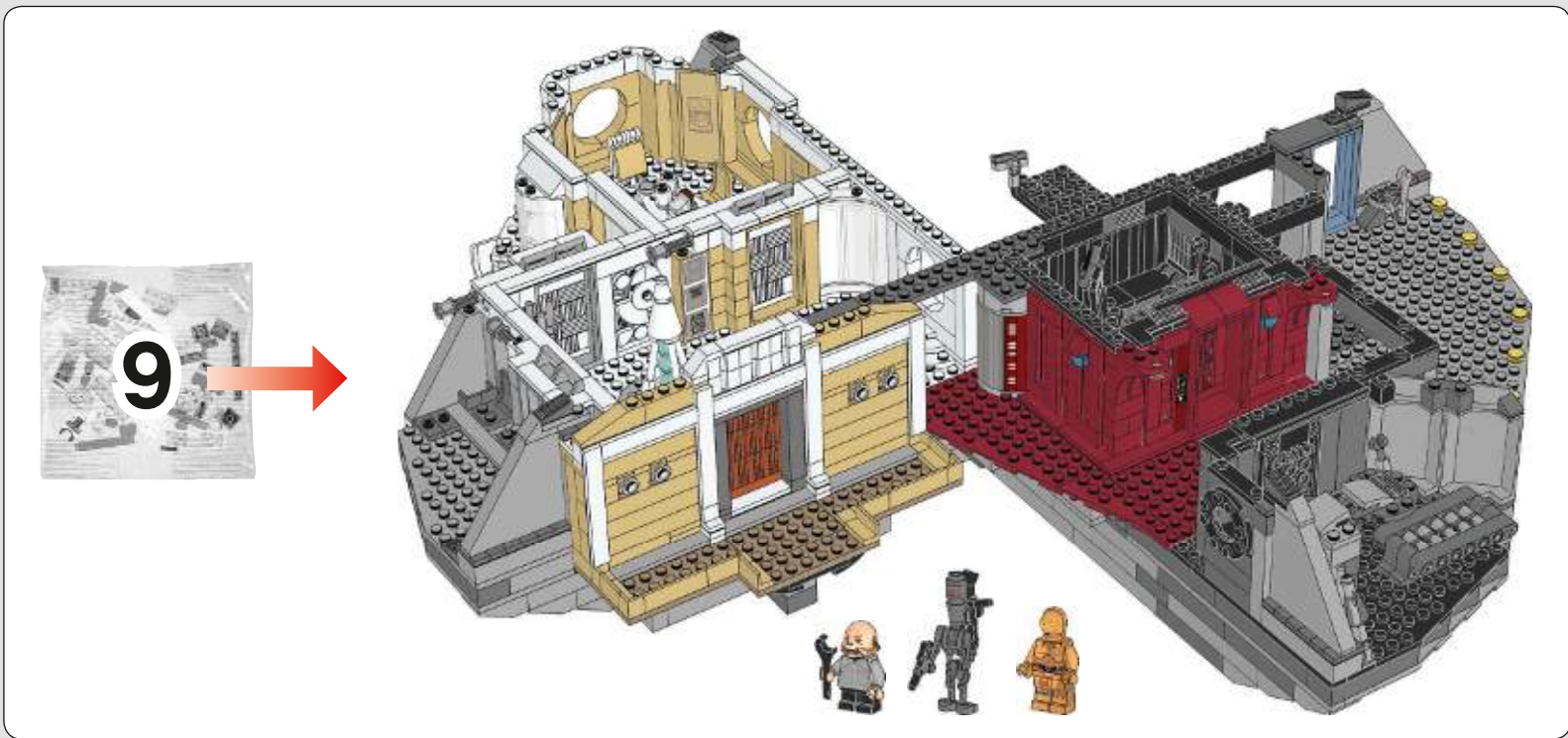

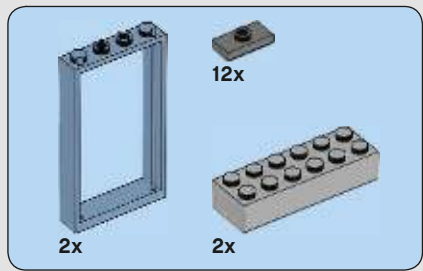

230

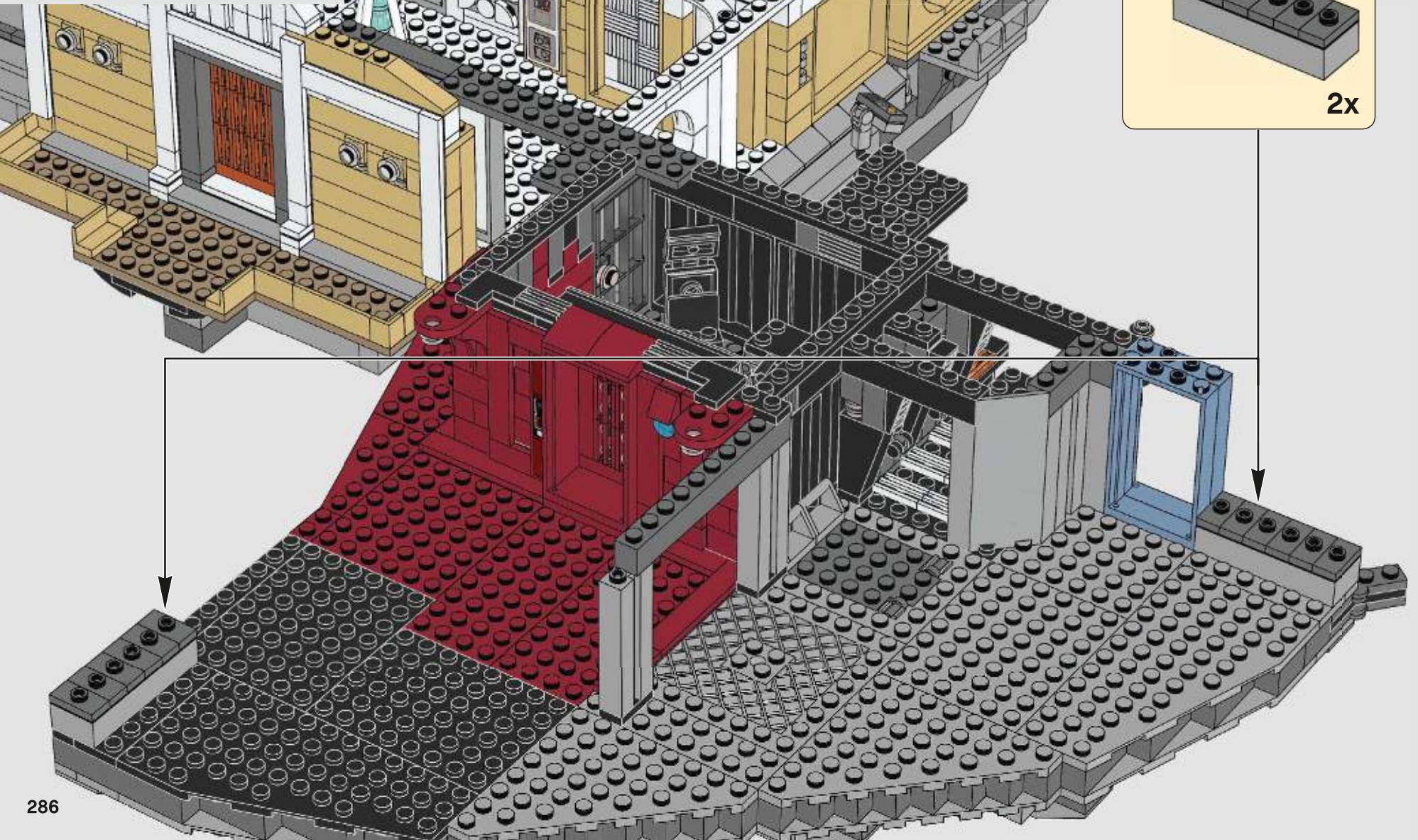
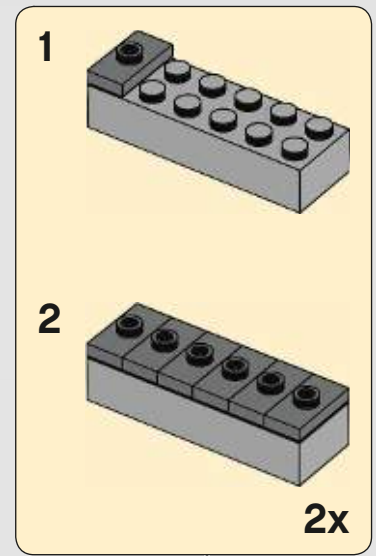

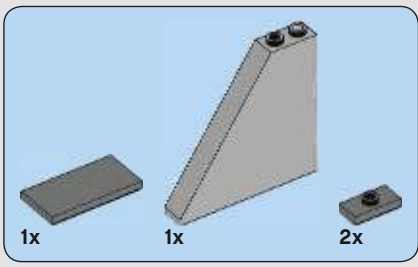

231

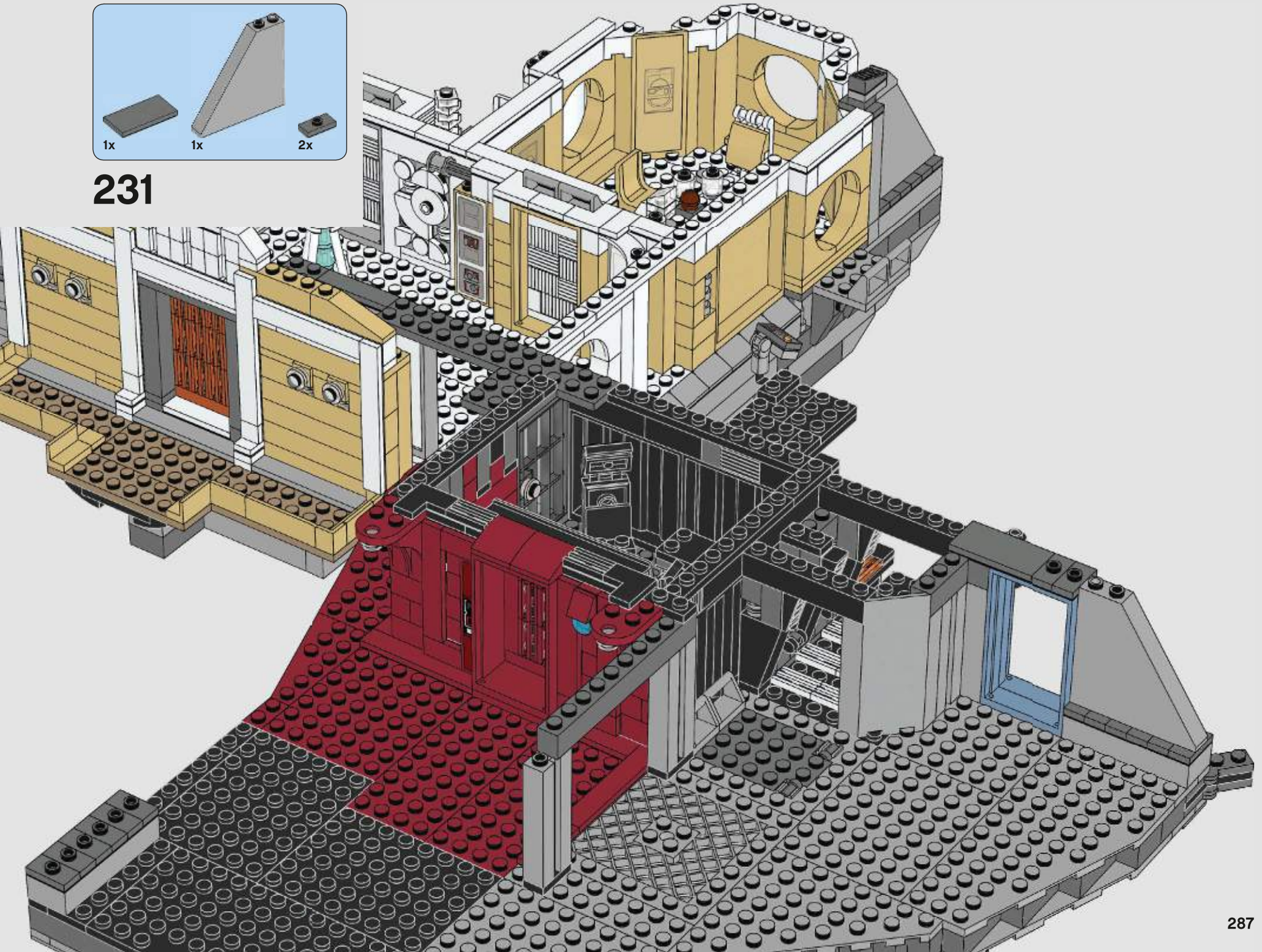



232

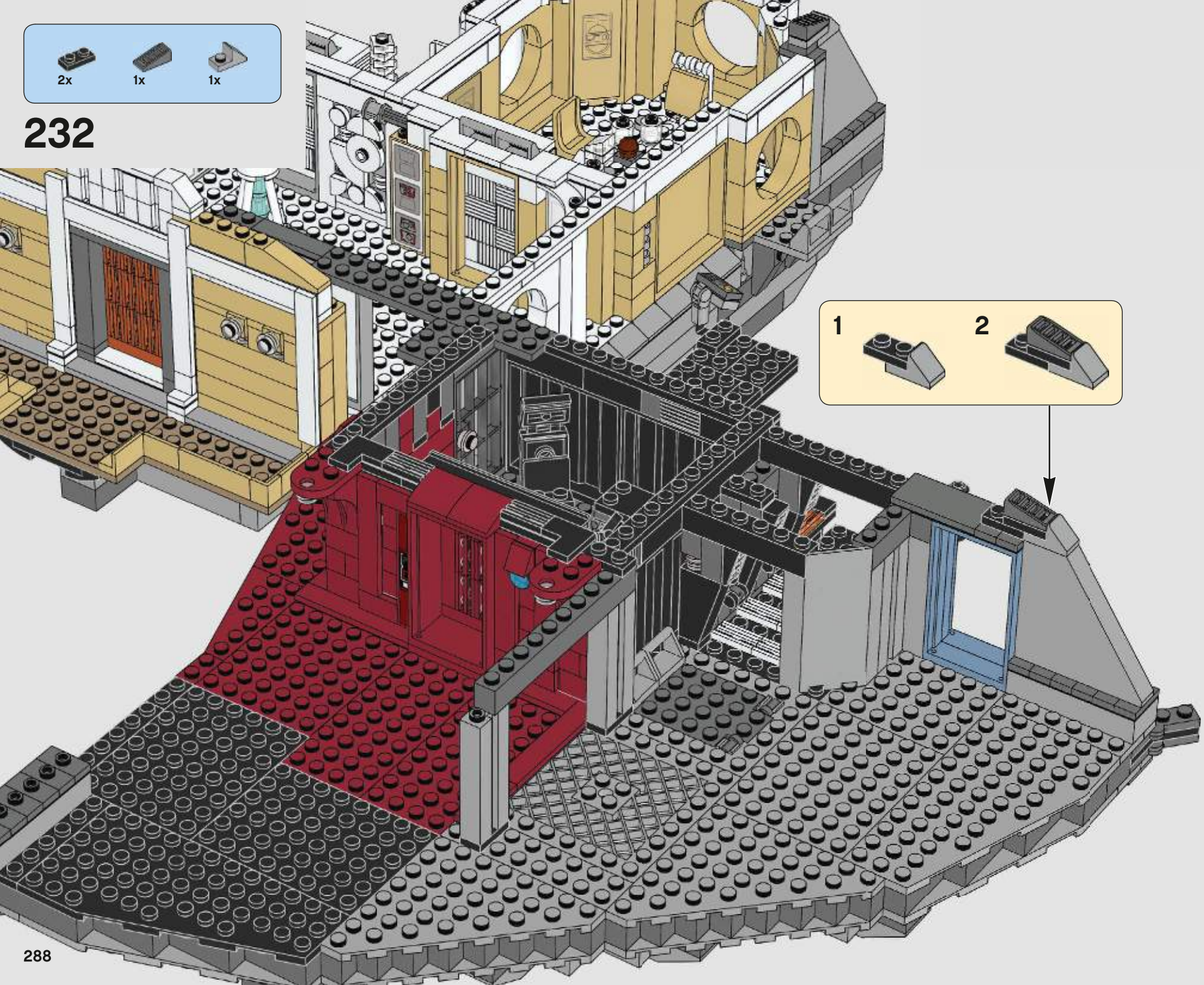



233

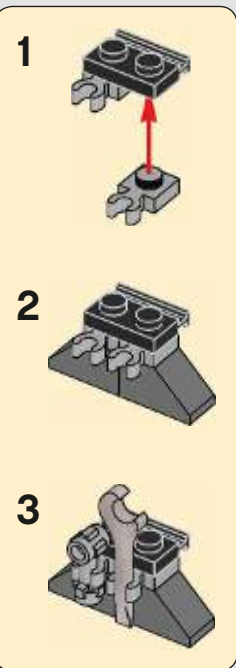
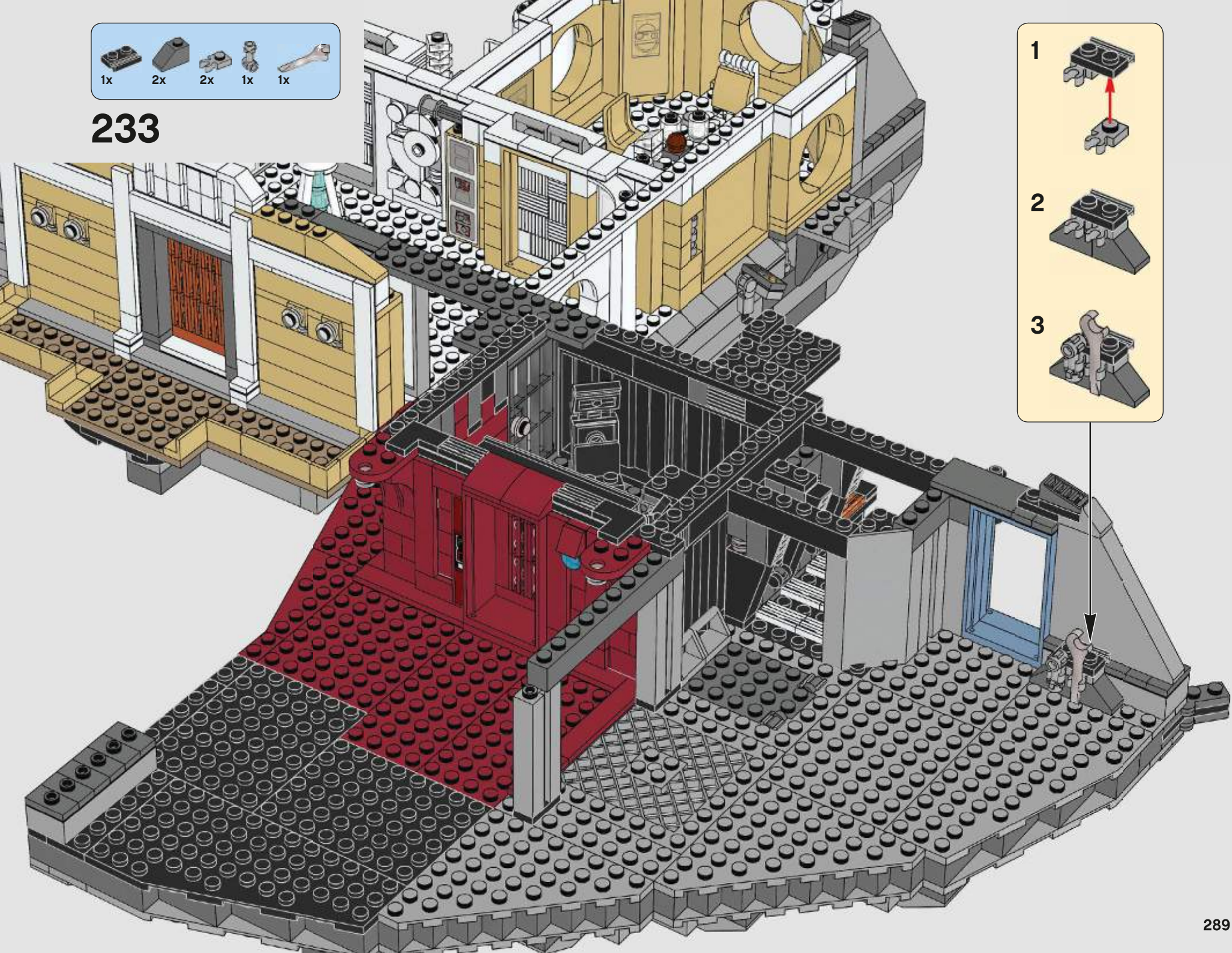

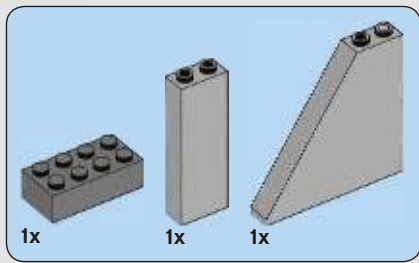

234

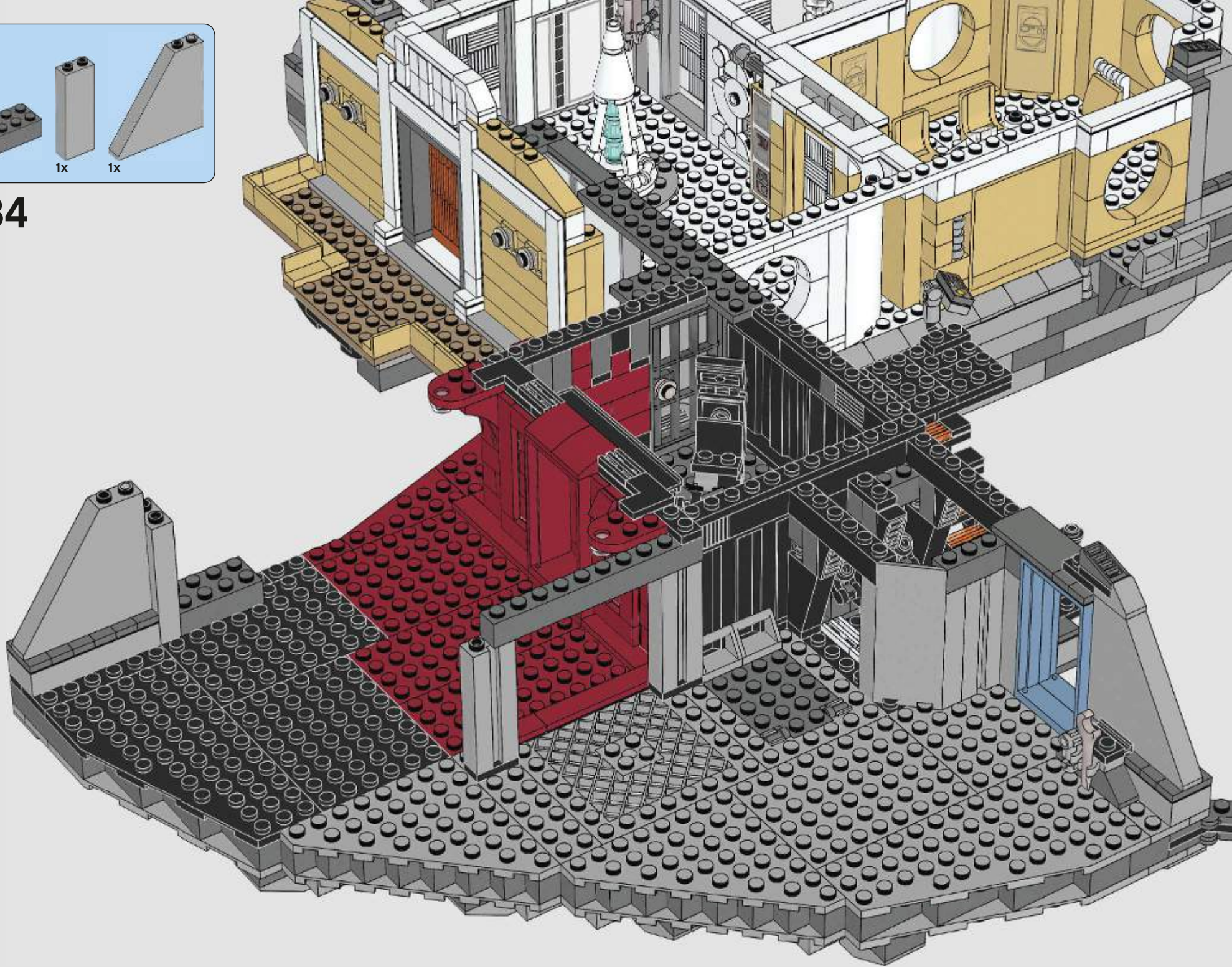

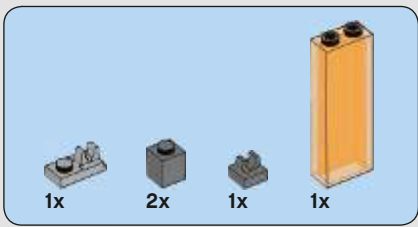

235

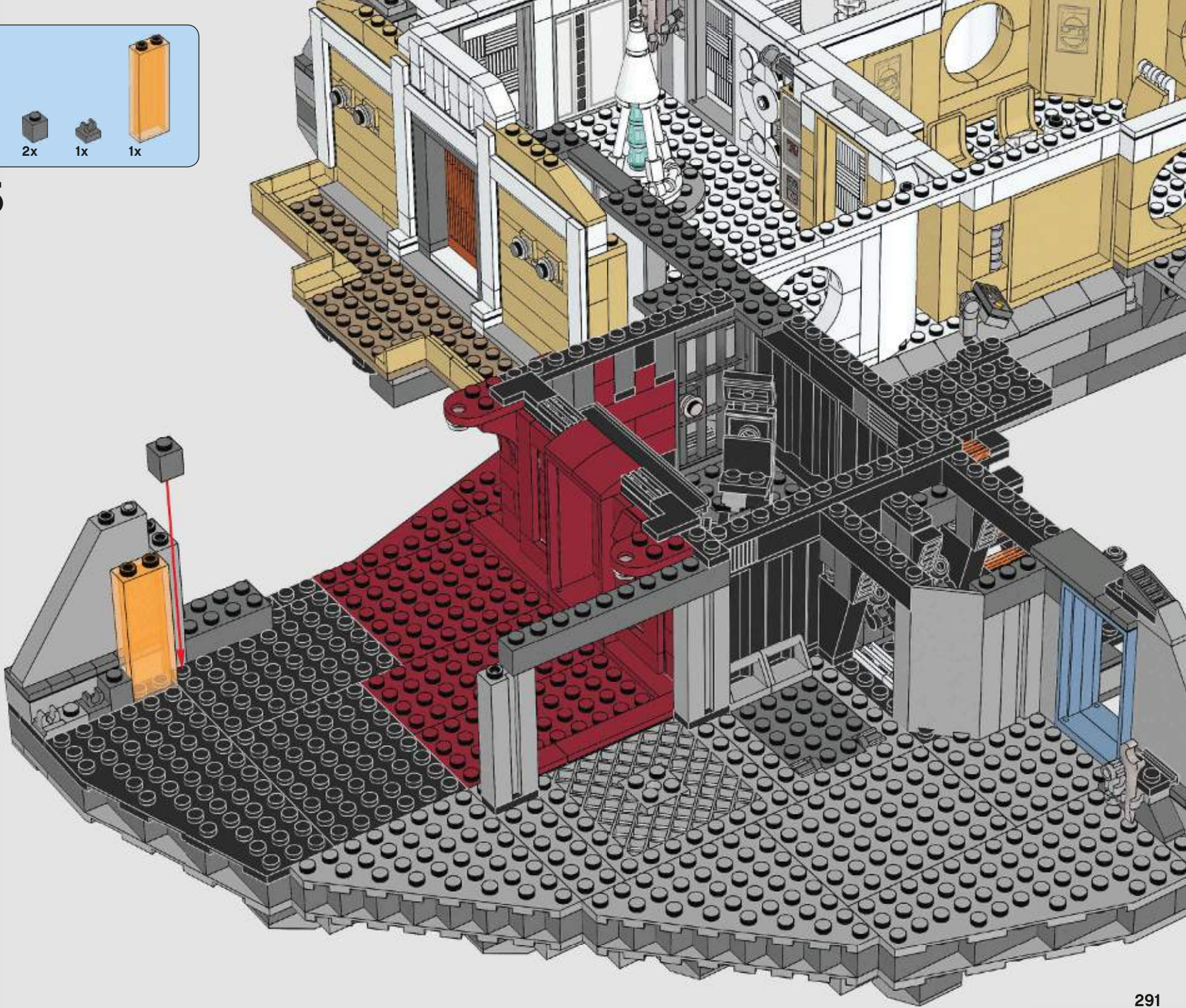



236

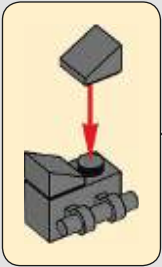
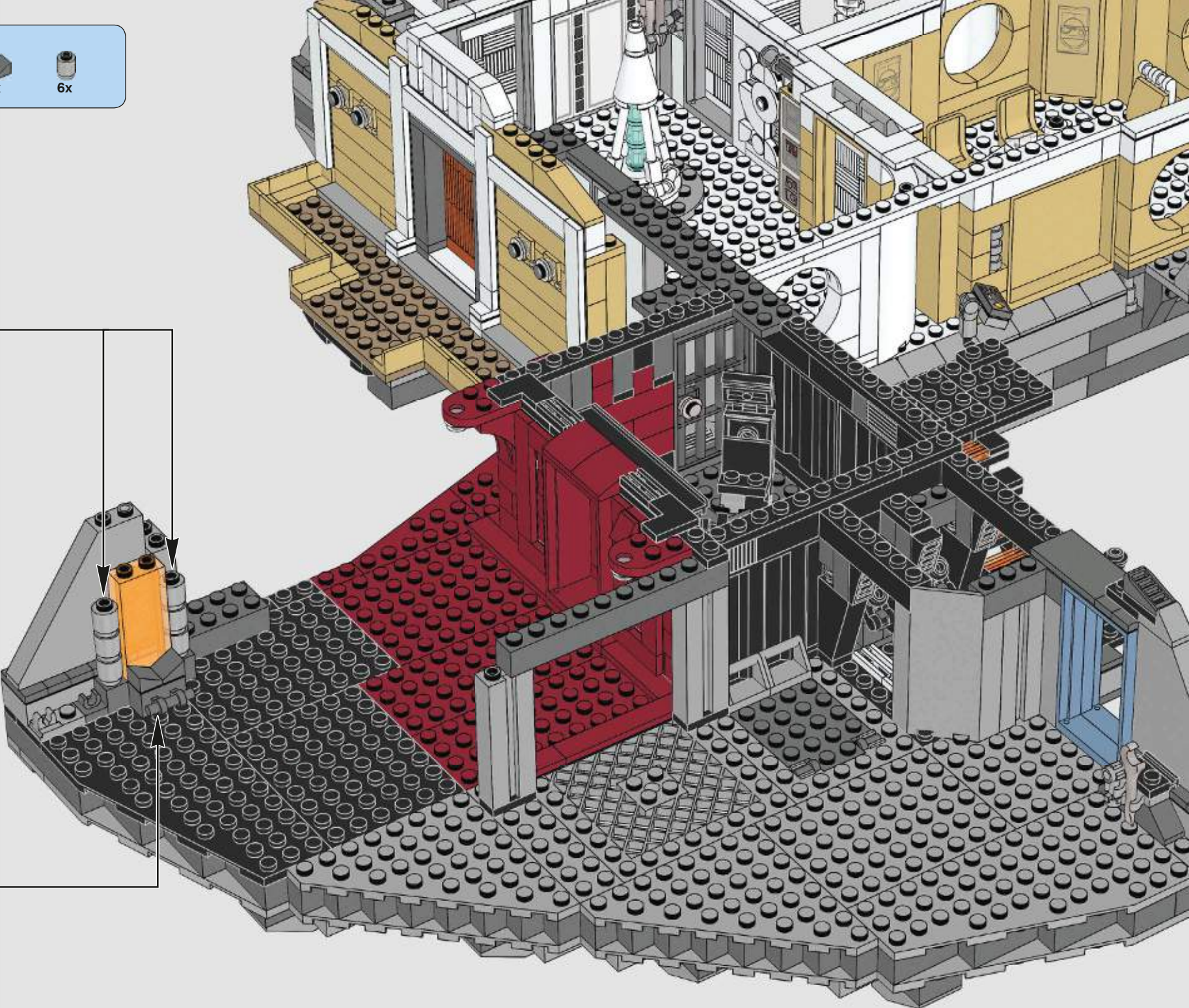
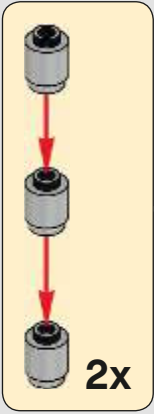

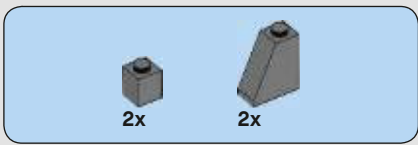

237

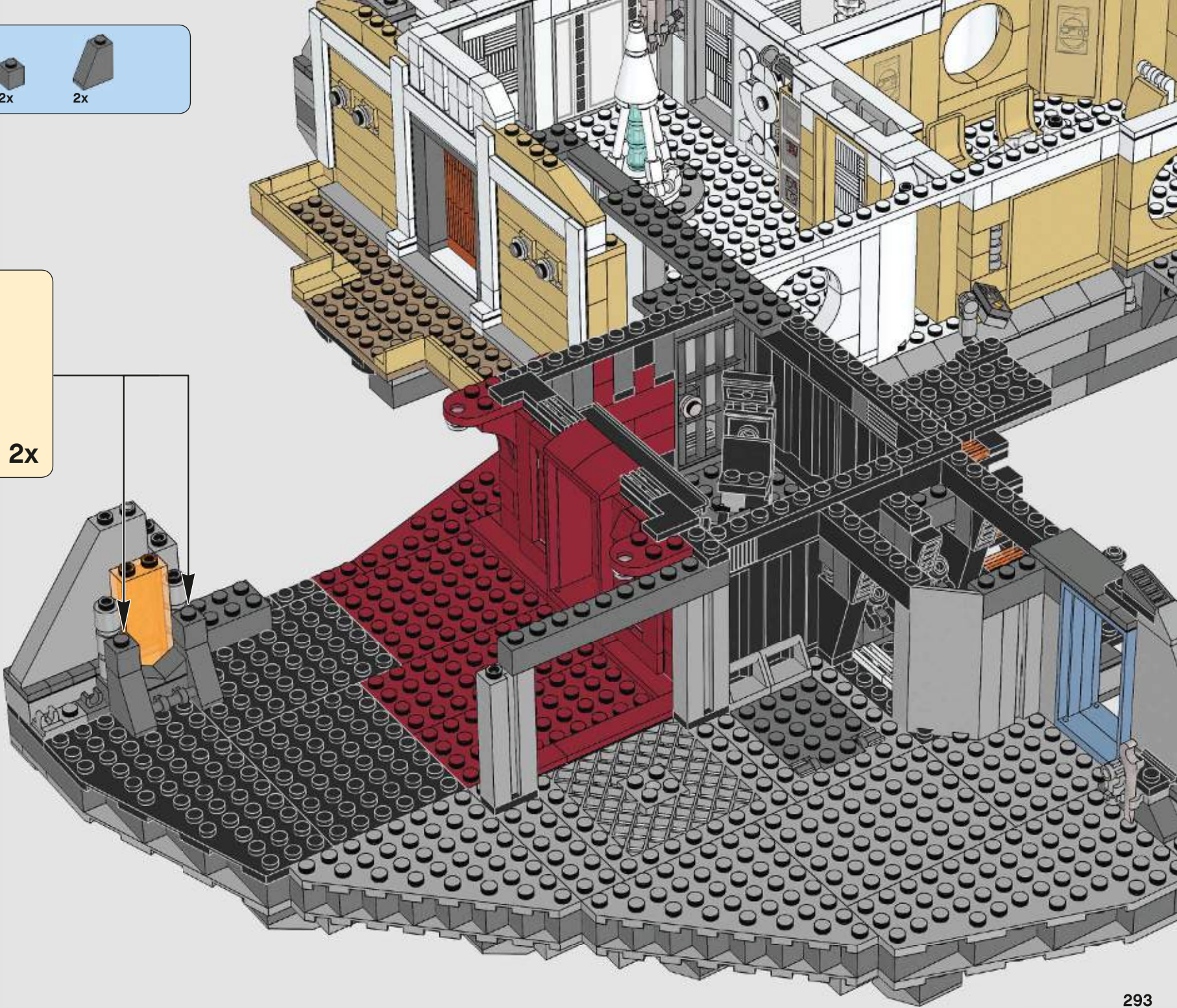
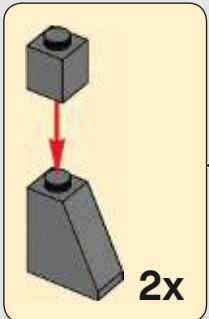

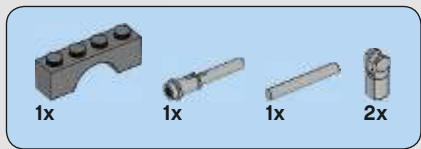

238

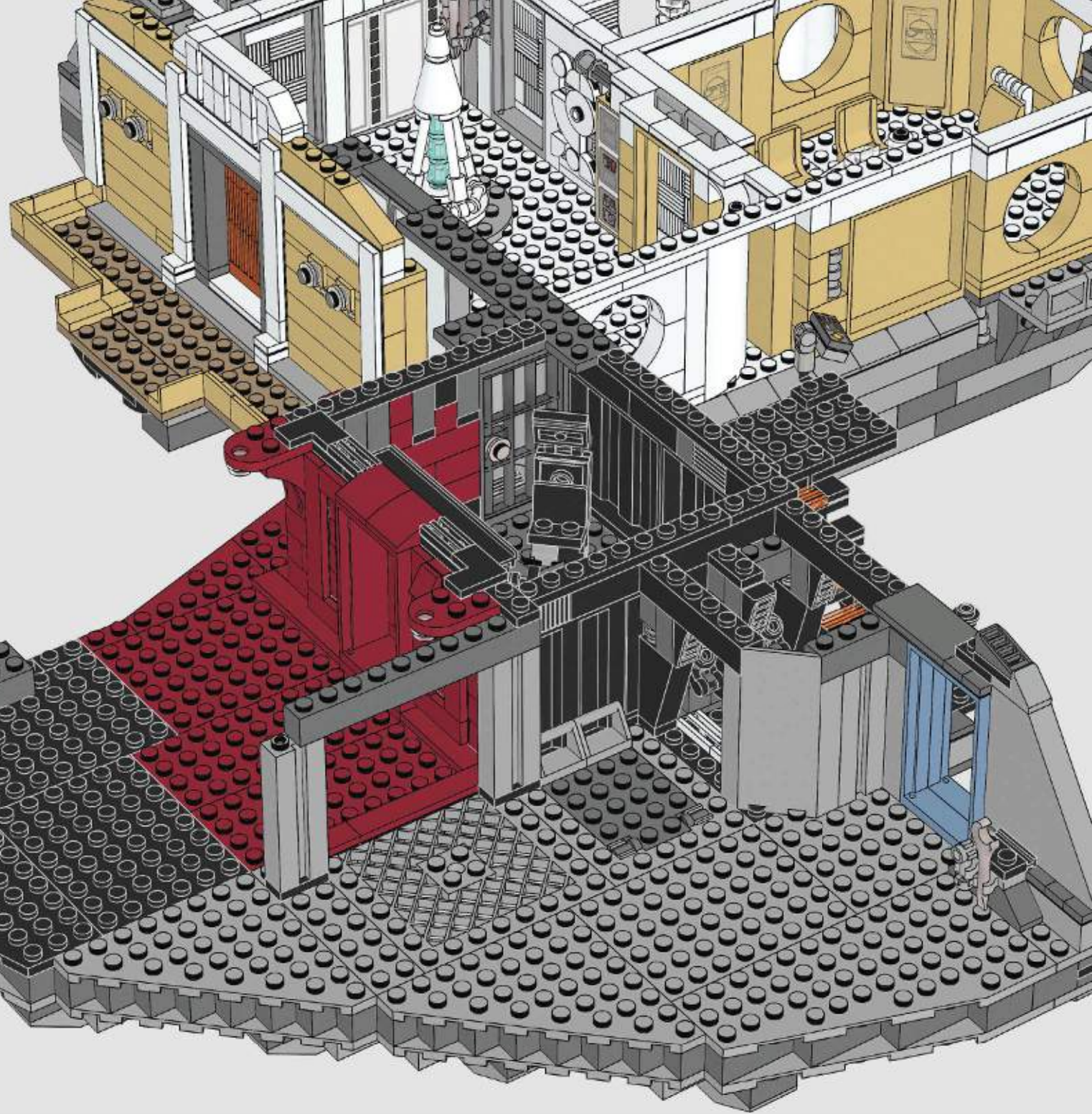
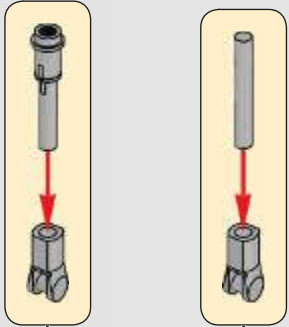

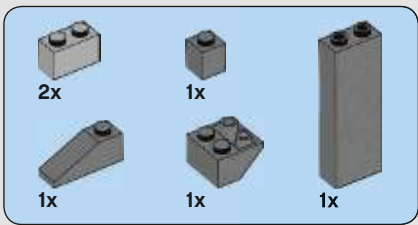

239

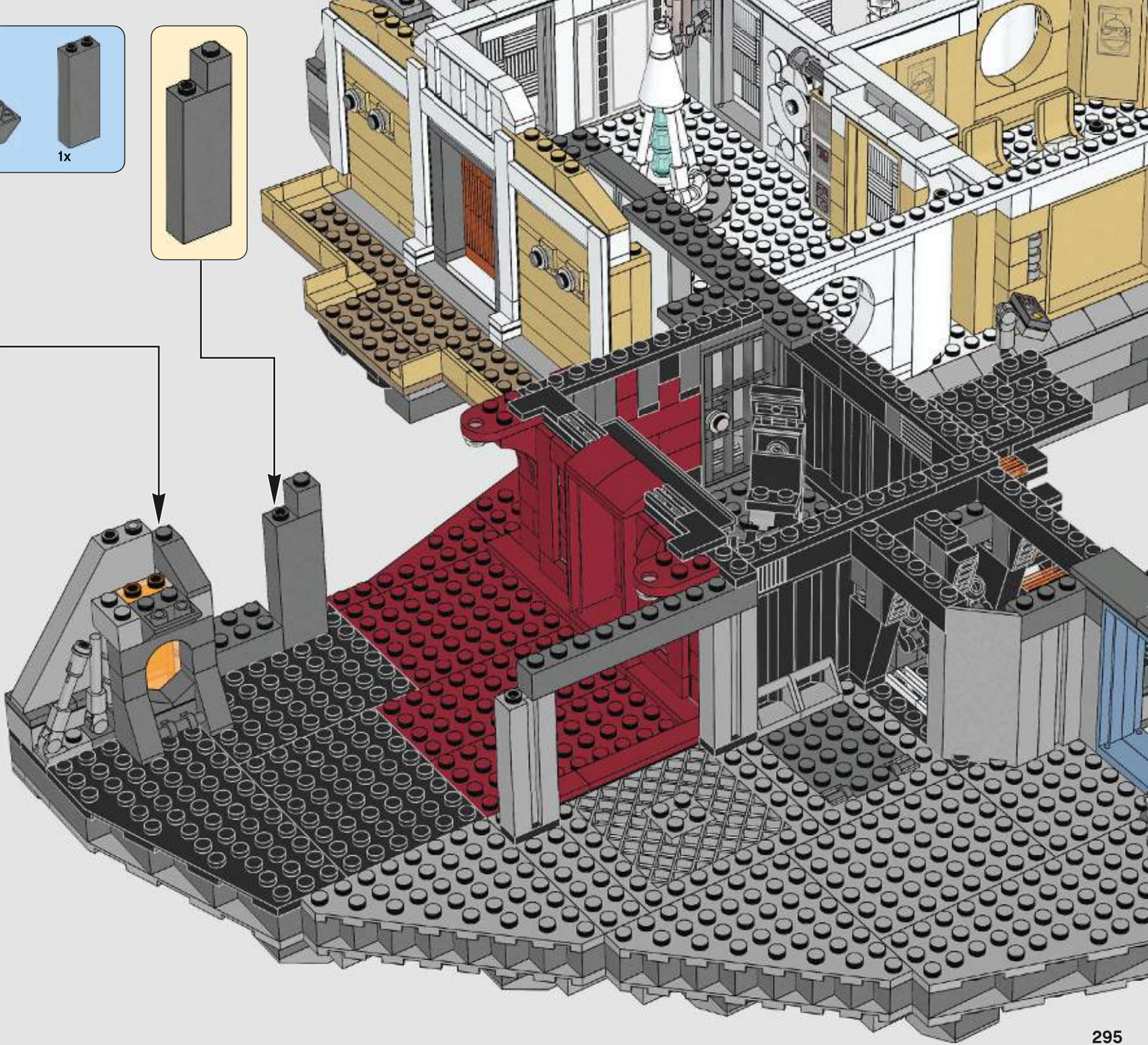
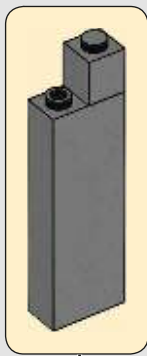
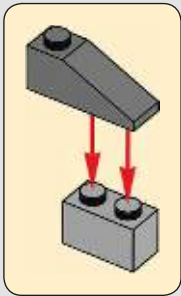

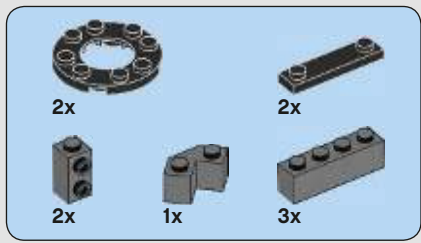

240

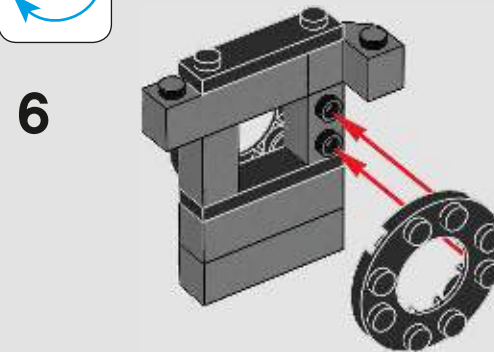
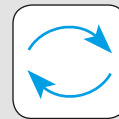
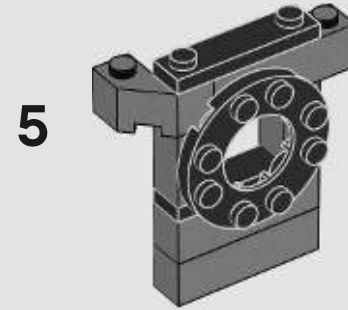
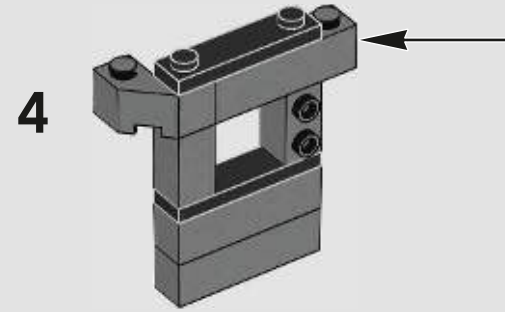
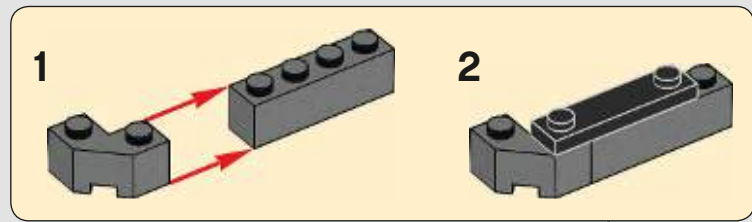
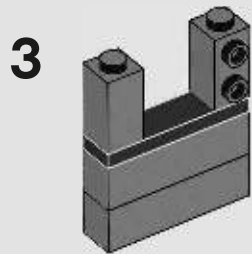
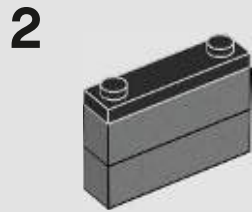
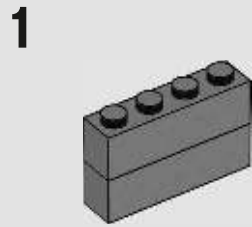

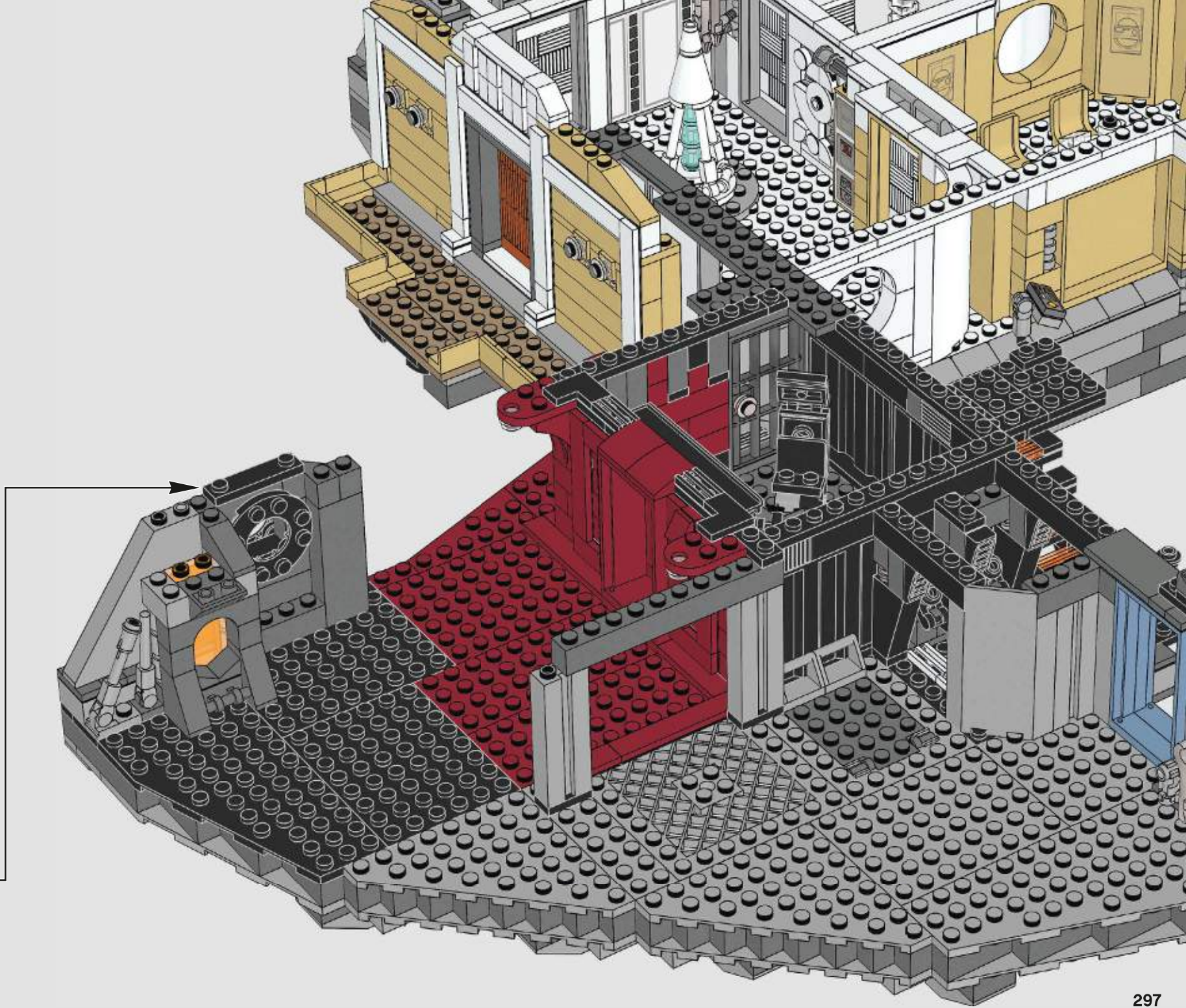

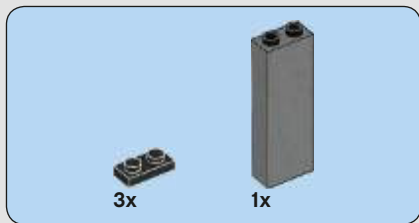

241

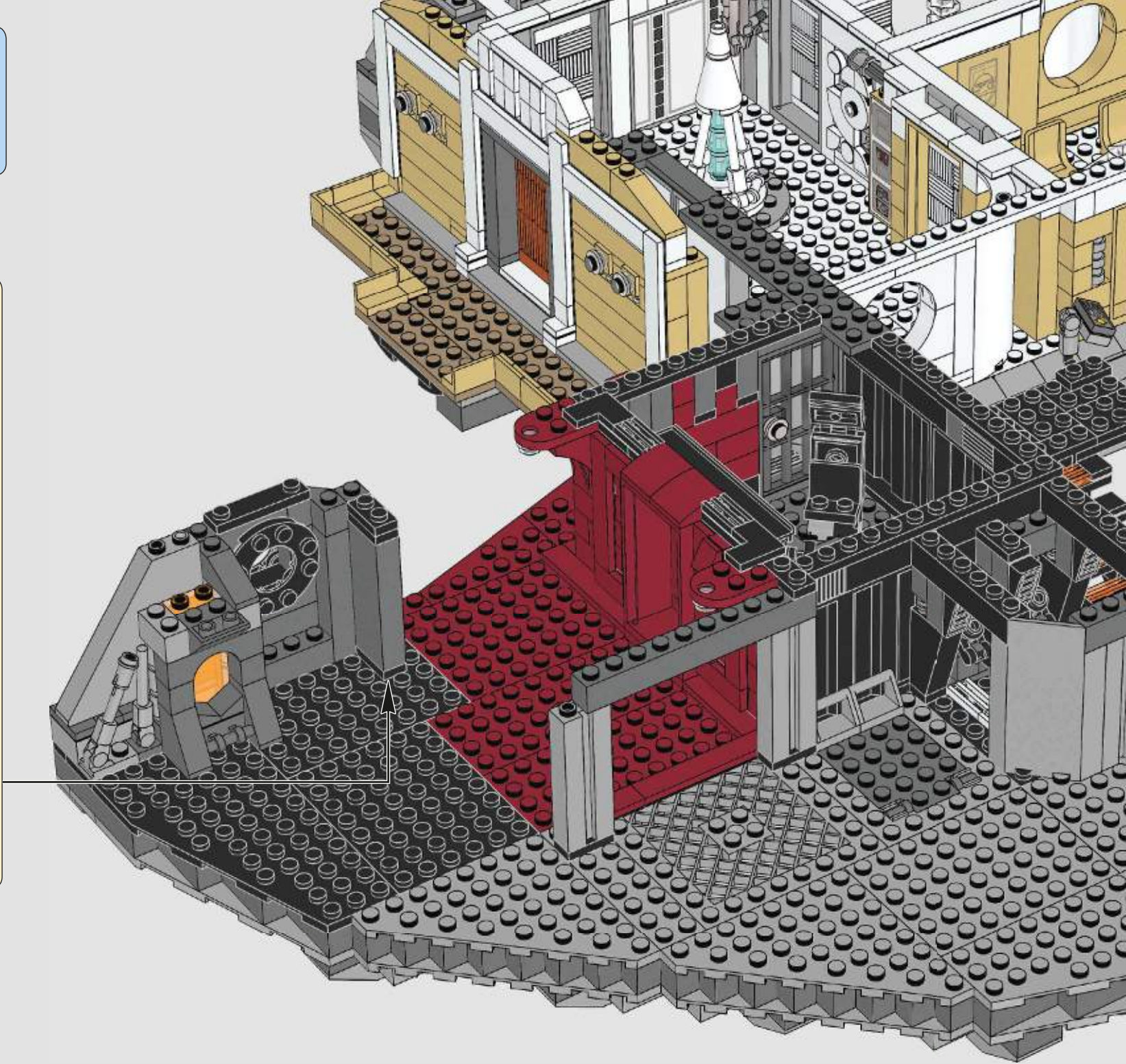
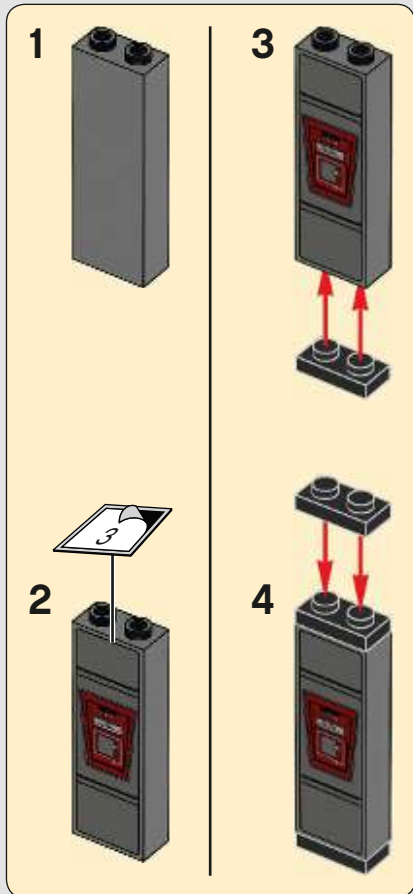

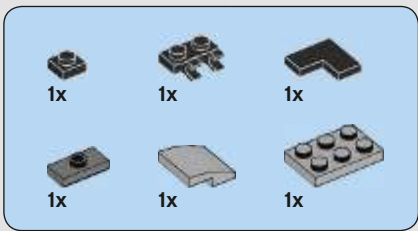

242

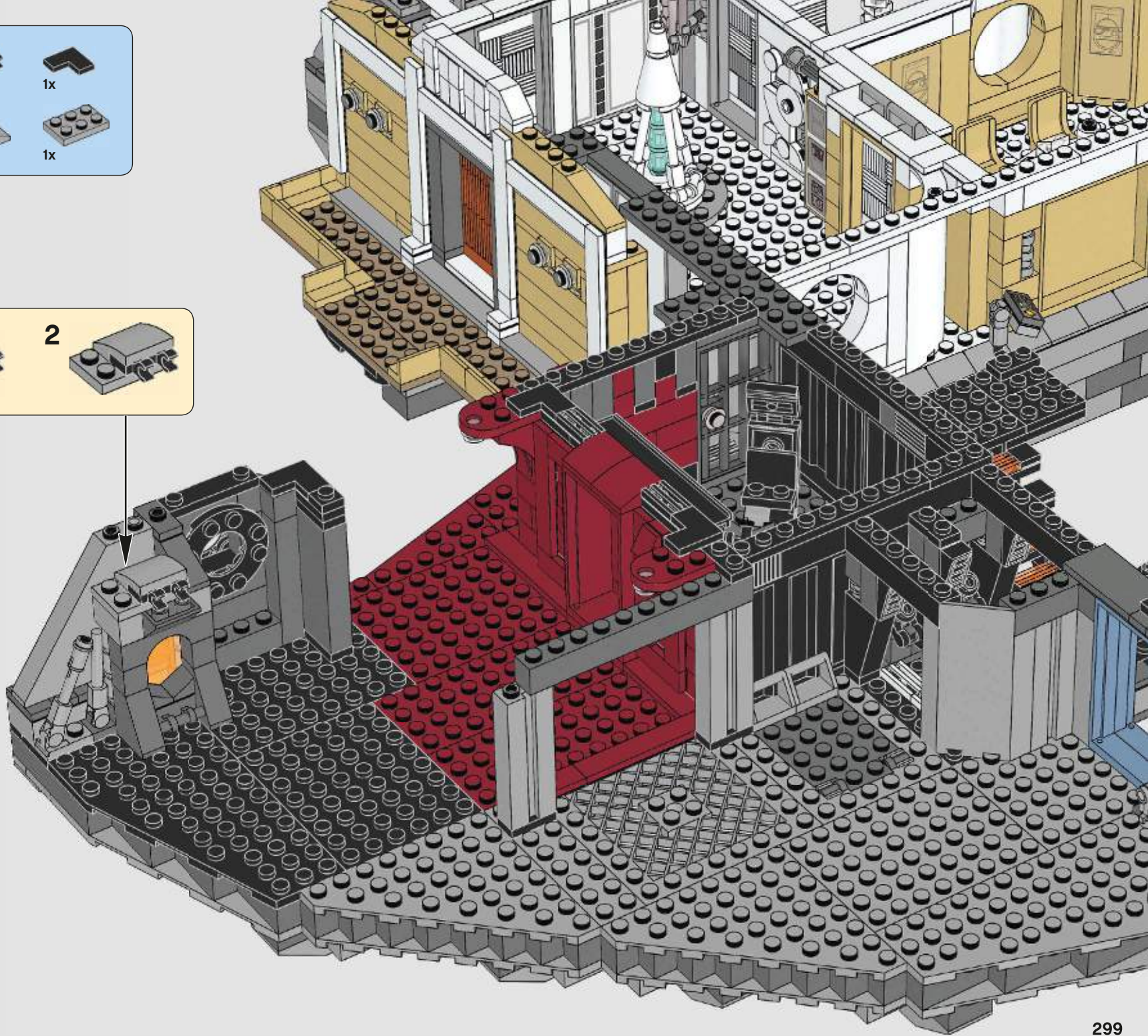
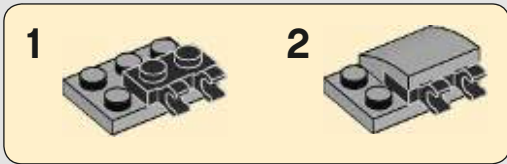



243

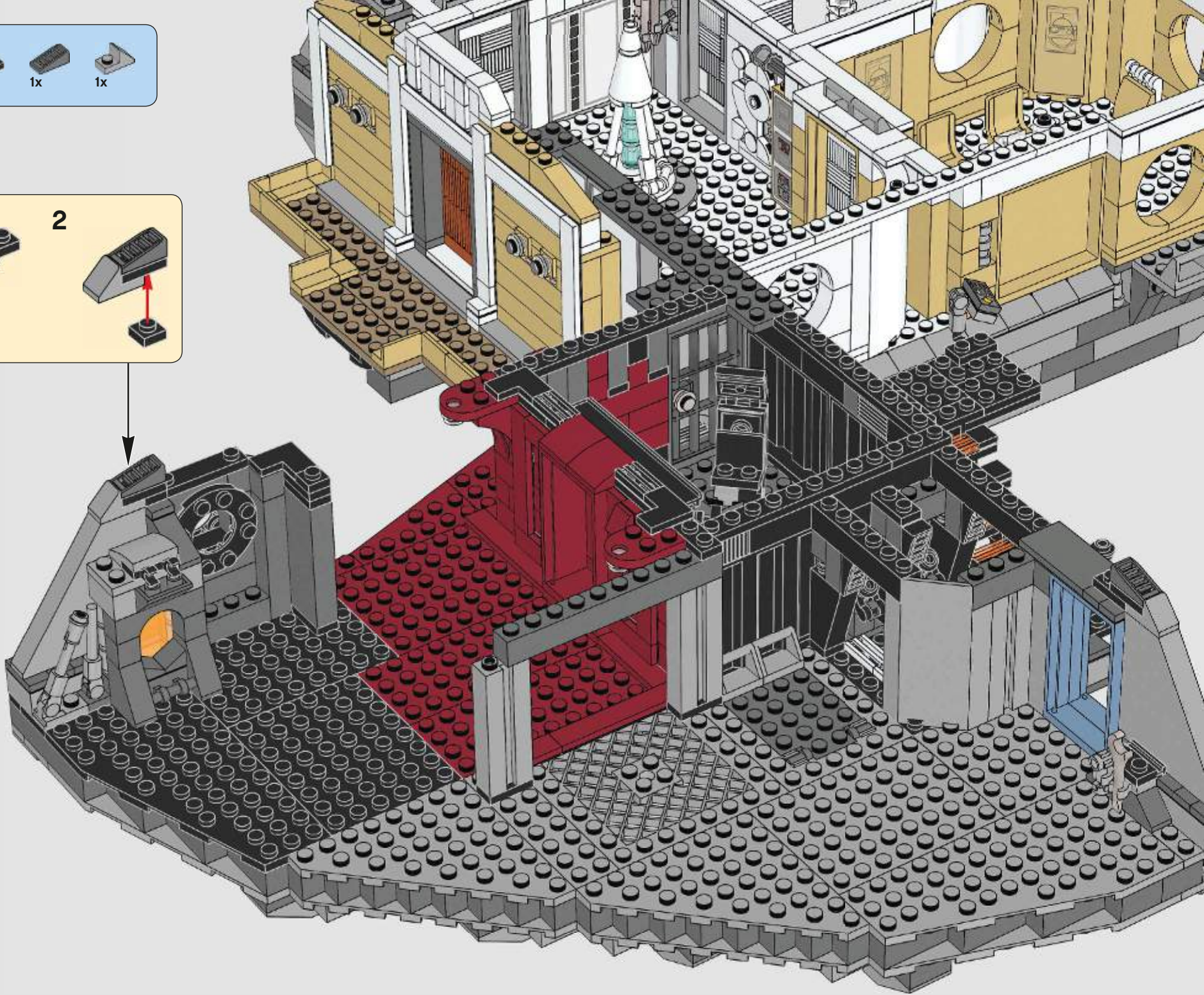
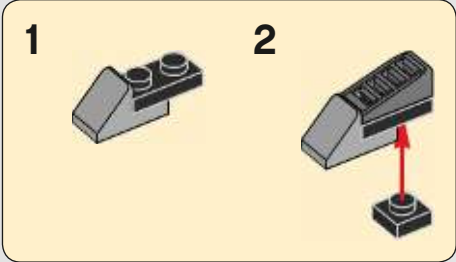

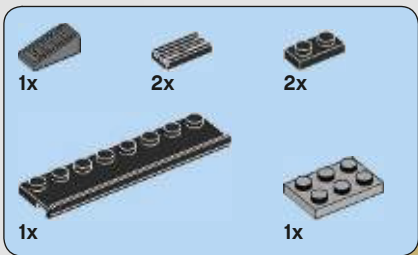

244

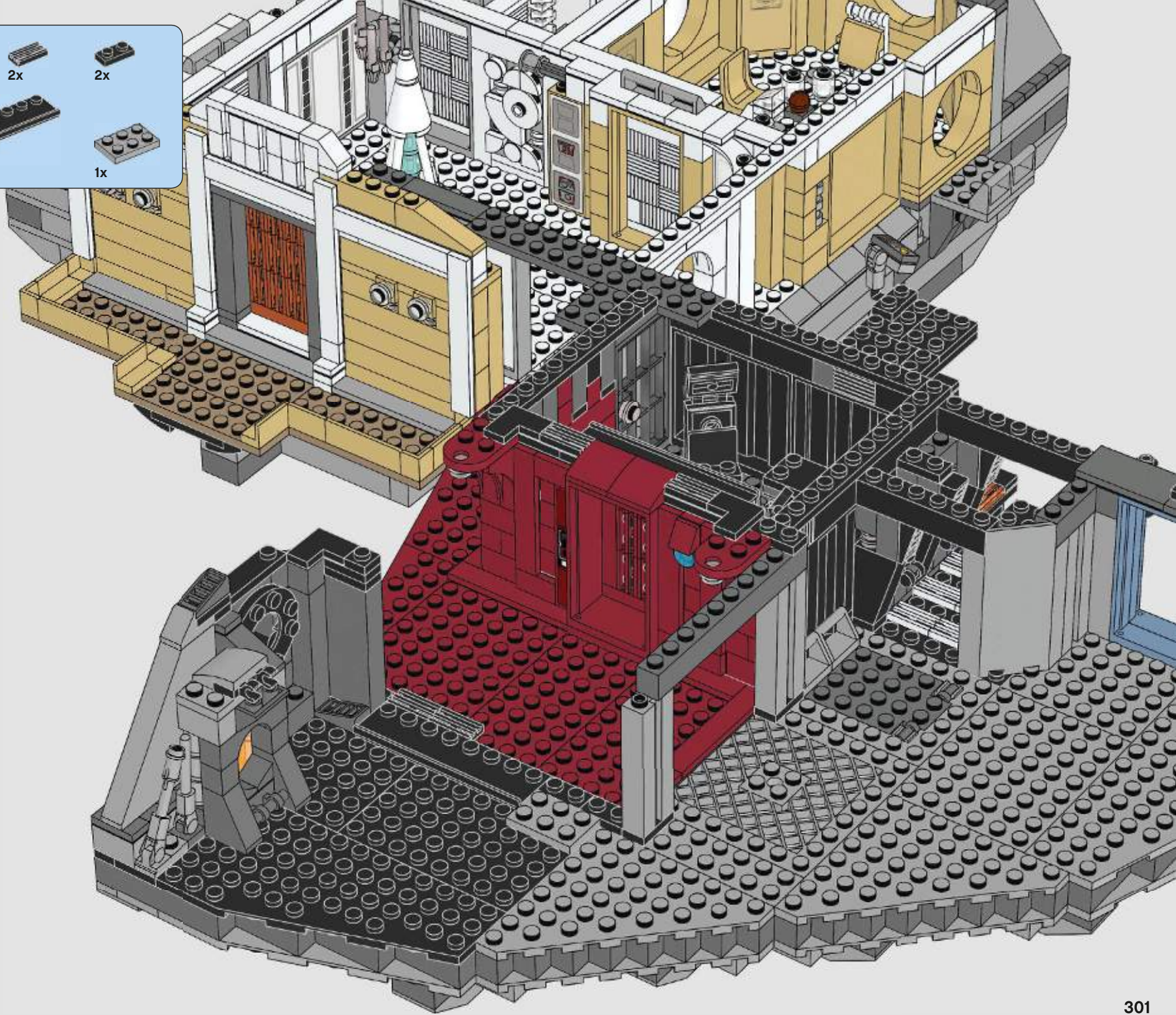

8x  2x 

245

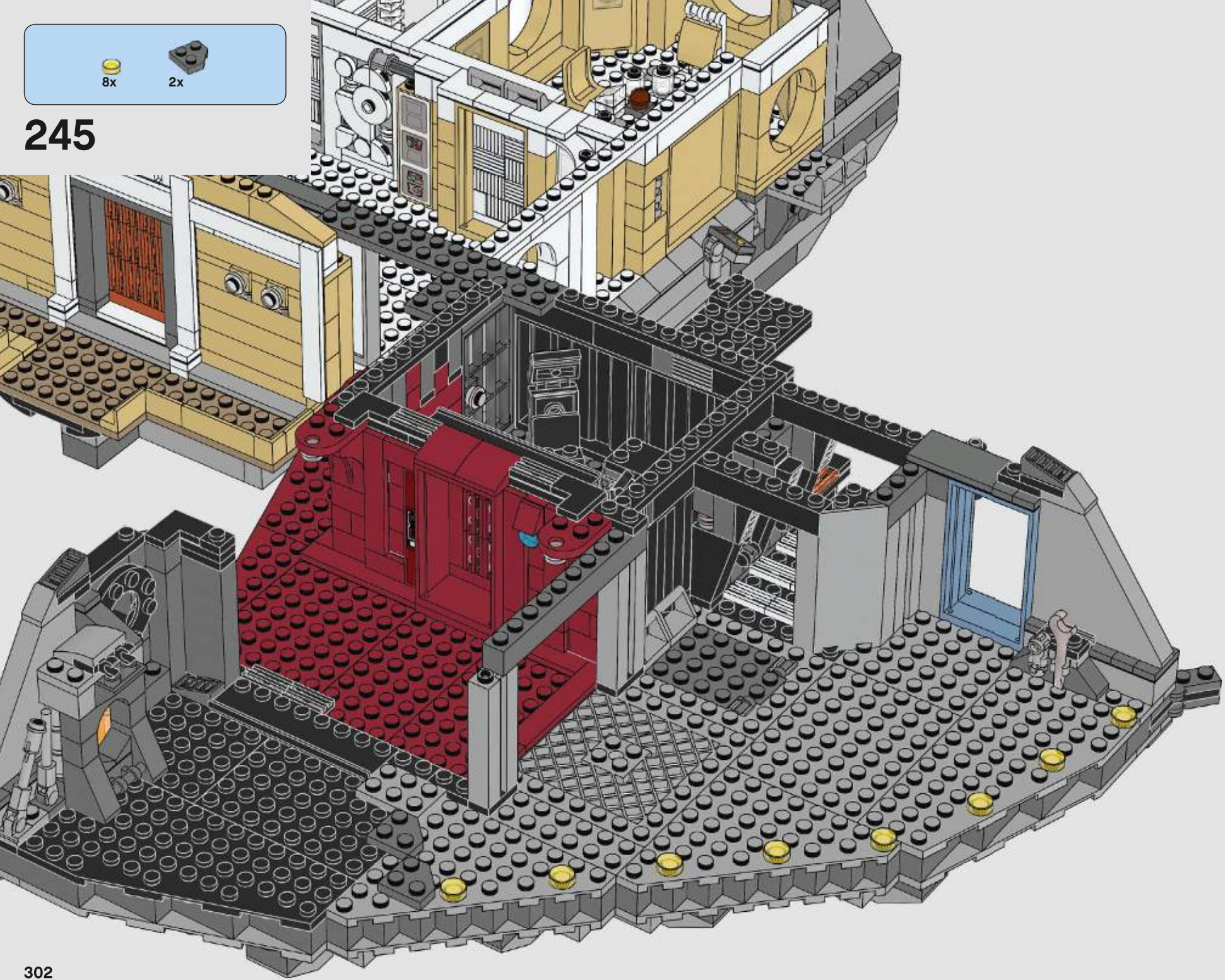

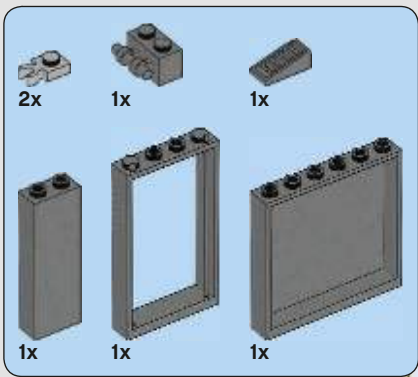

246

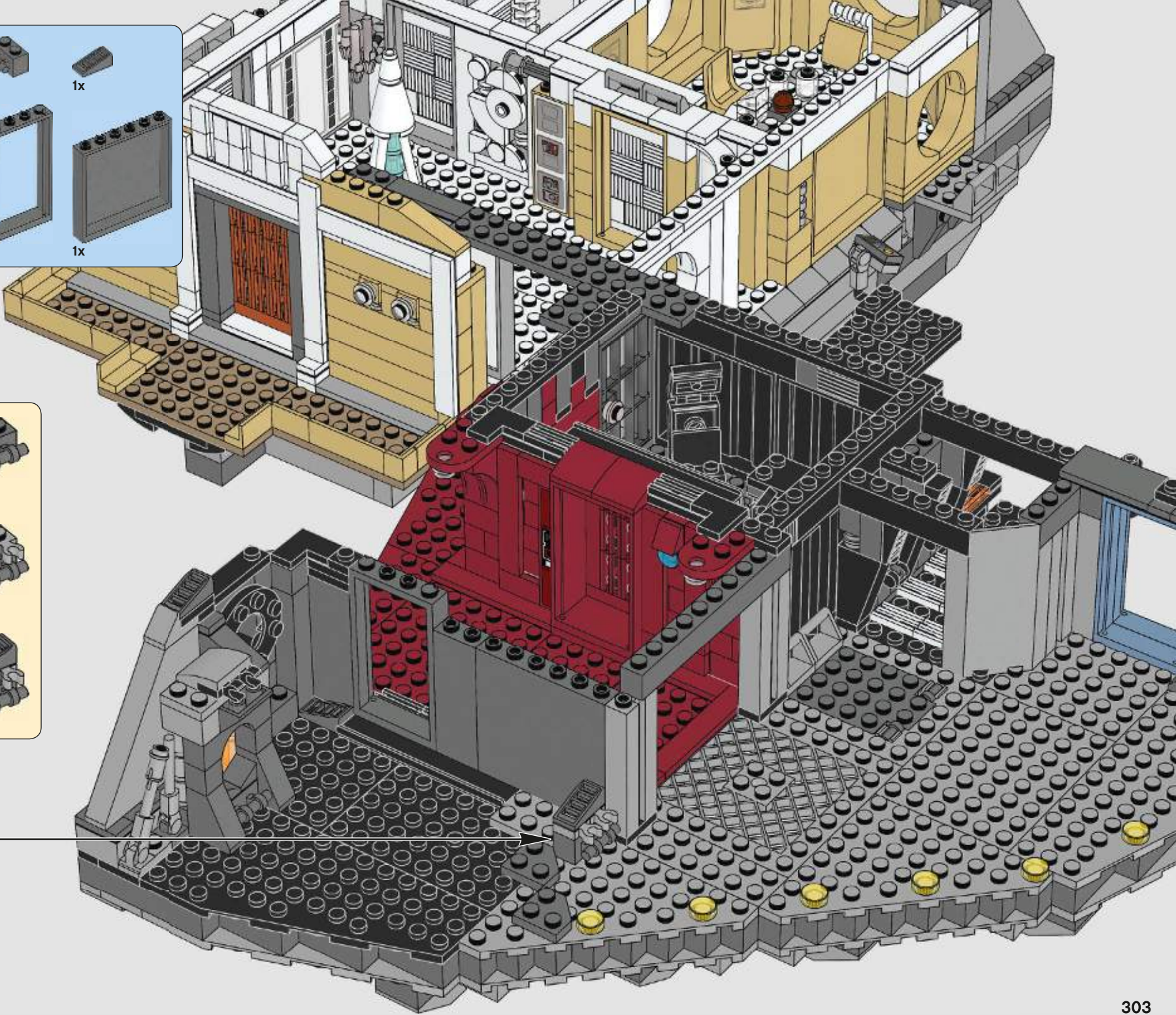
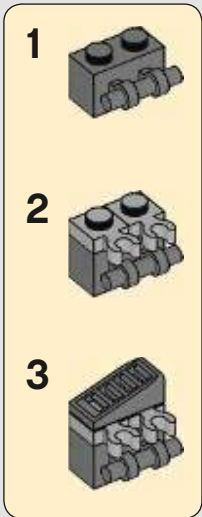

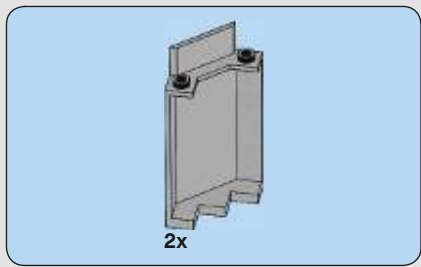

247

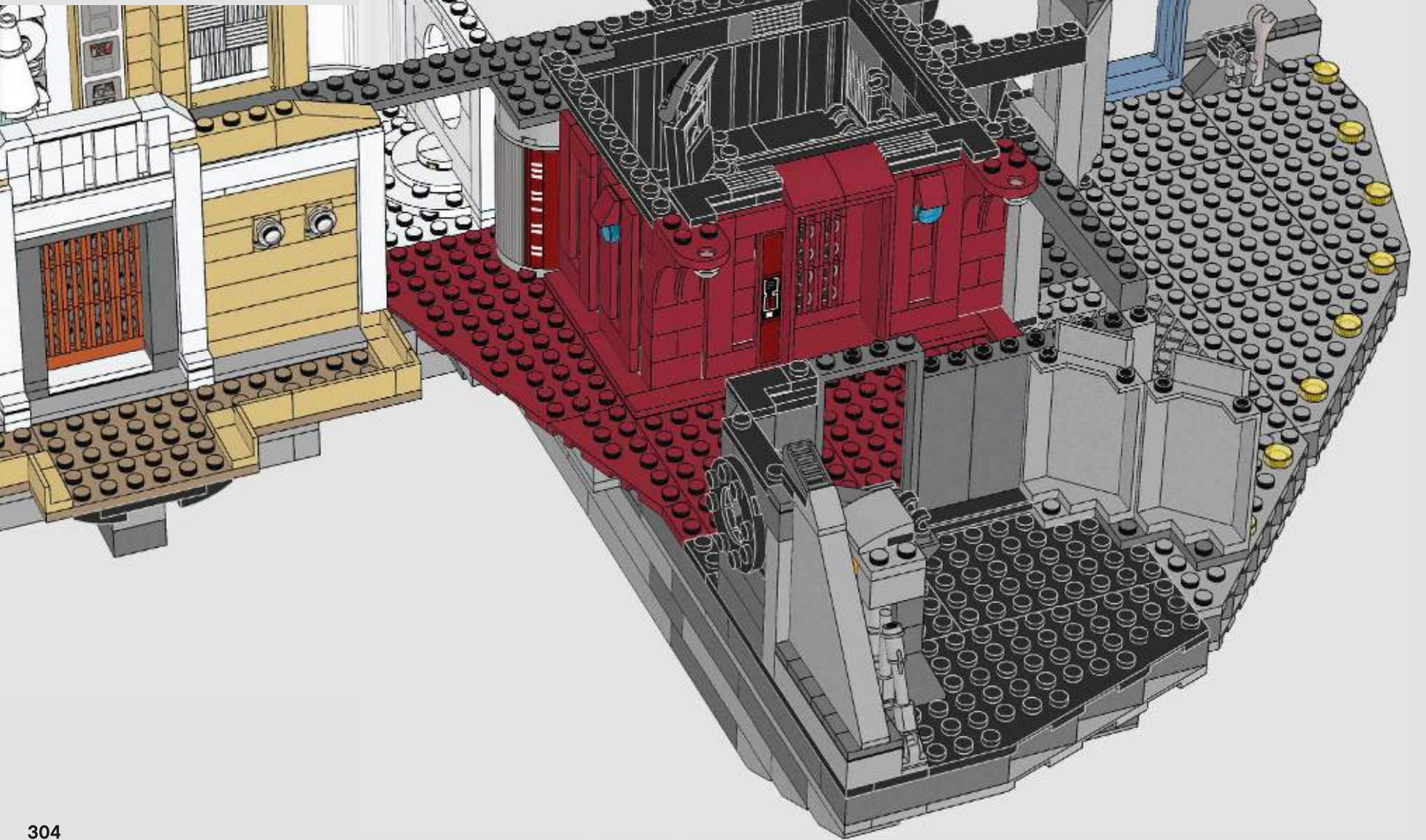

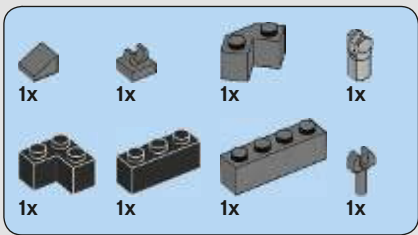

248

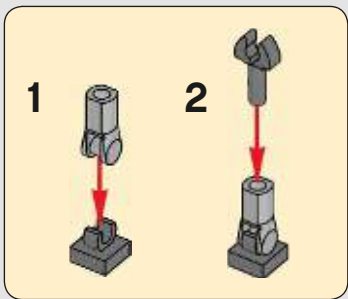
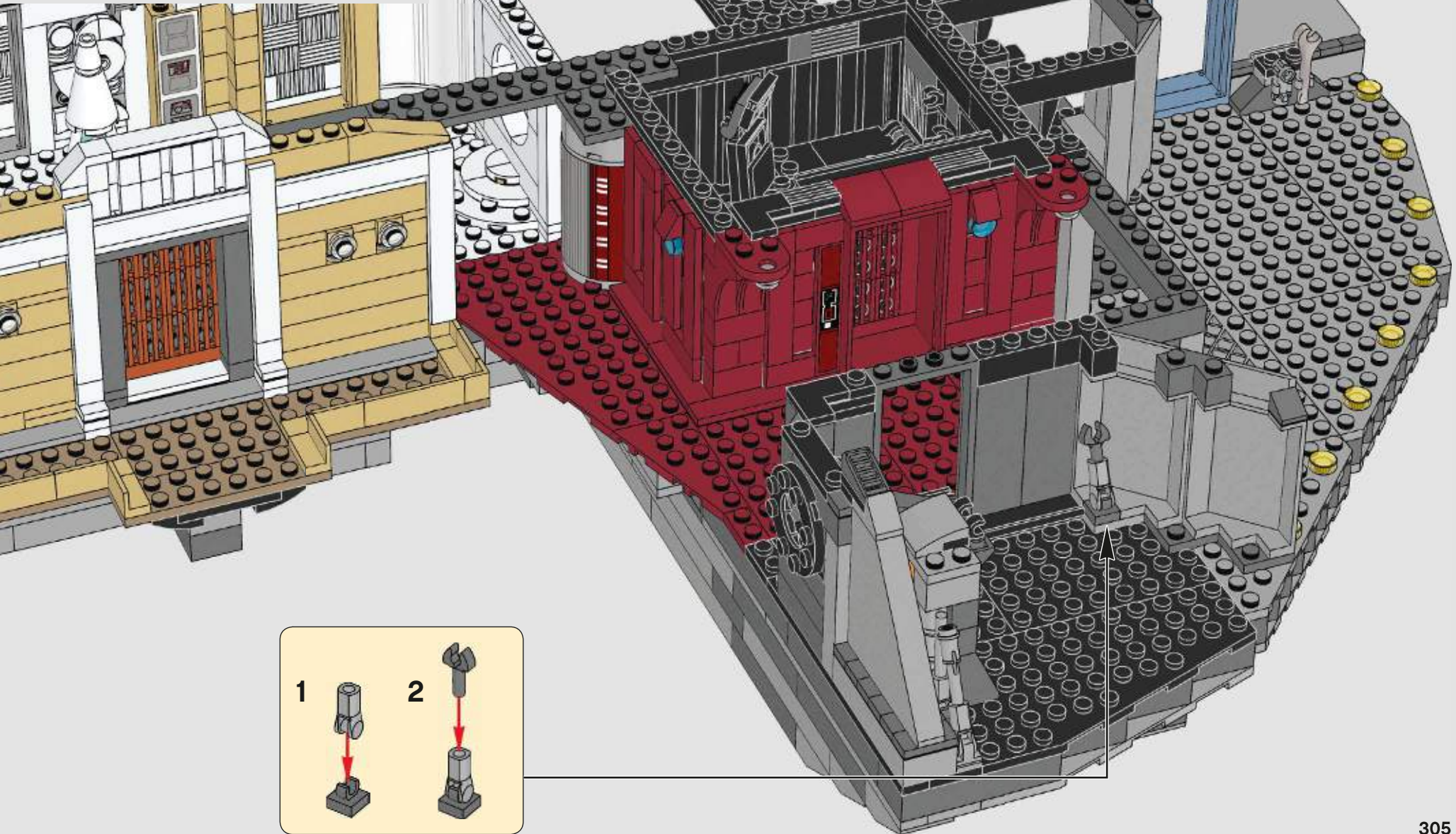

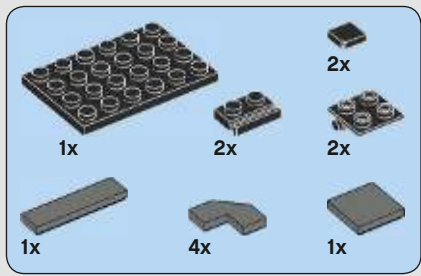

249

1

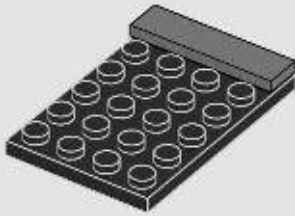

2

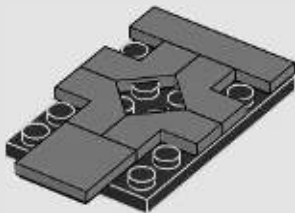

3

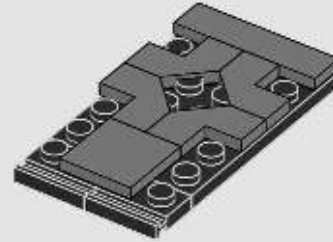

4

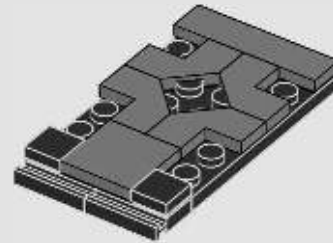

5

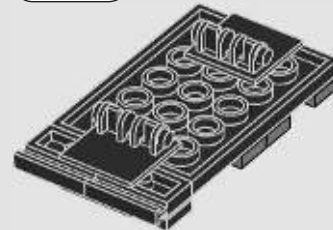
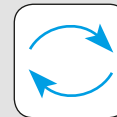



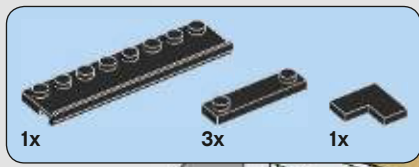

250

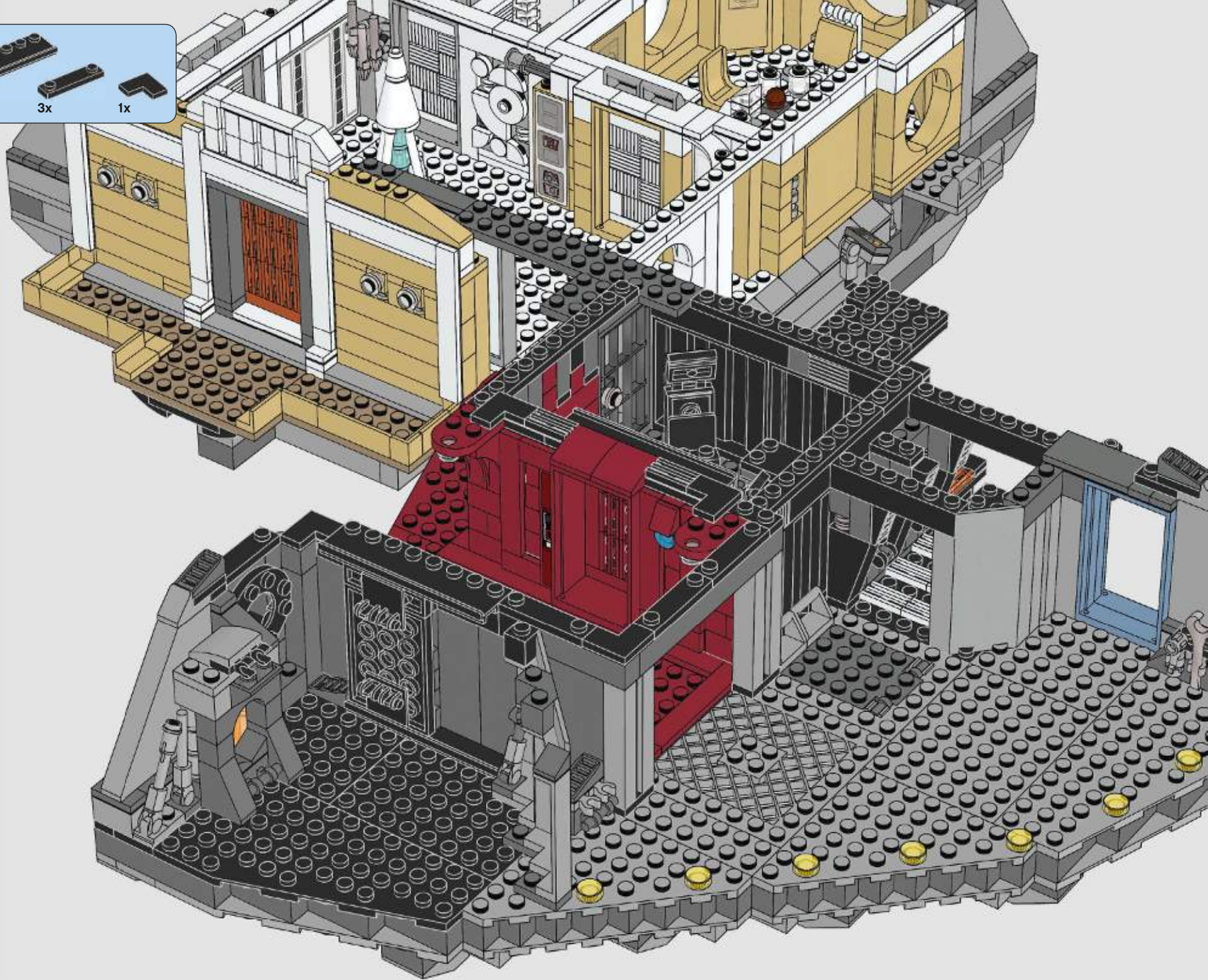

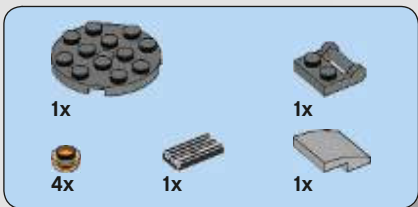

251

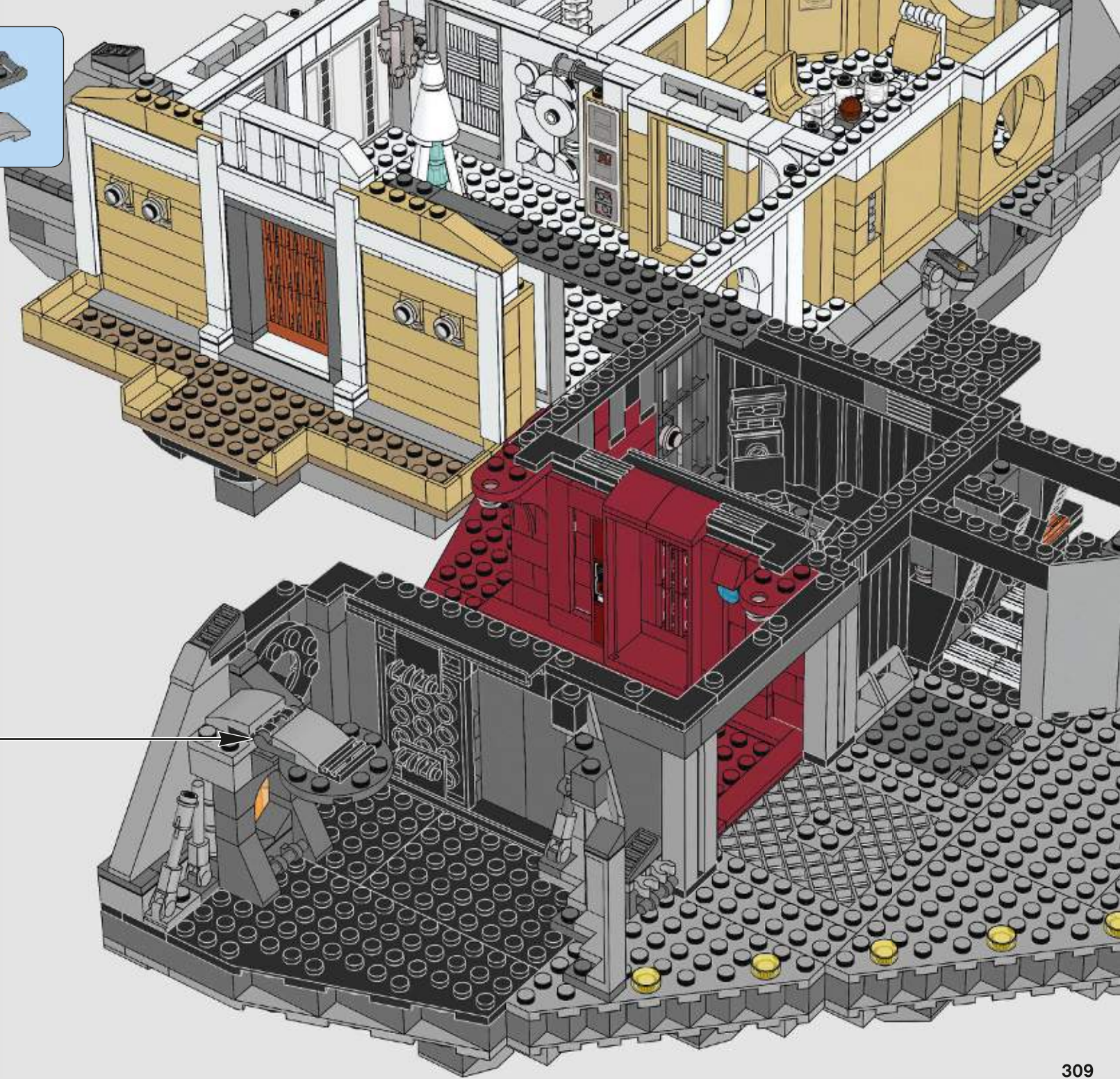
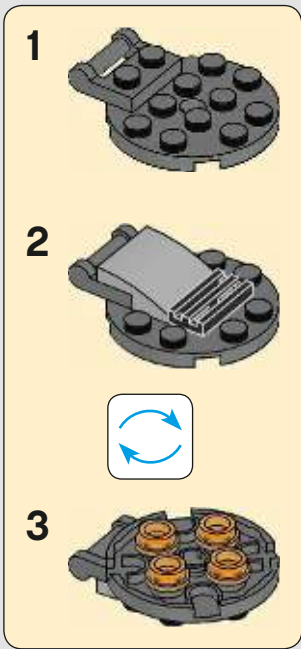

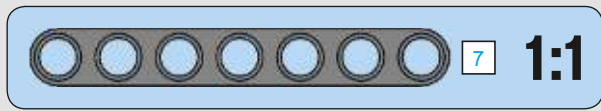
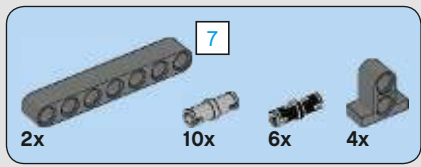

252

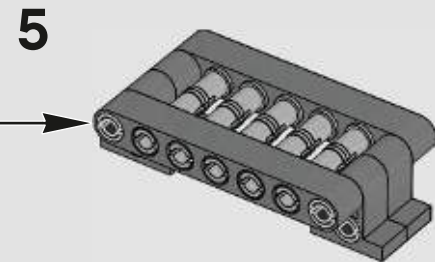
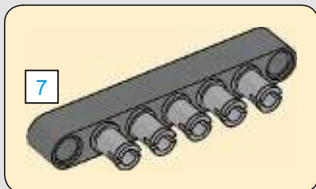
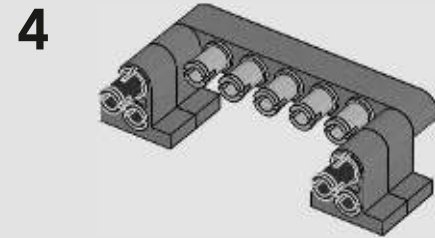
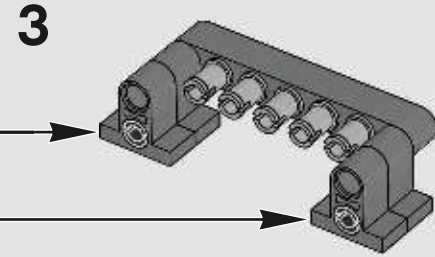
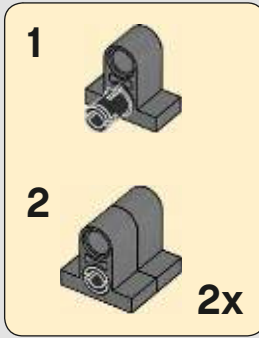
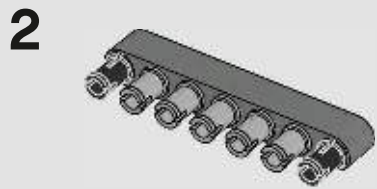
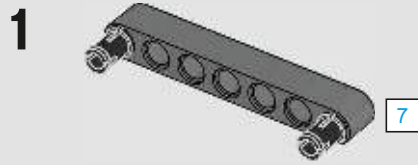

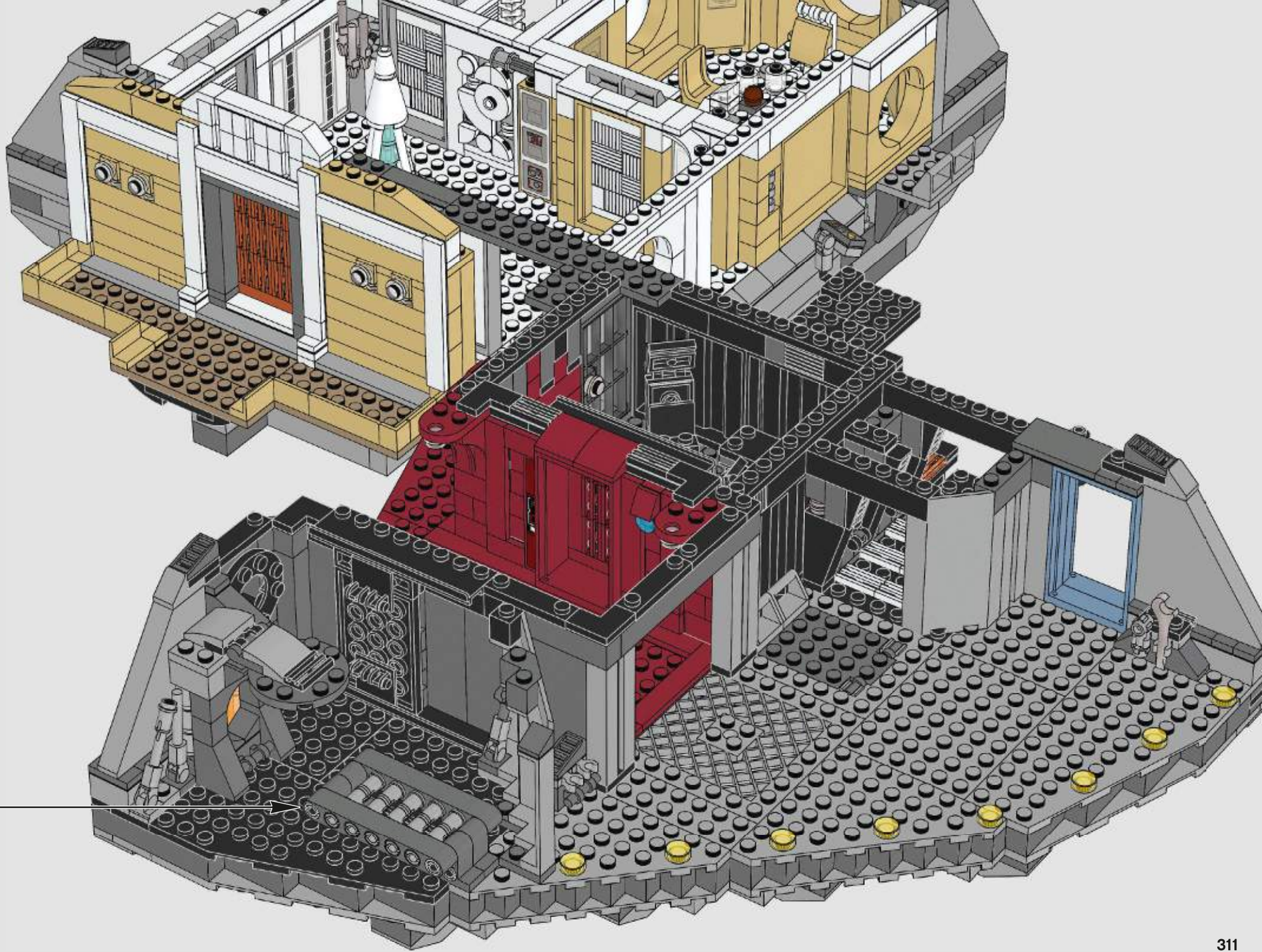

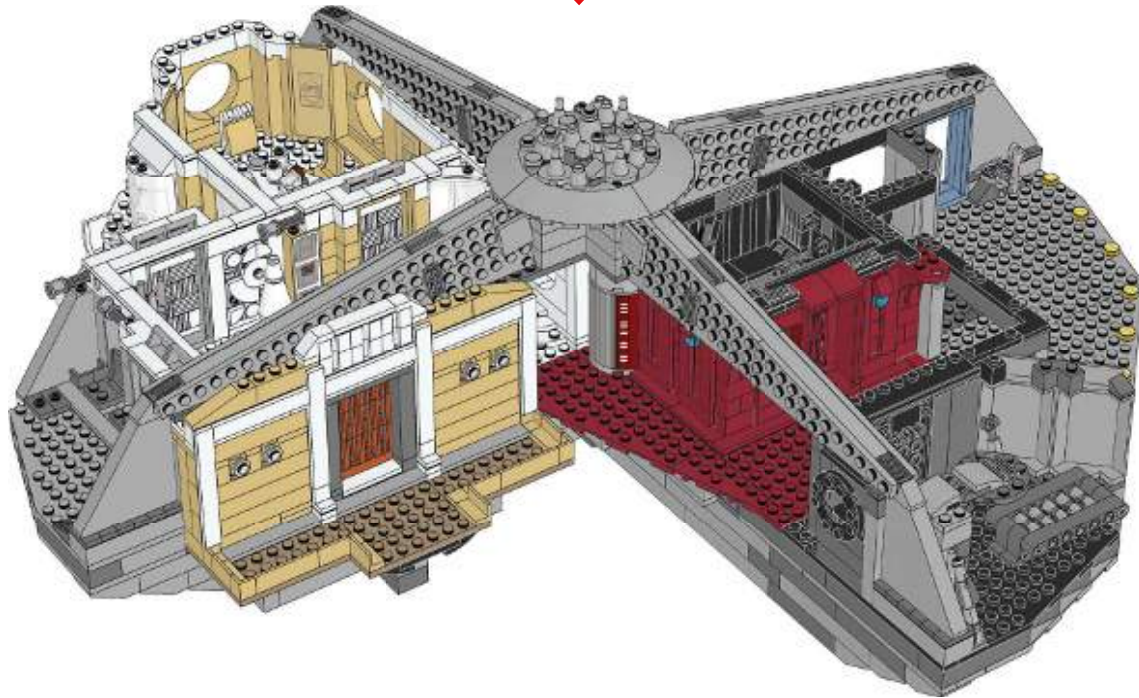

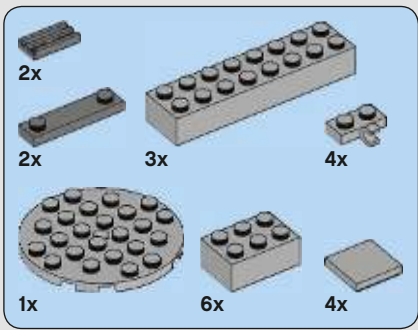

253

1

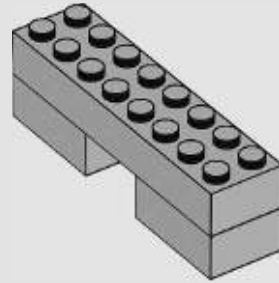

2

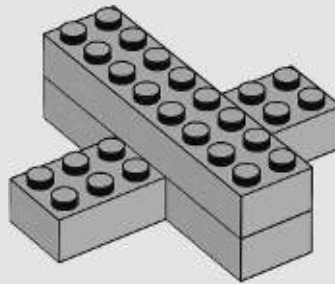

3

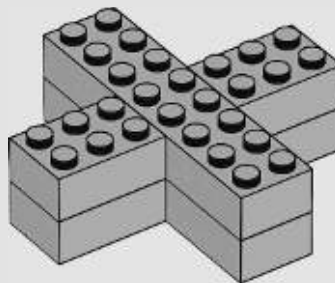

4

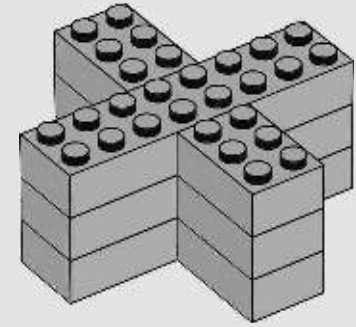

5

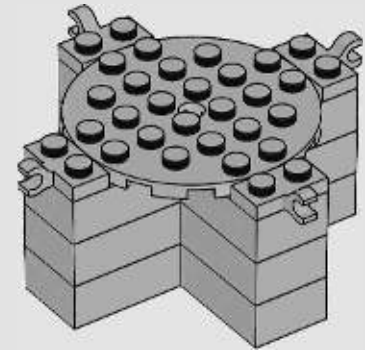

6

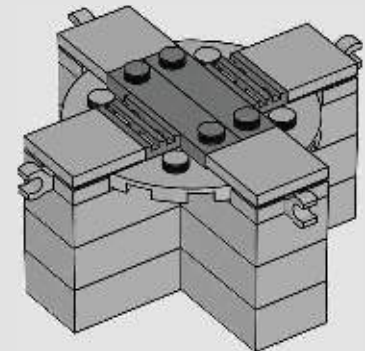

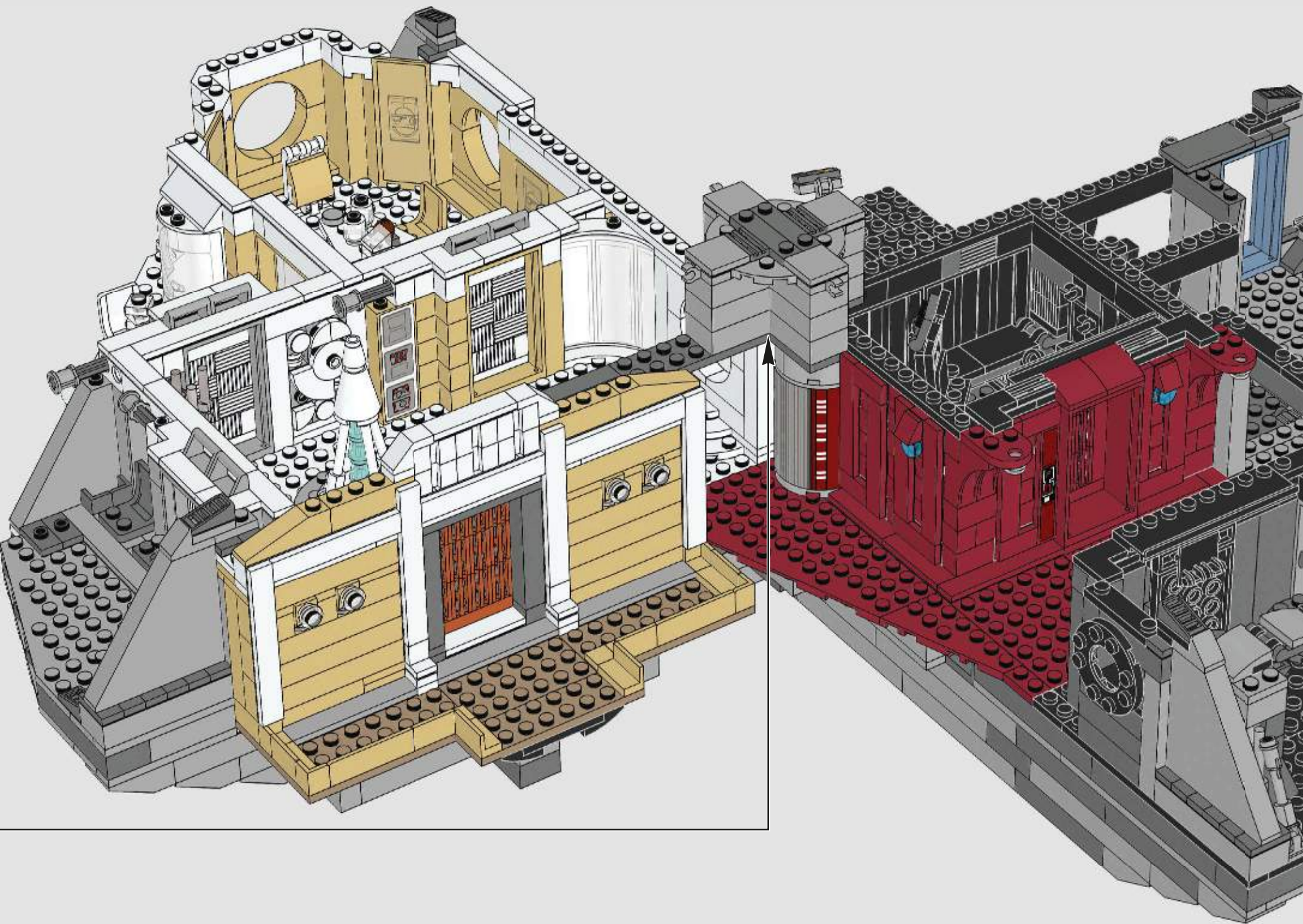

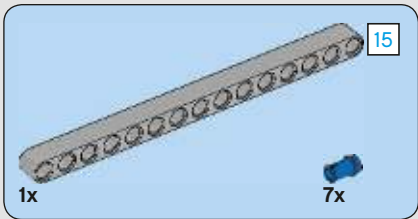
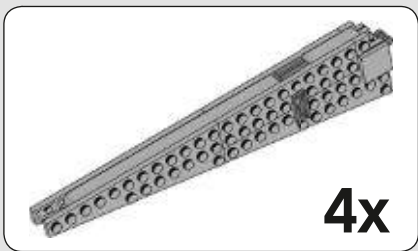

254

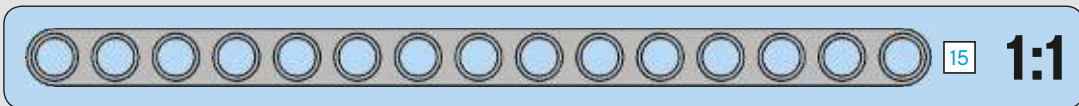
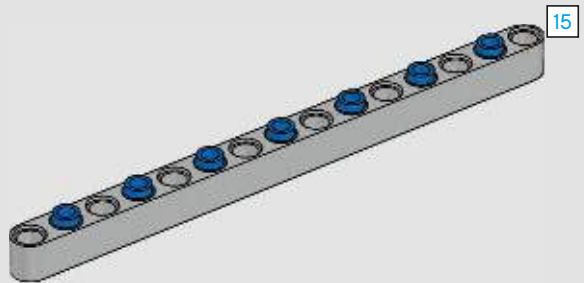

255

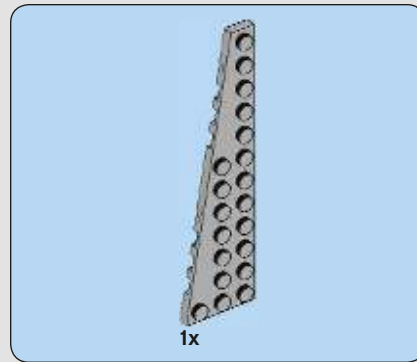
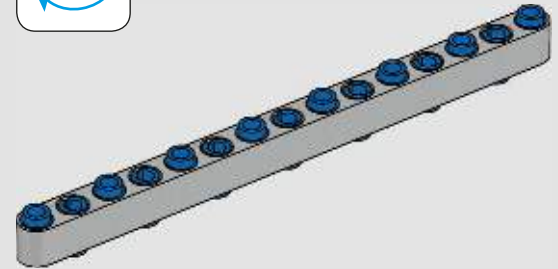
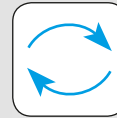

256

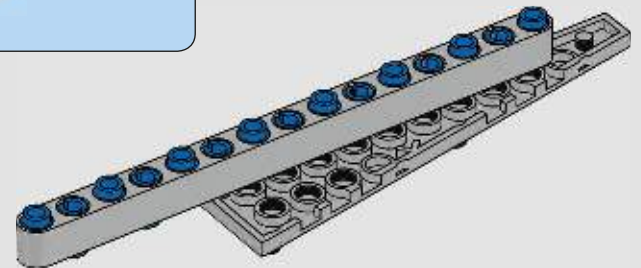

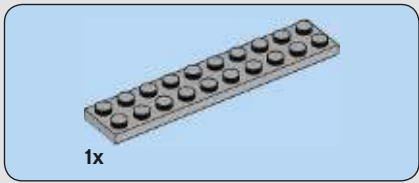

257

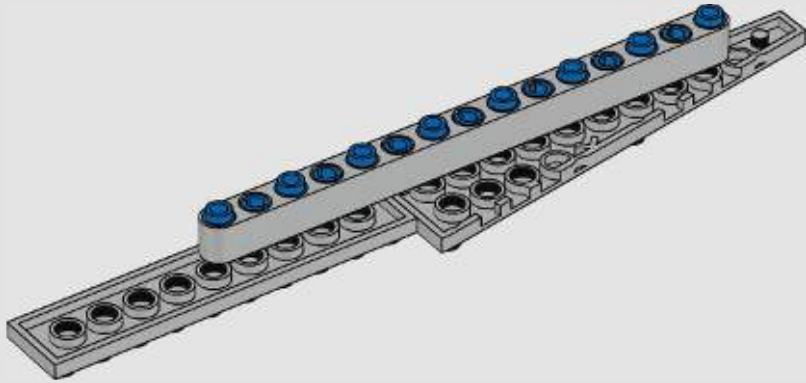

258

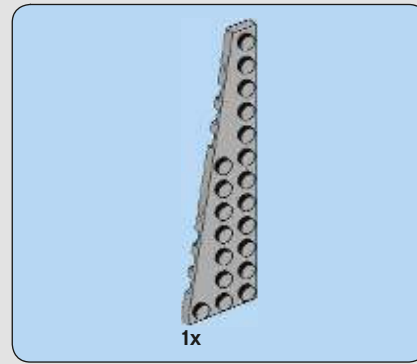
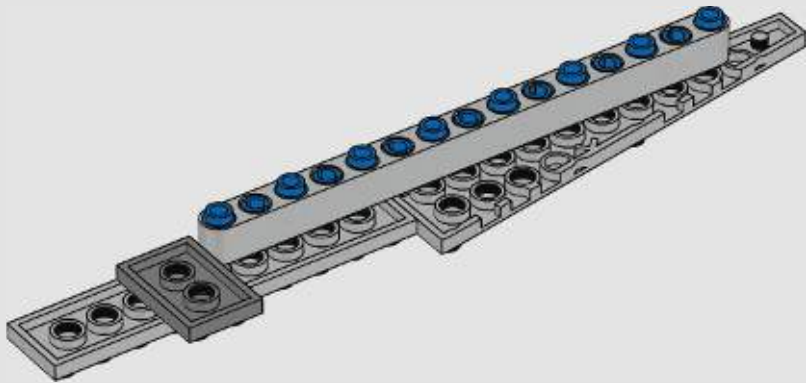

259

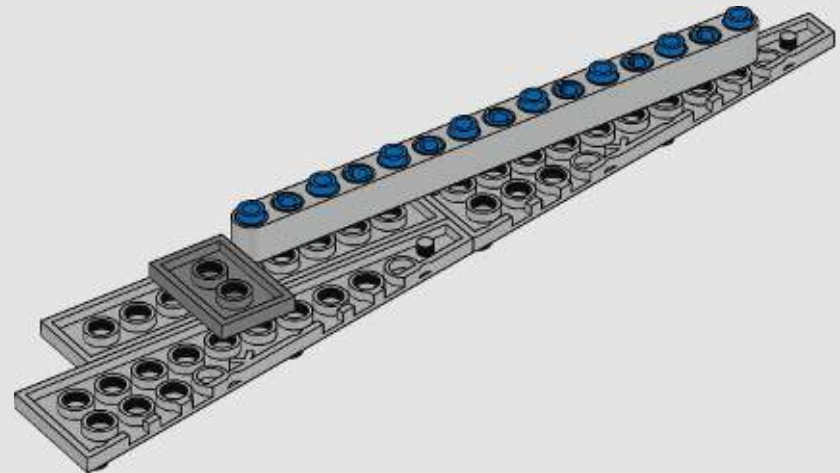

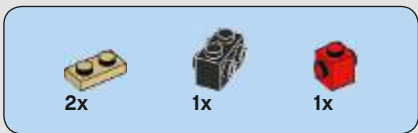

260

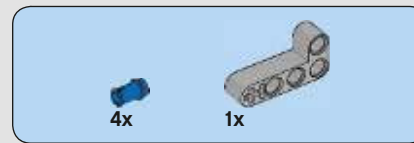
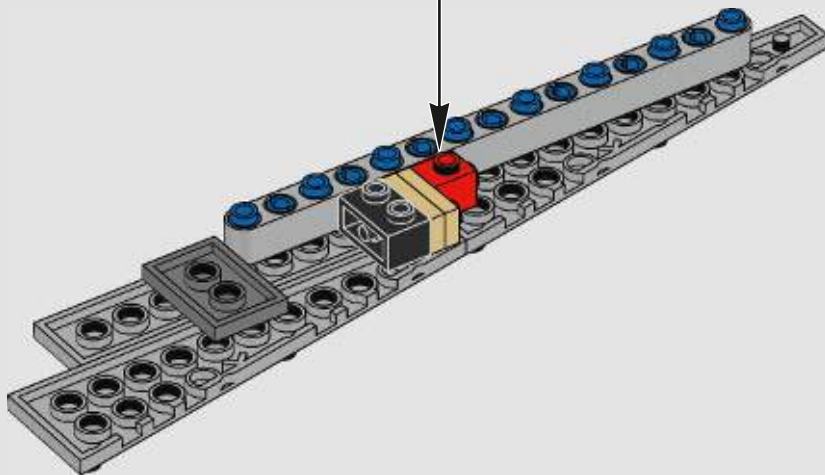
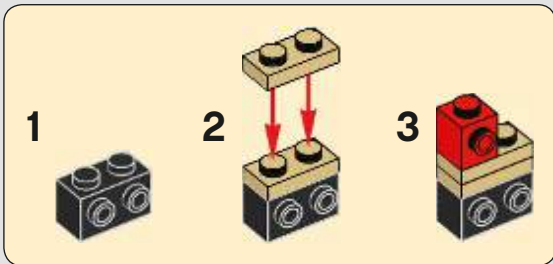

261

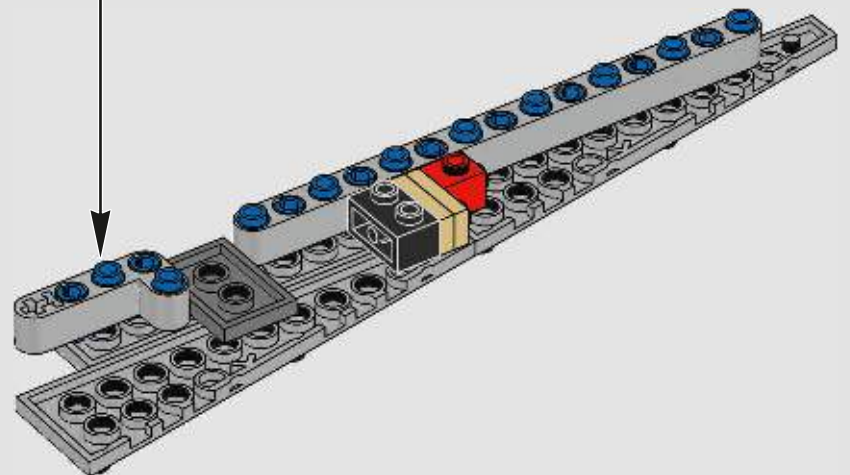

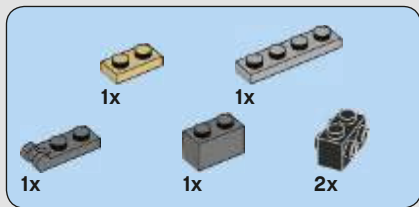

262

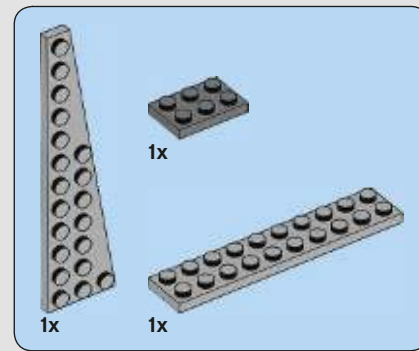
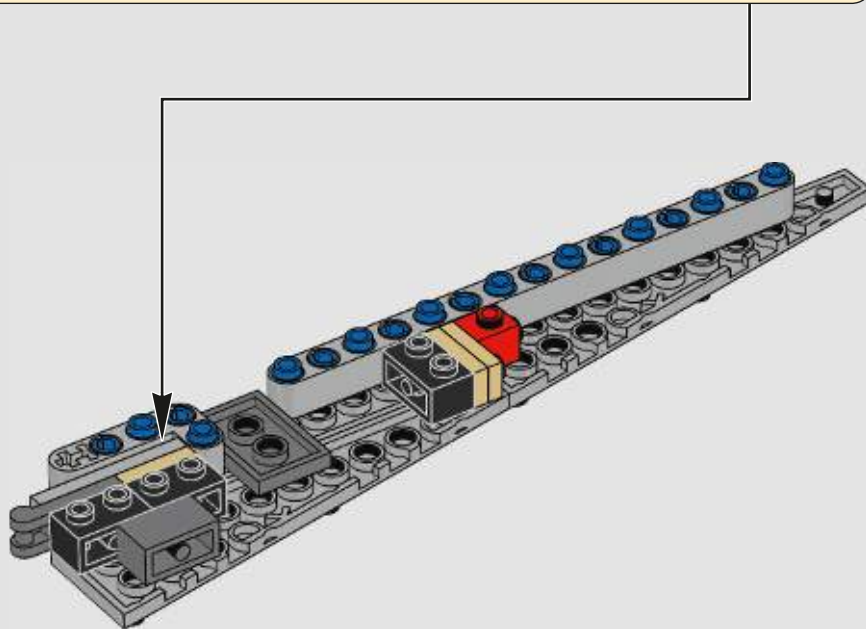
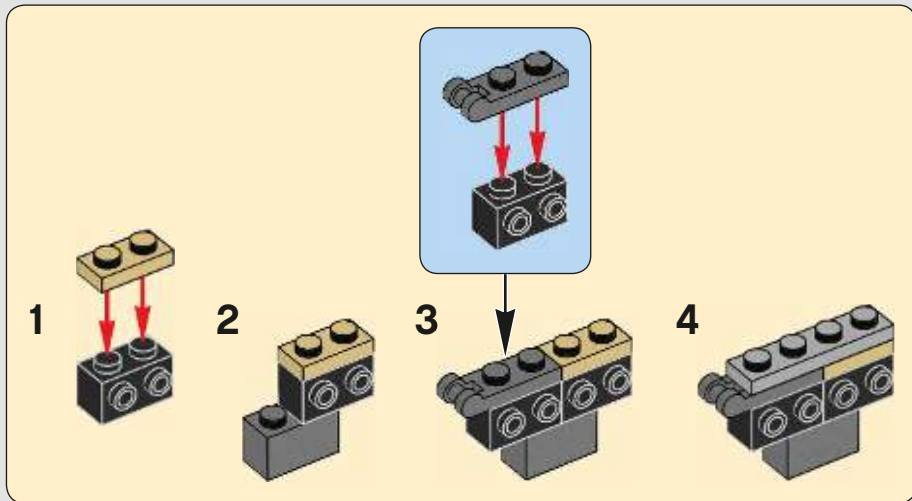

263

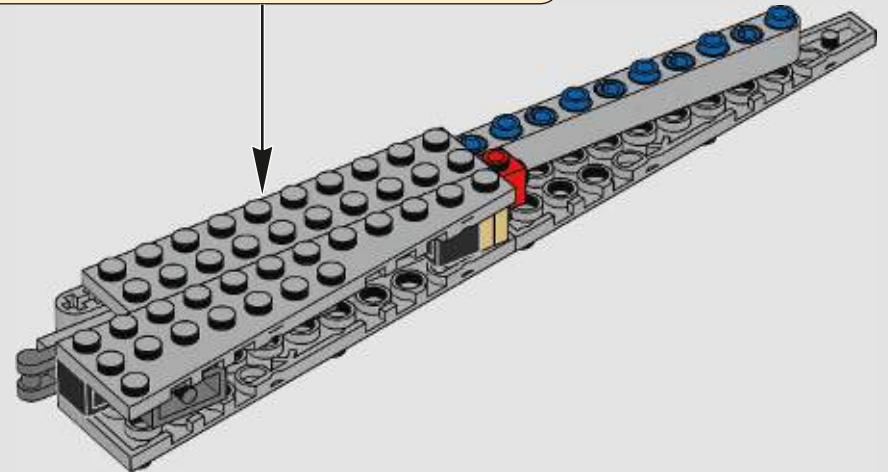
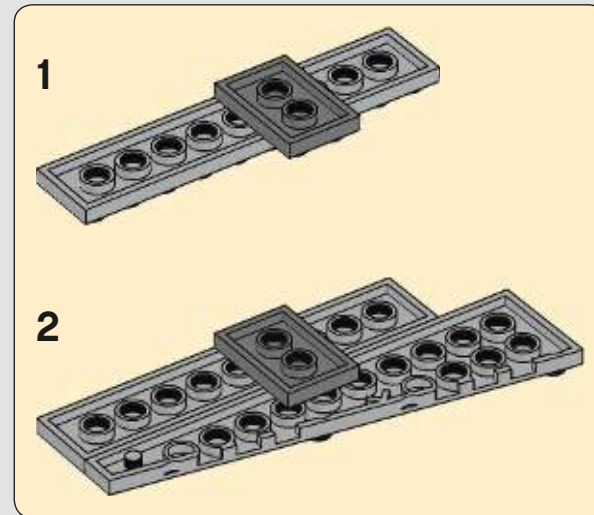

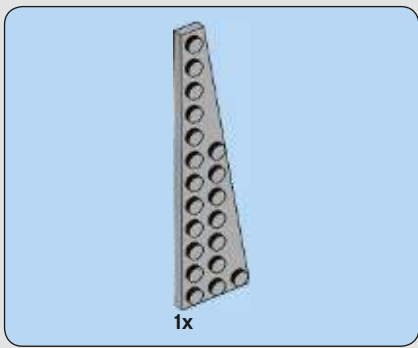

264

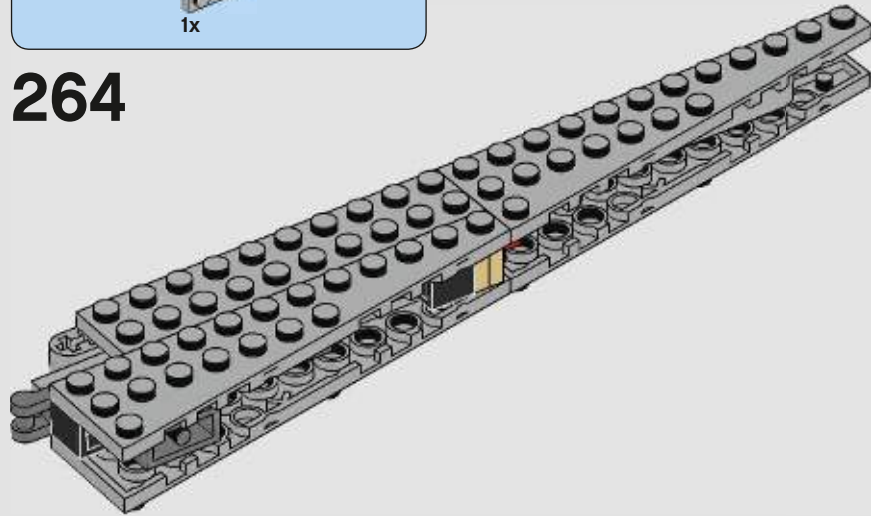

265

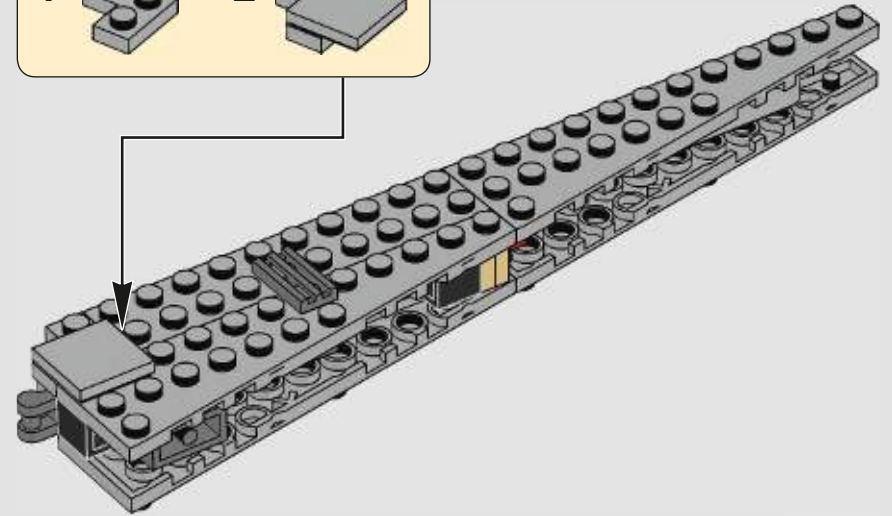
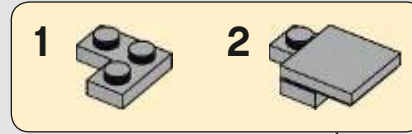

266

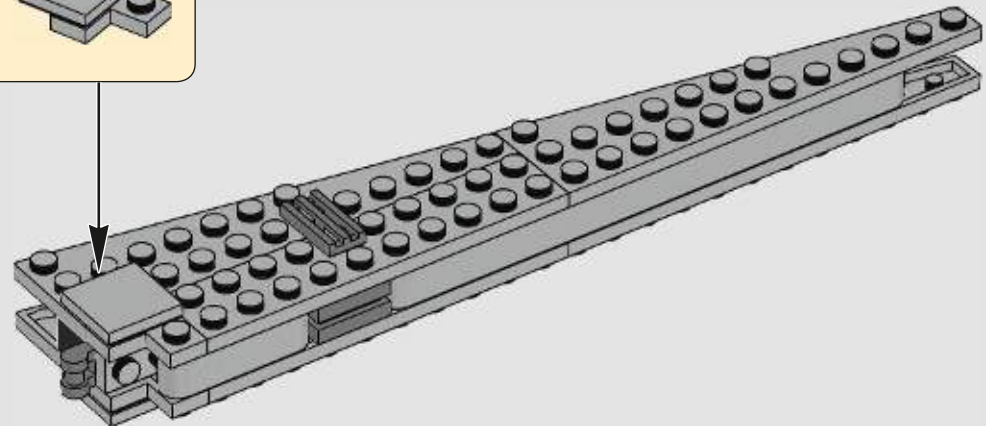
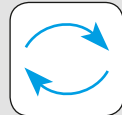
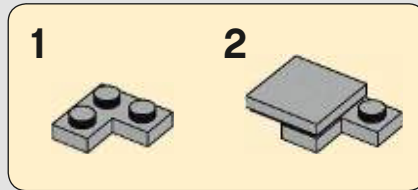

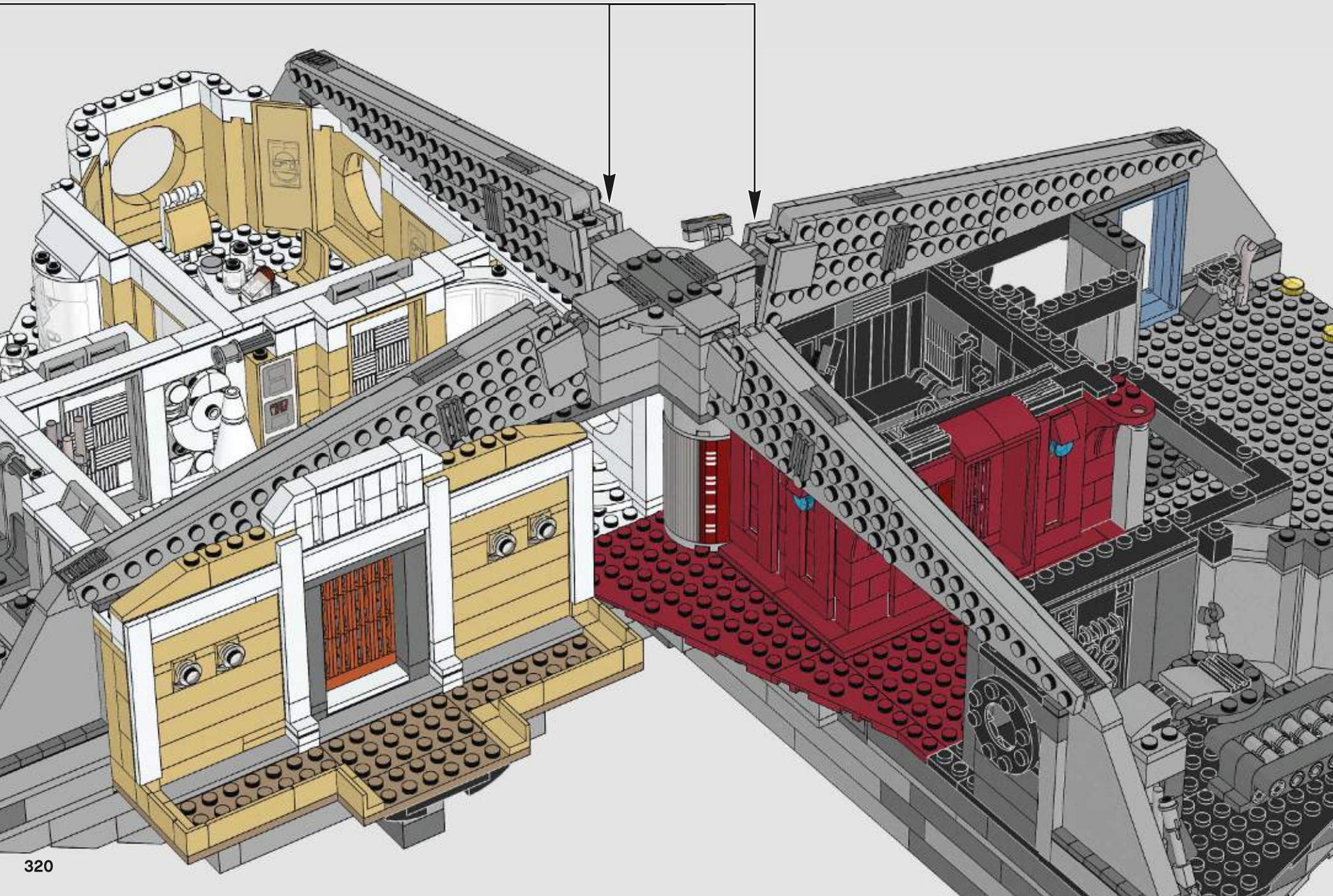

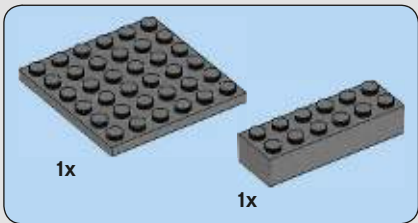
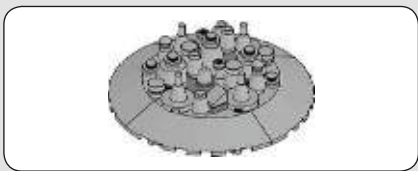

268

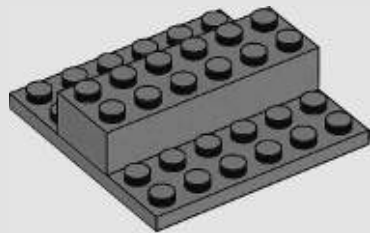

269

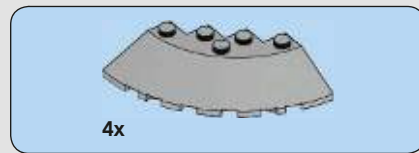
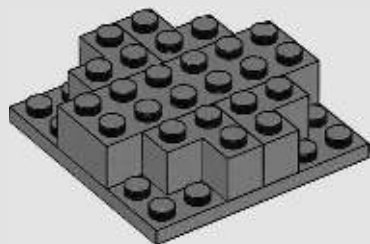

270

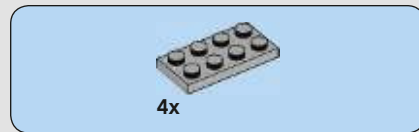
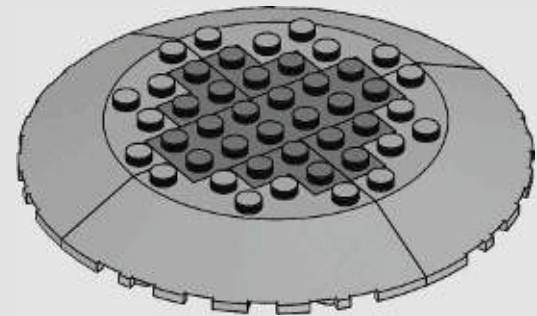

271

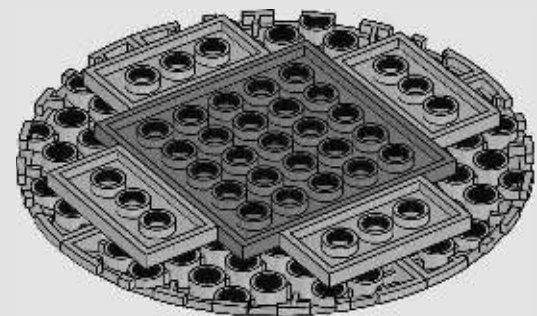
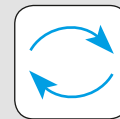



4x

272

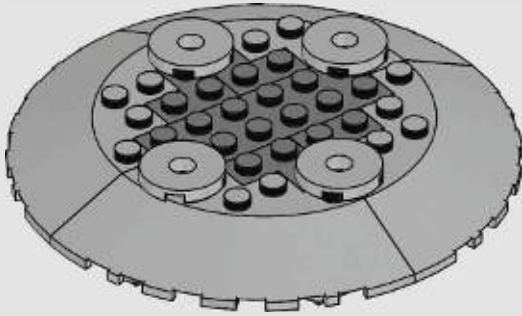

273

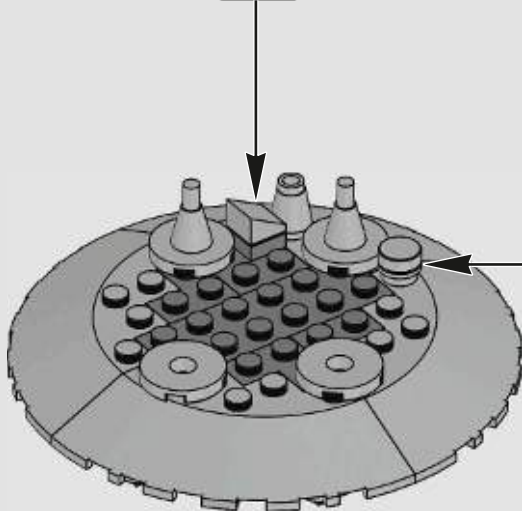
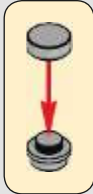
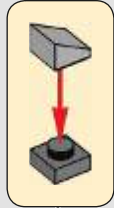

274

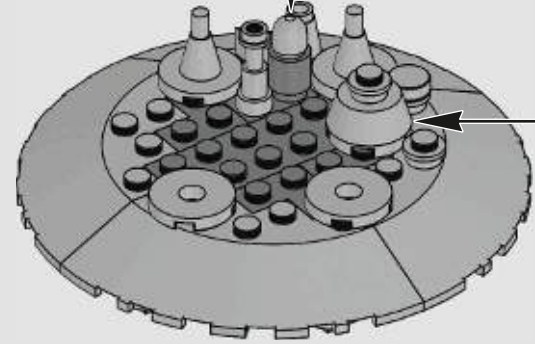
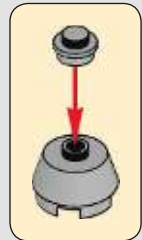

275

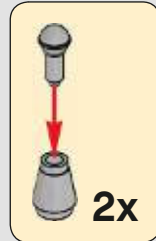

2x

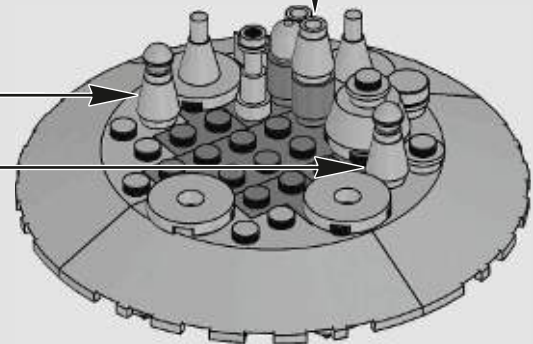

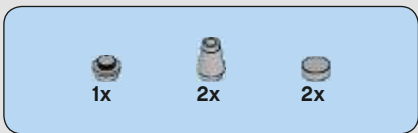

276

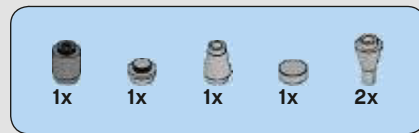
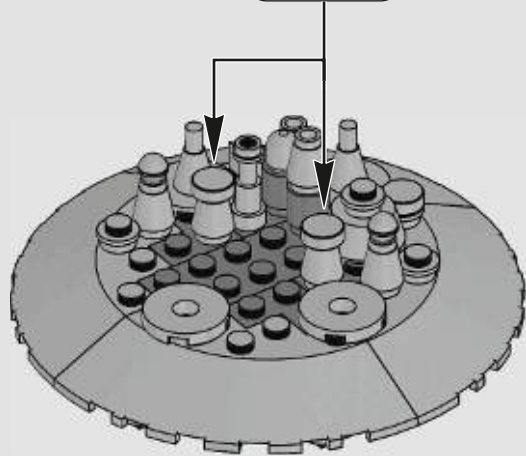
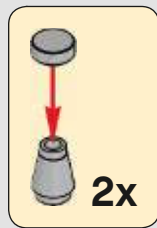

278

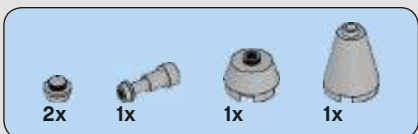
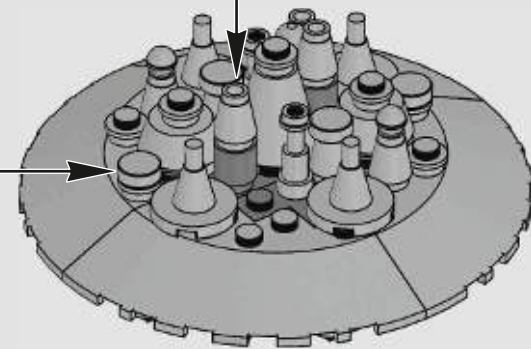
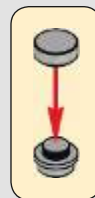

277

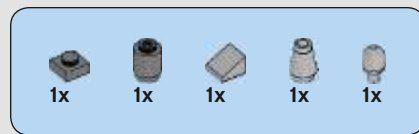
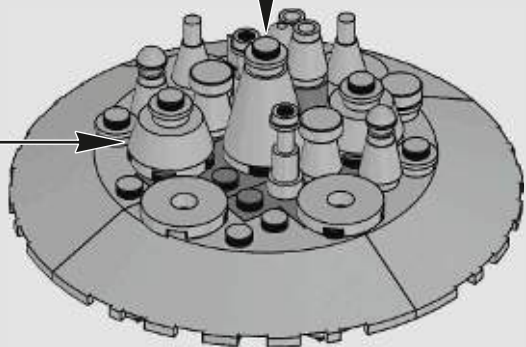
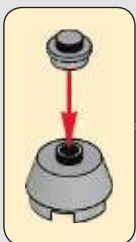
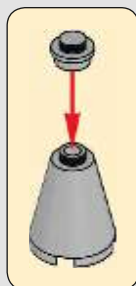

279

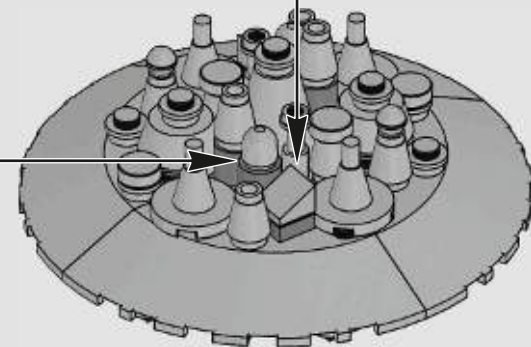
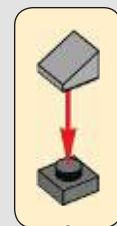

280

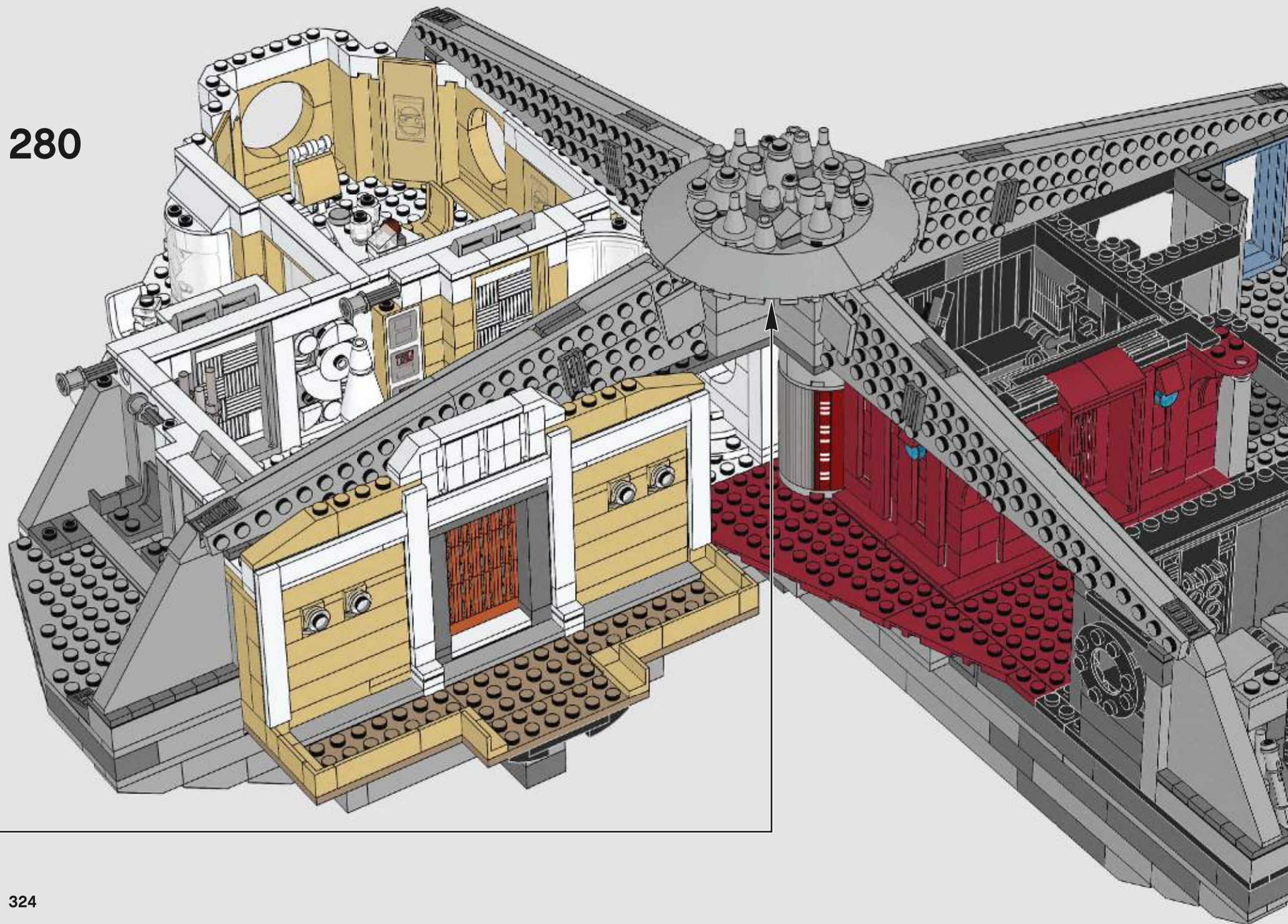

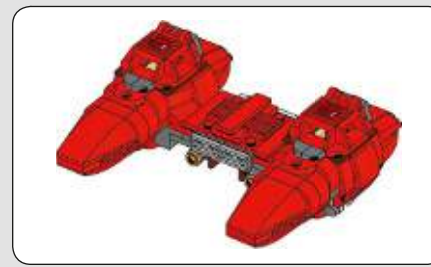
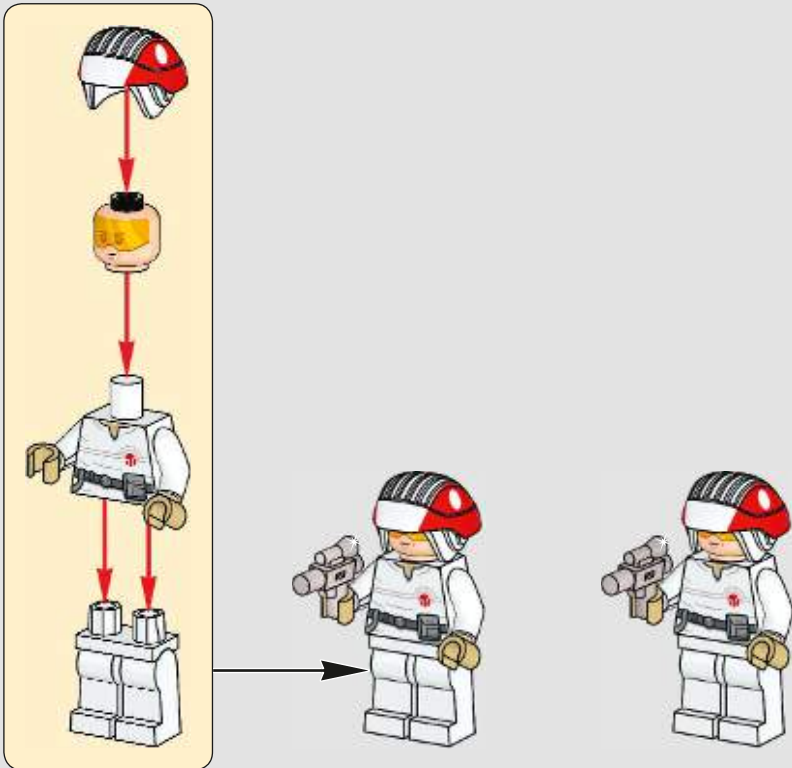
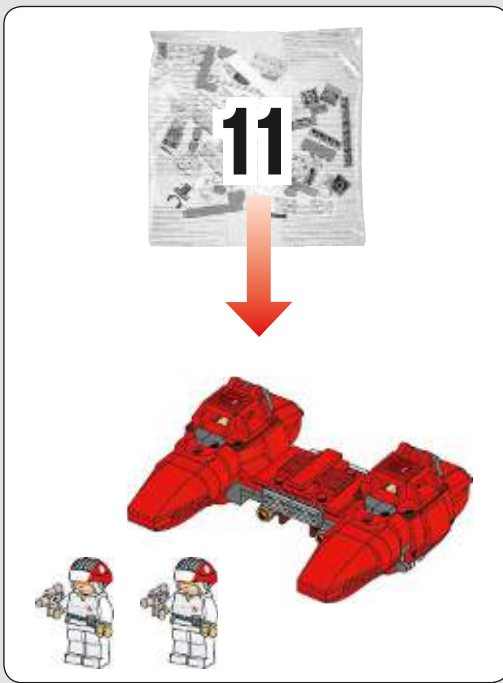

1

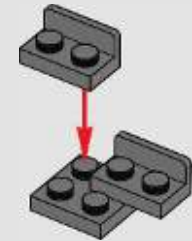

2

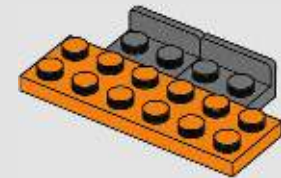

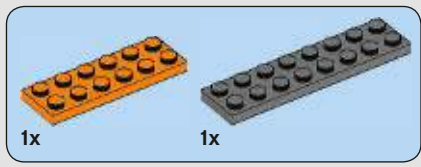

3

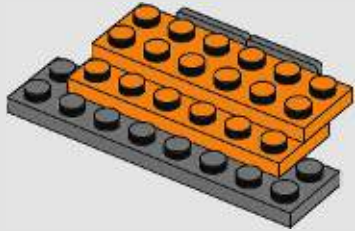

4

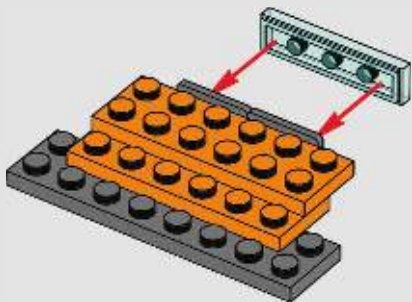

5

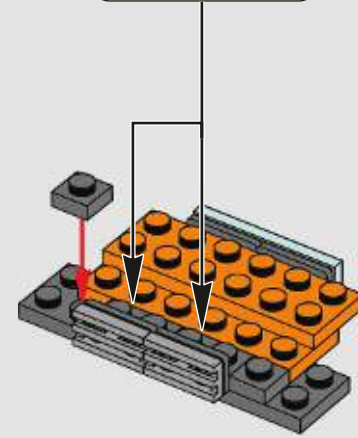
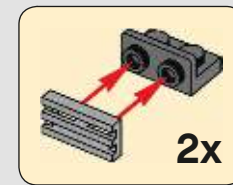

6

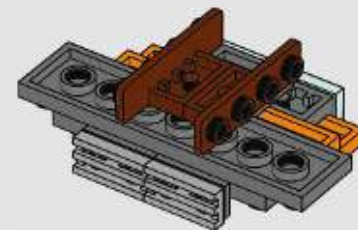
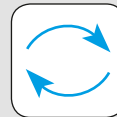

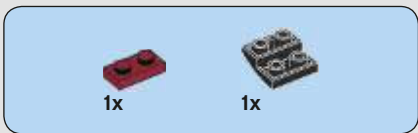

7

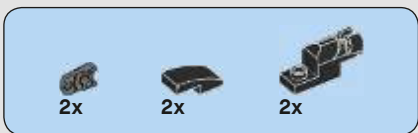
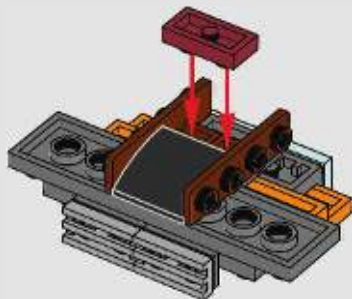

8

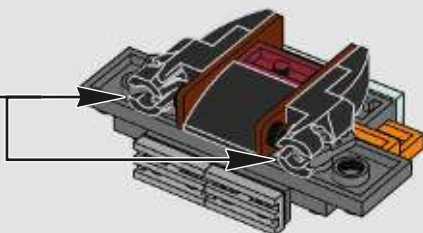
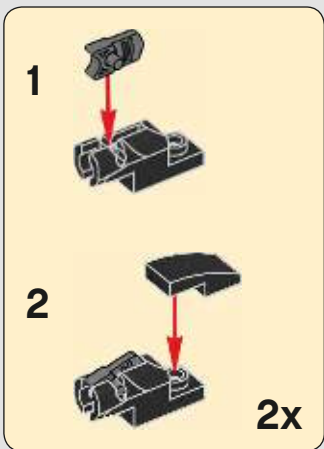

9

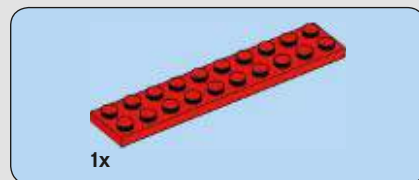
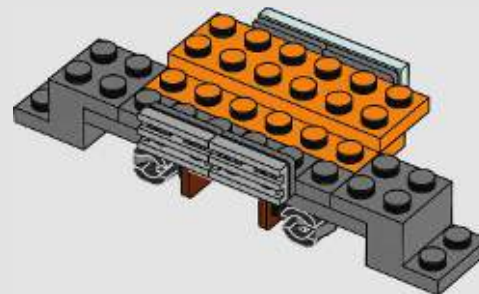
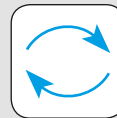

10

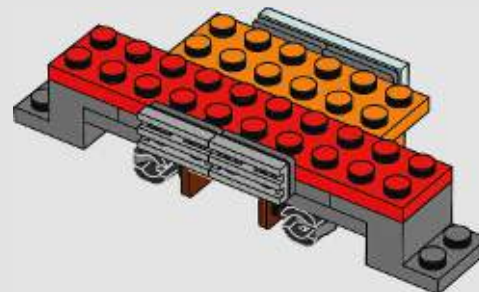

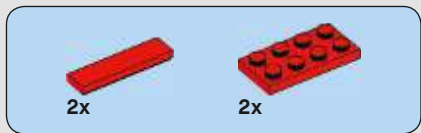

11

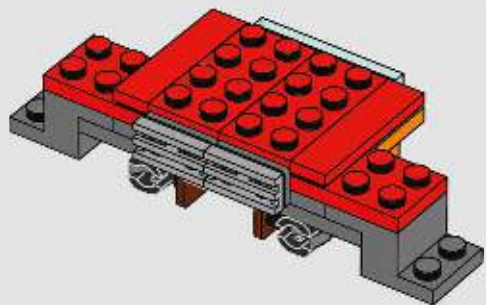

12

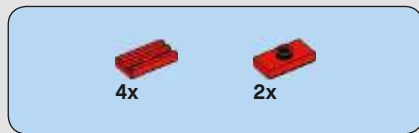
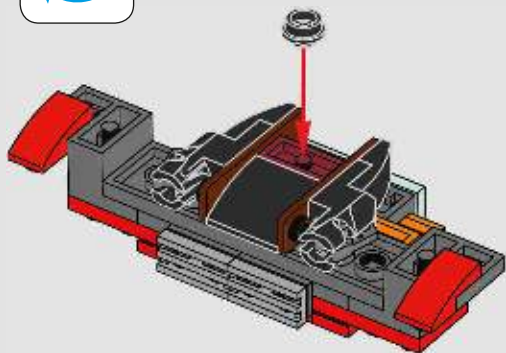
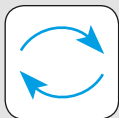

13

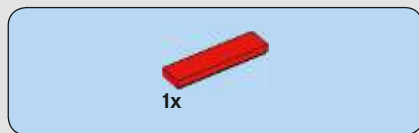
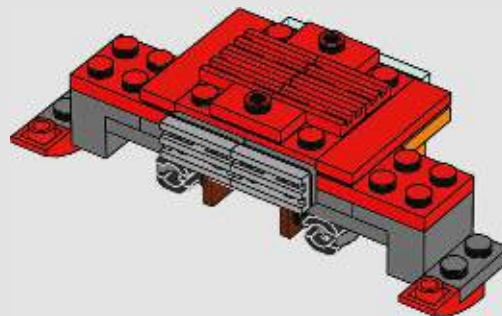
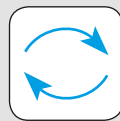

14

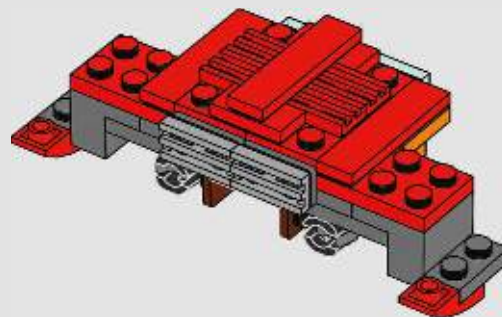



15

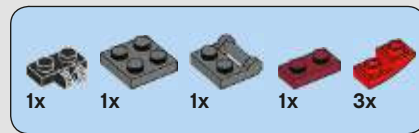
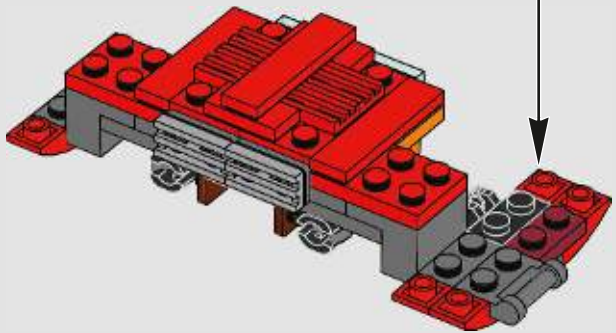
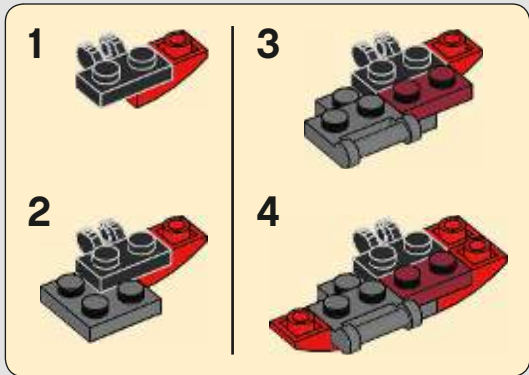

16

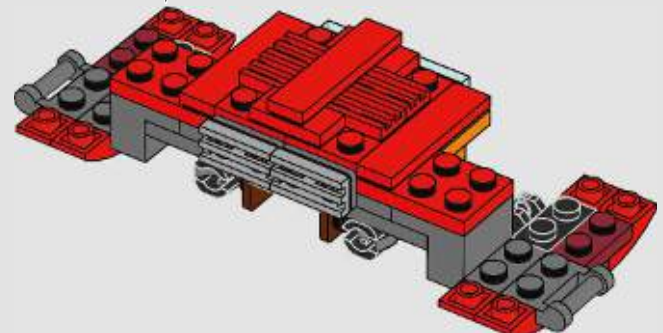
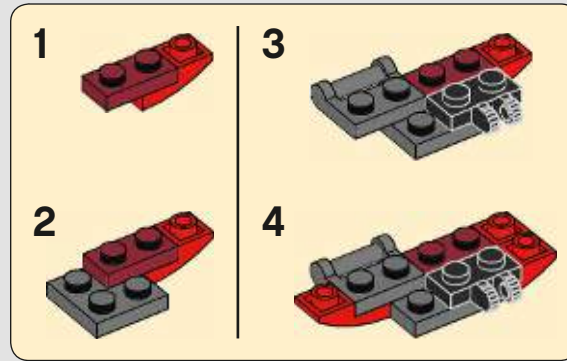



17

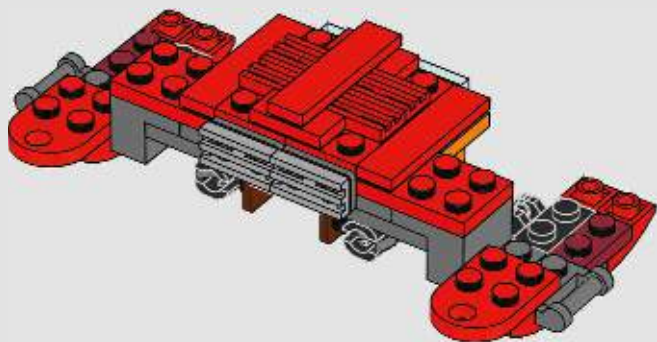

18



19



20



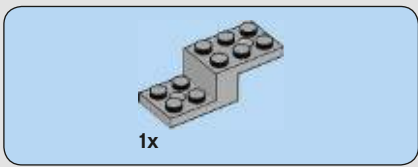

21

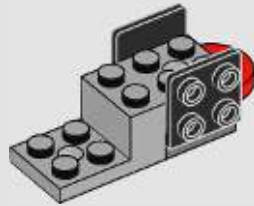

22

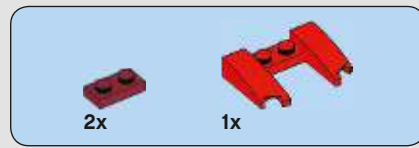
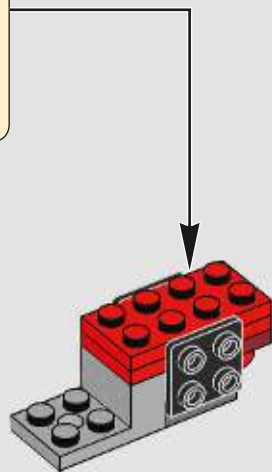
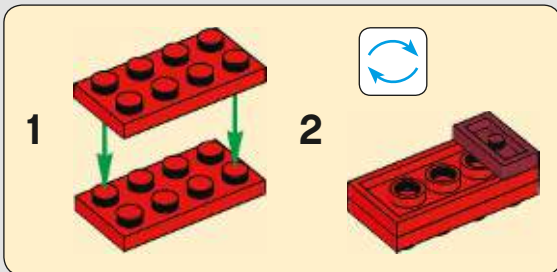

23



24

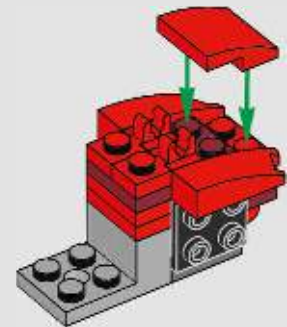

2x
331

25

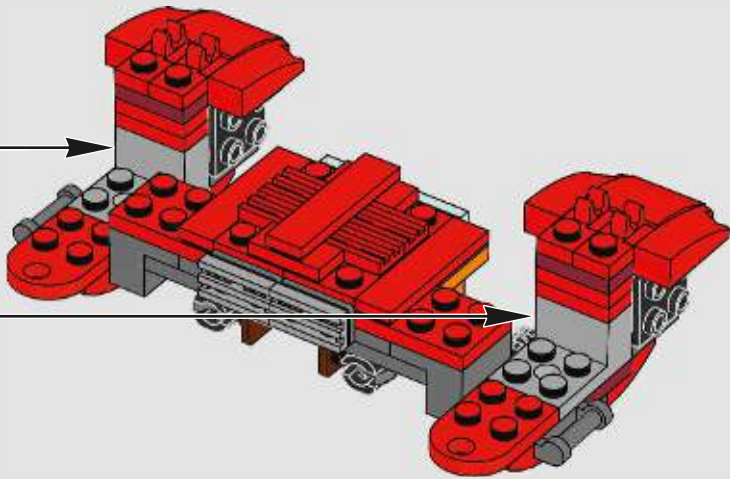

2x



1x



1x

26

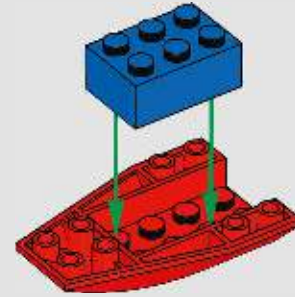

2x

27

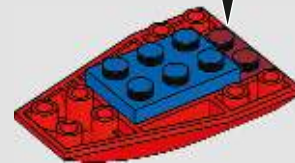
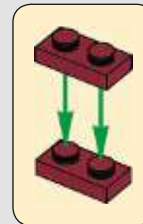

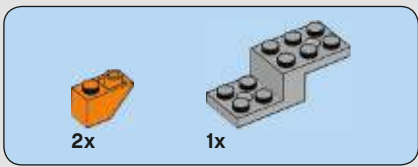

28

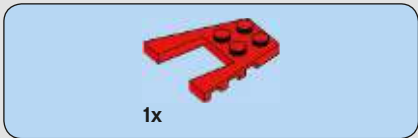
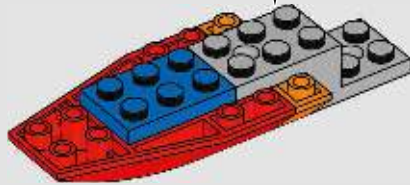
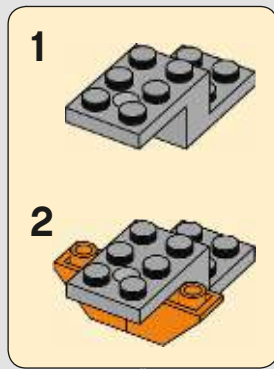

29



30

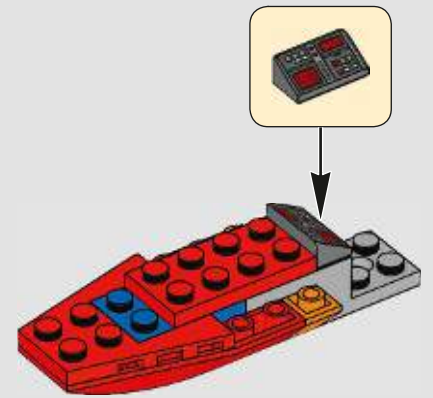

31

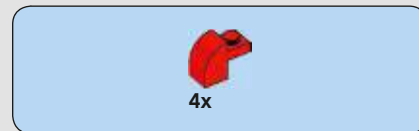
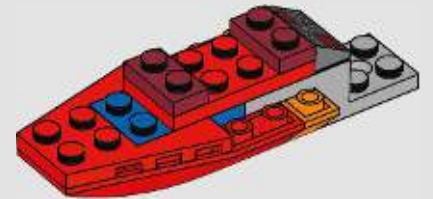

32

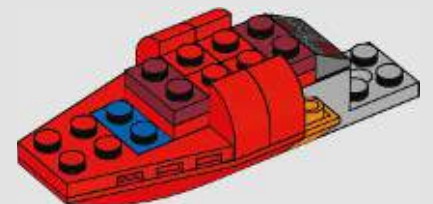

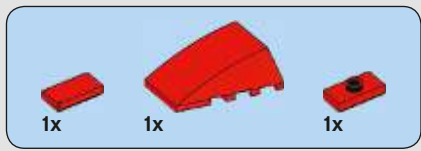

33

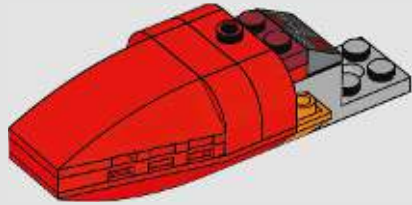

2x

34

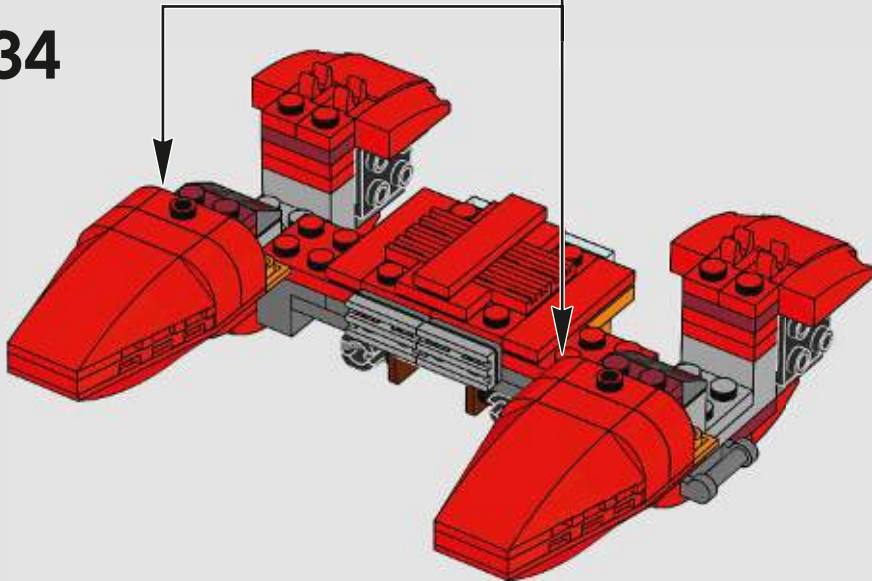

35

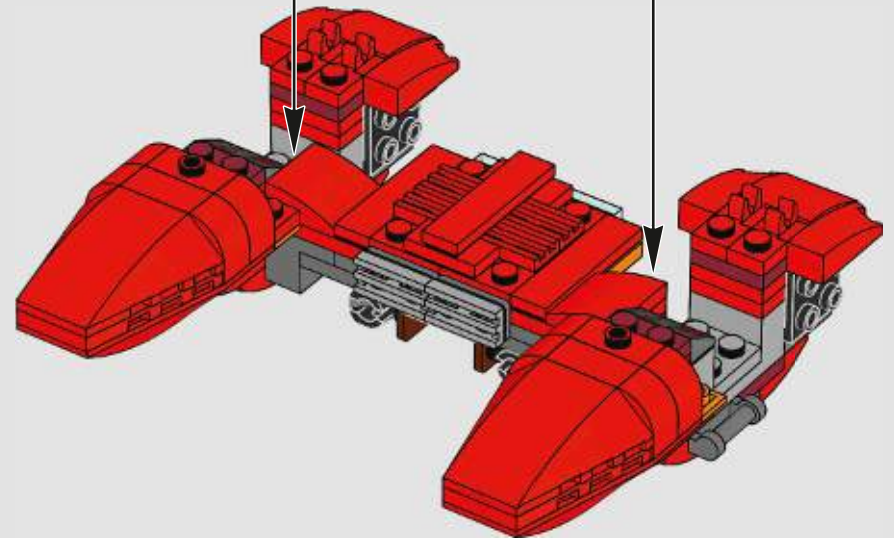
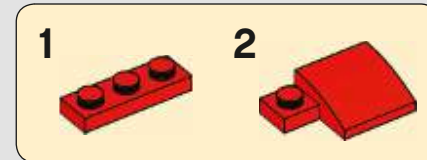
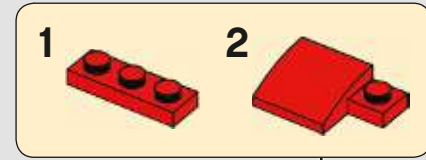



36

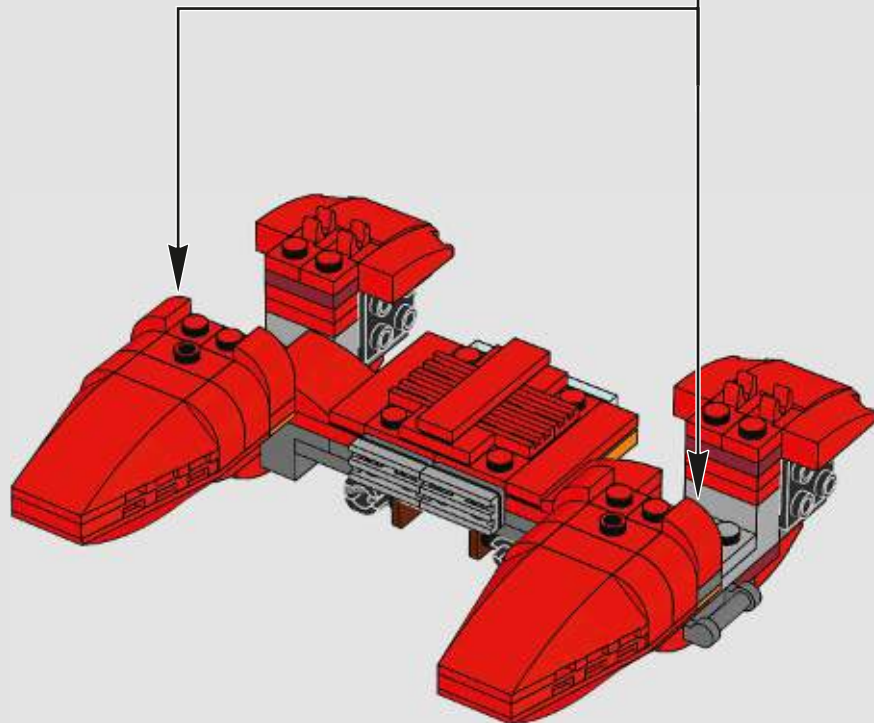
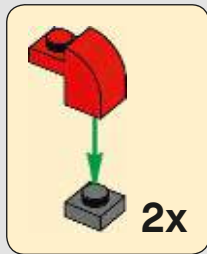

37

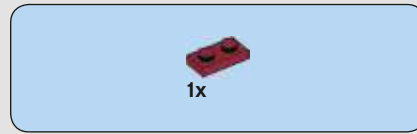
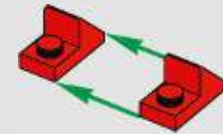

38



39



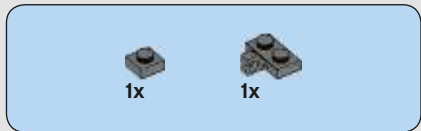

40

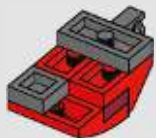

41

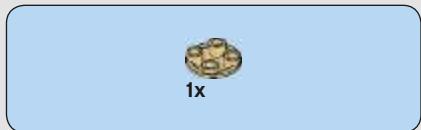

42



43

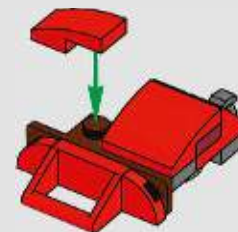
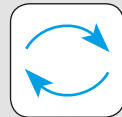

44

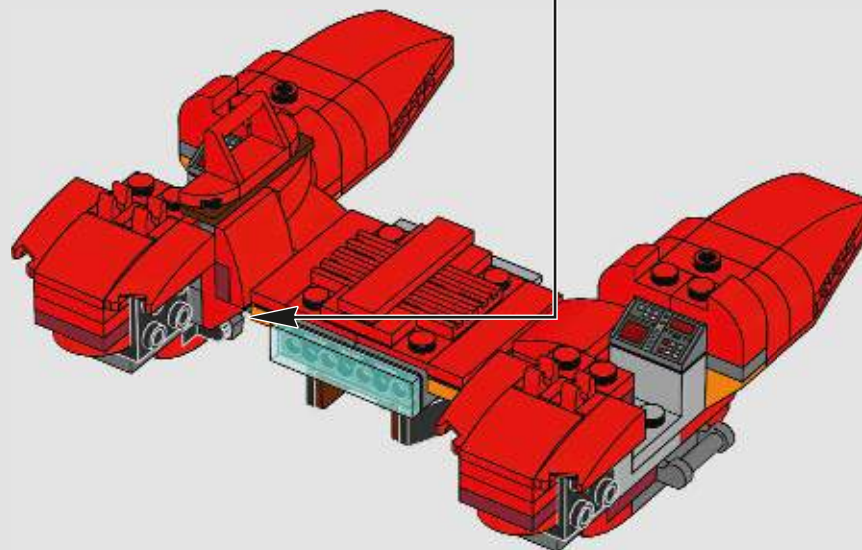
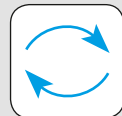



45

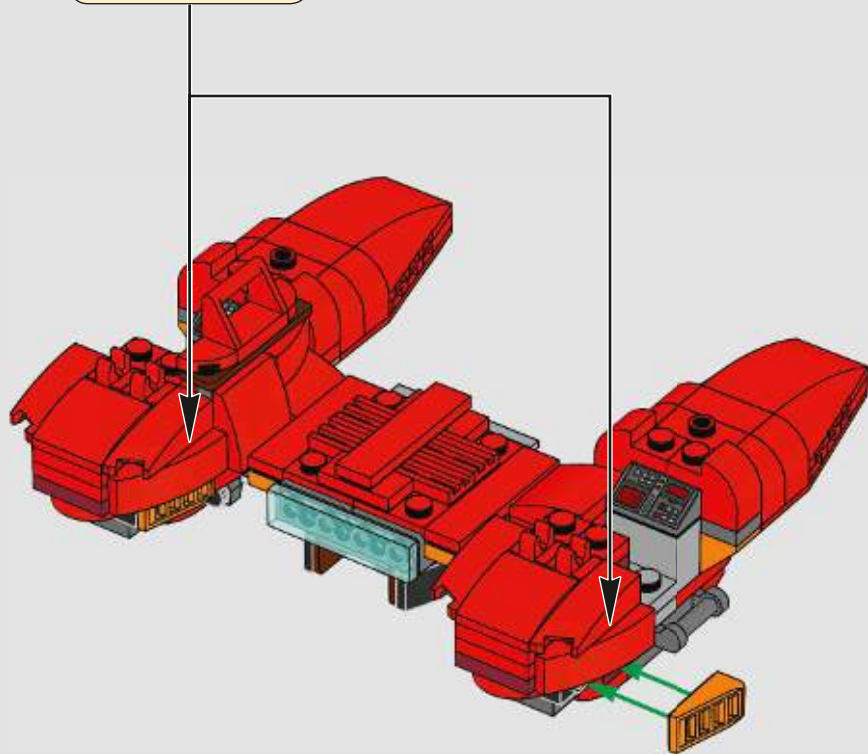
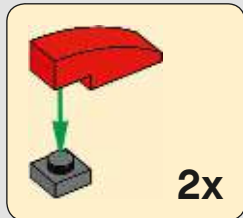

46

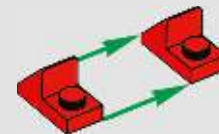

47



48



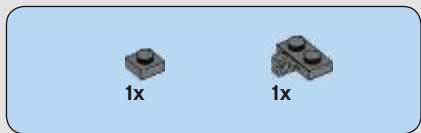

49

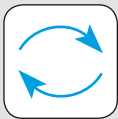

50

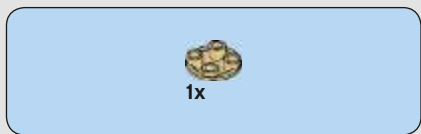

51



52

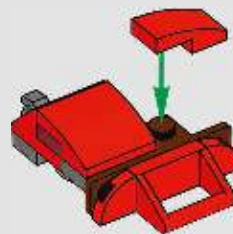
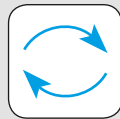

53

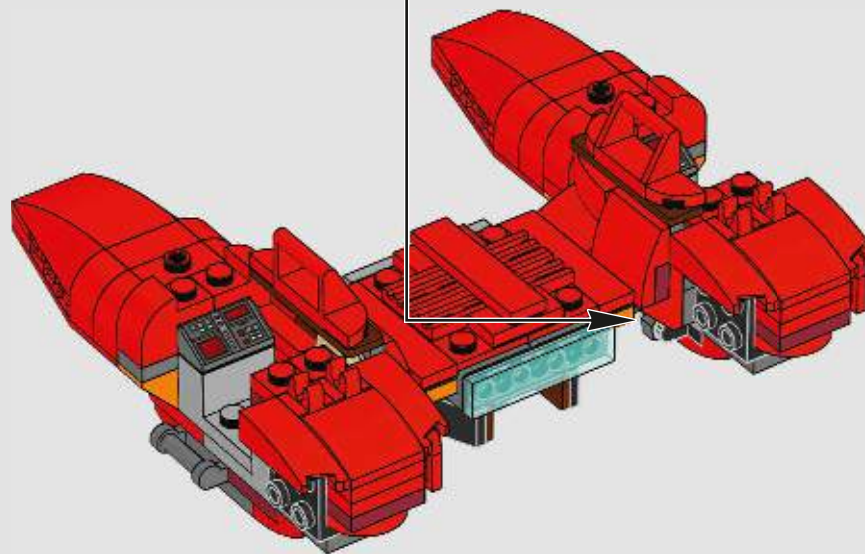



54

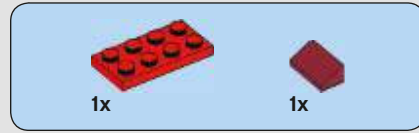
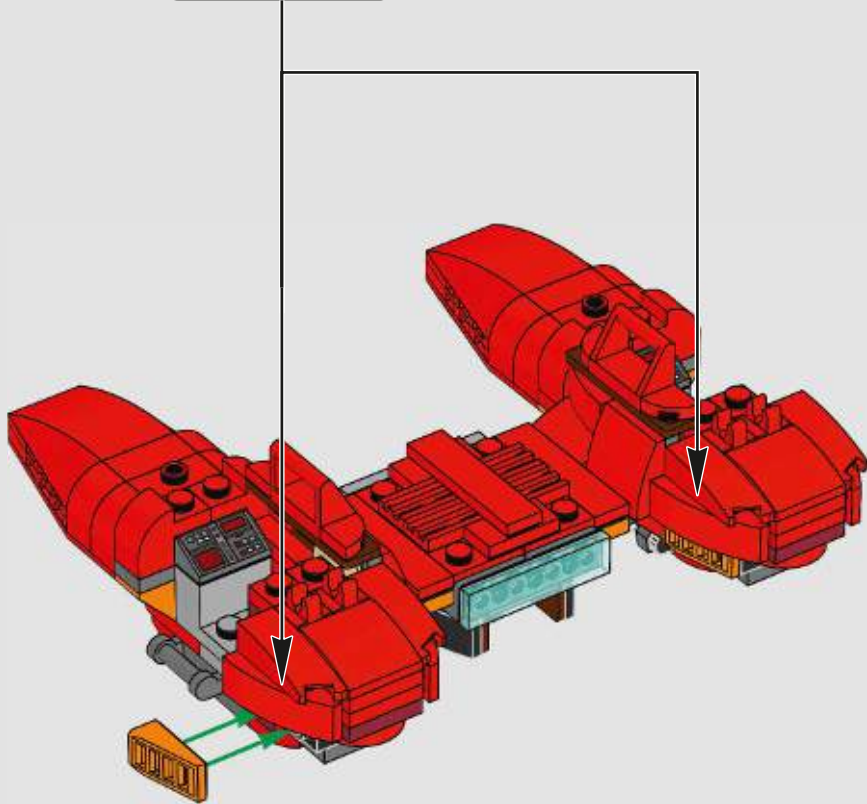
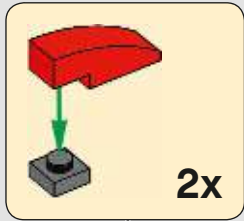

55

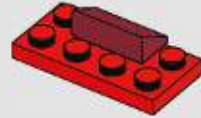

56

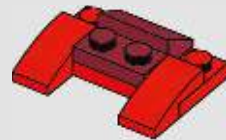

57

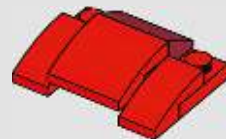



58

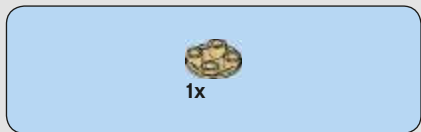
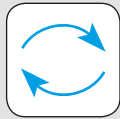

59



60

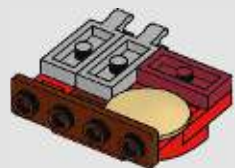

61

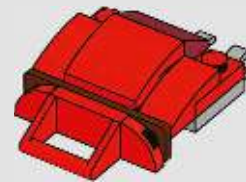
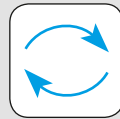

62

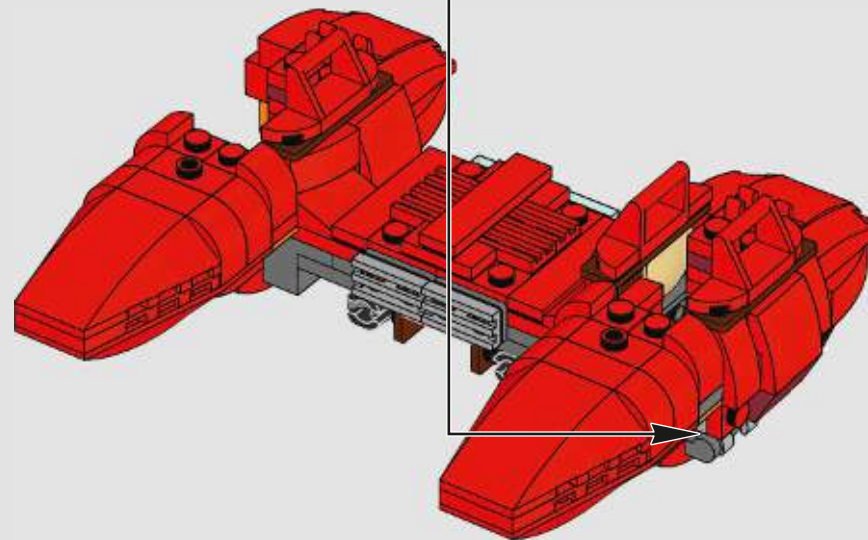



63

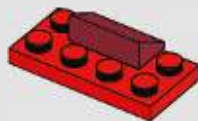

64

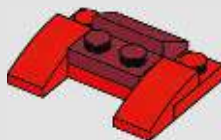

65

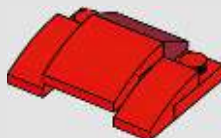

66

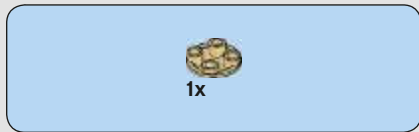
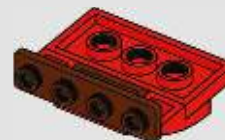
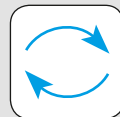

67



68

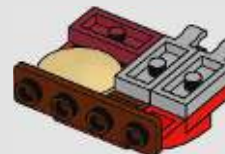



69

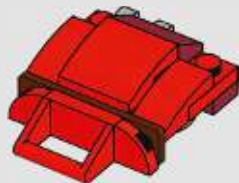

70

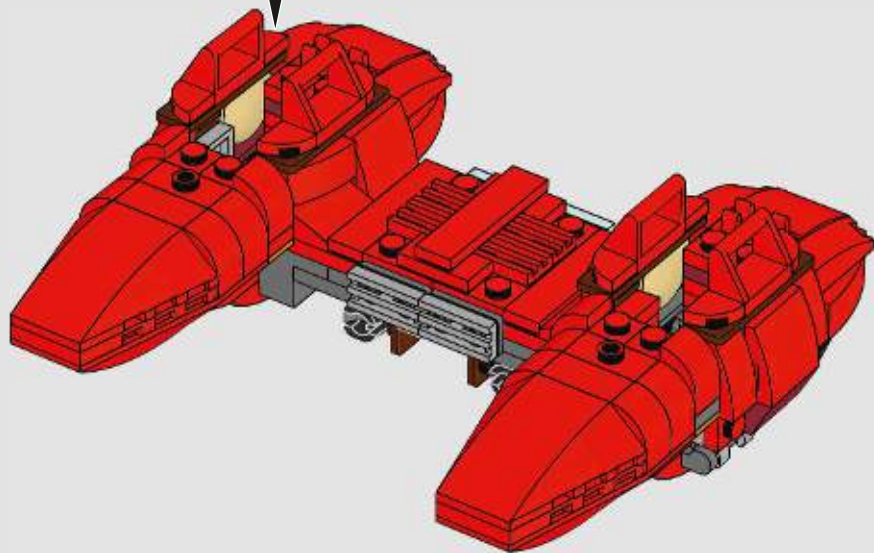

71

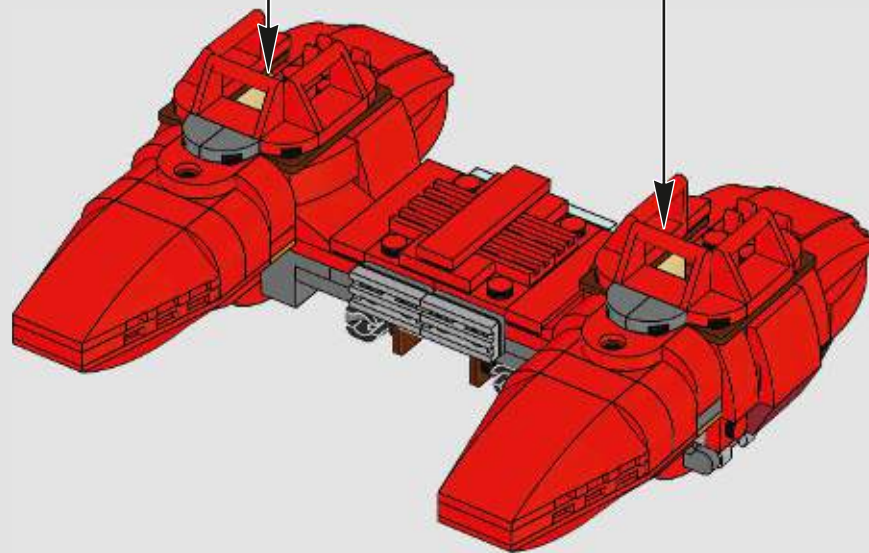
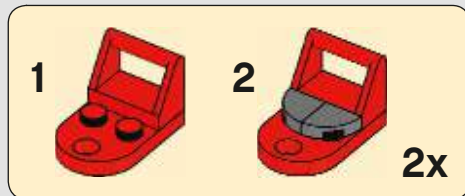



72

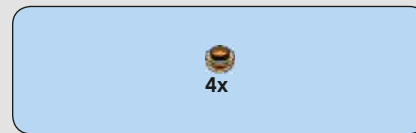
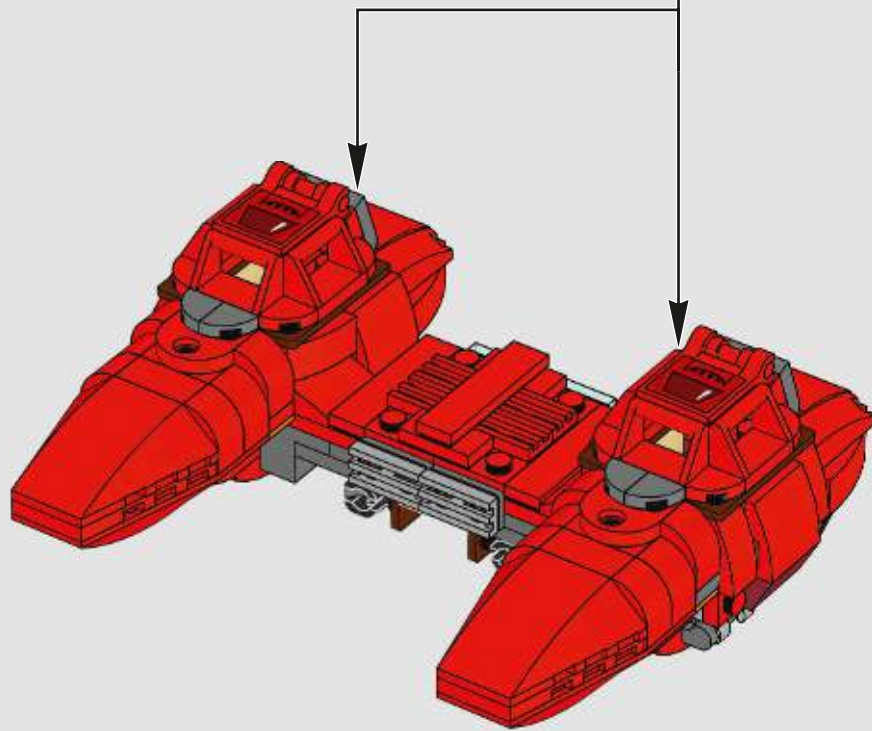

73

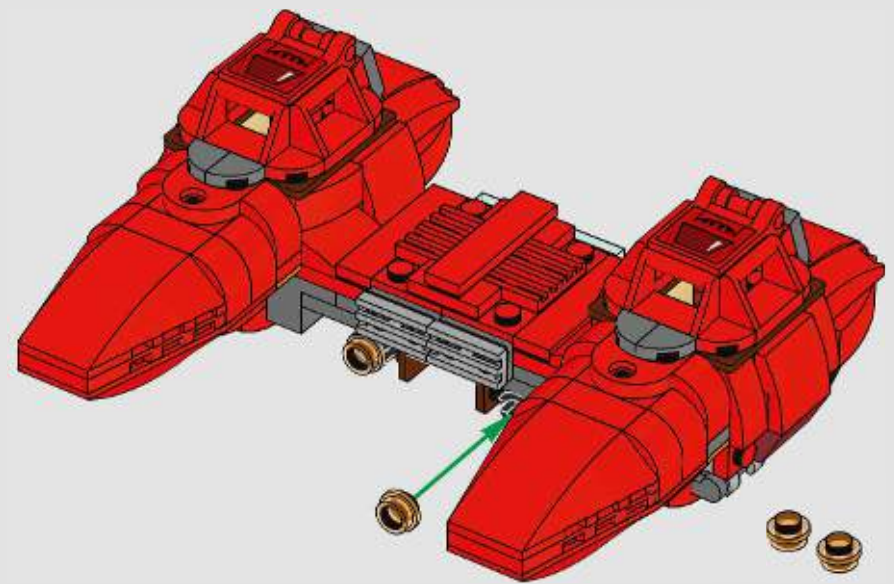

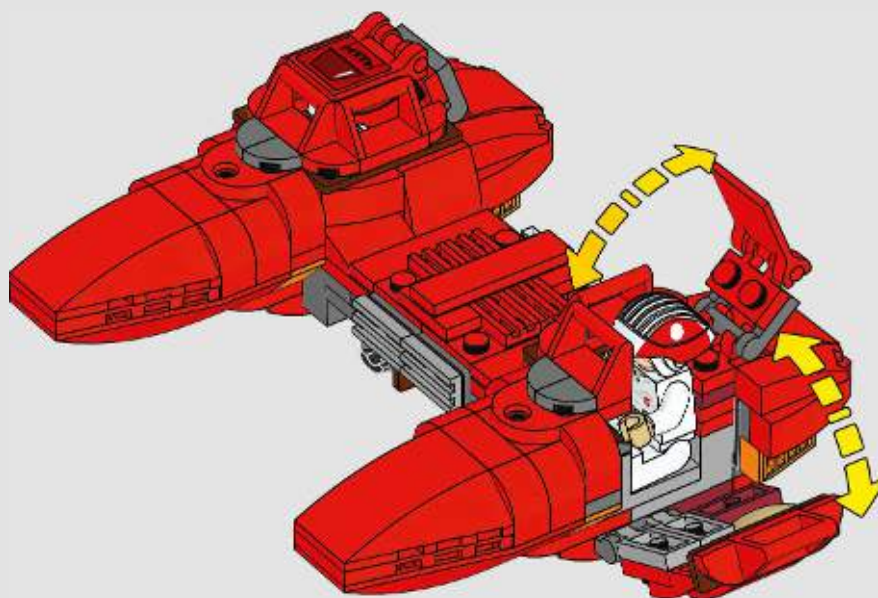
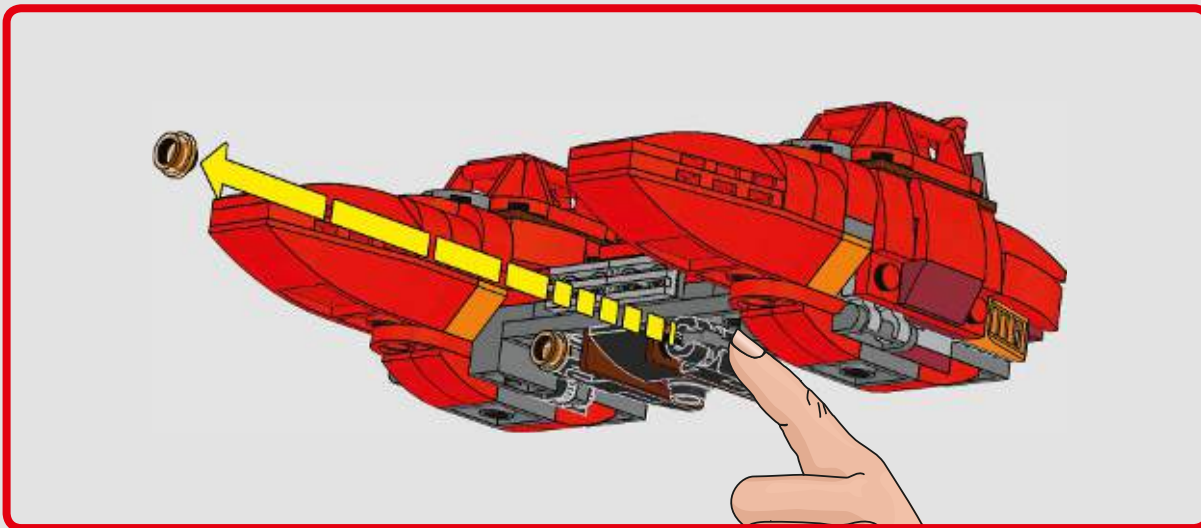

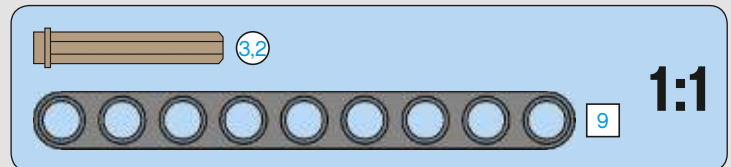
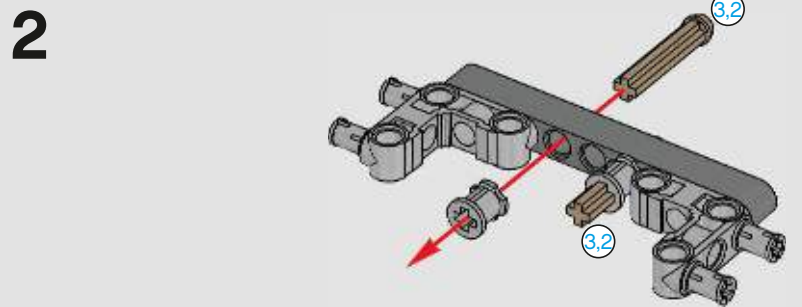
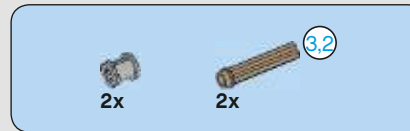
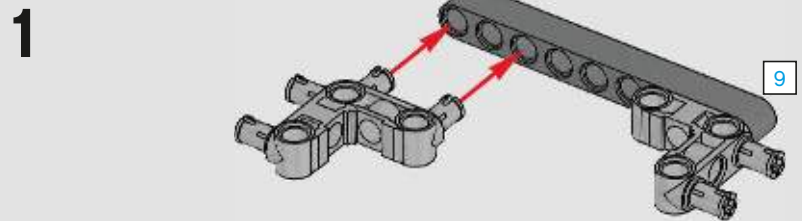
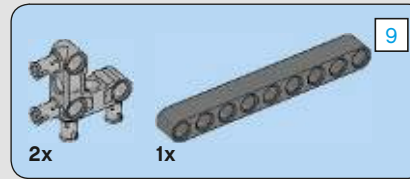
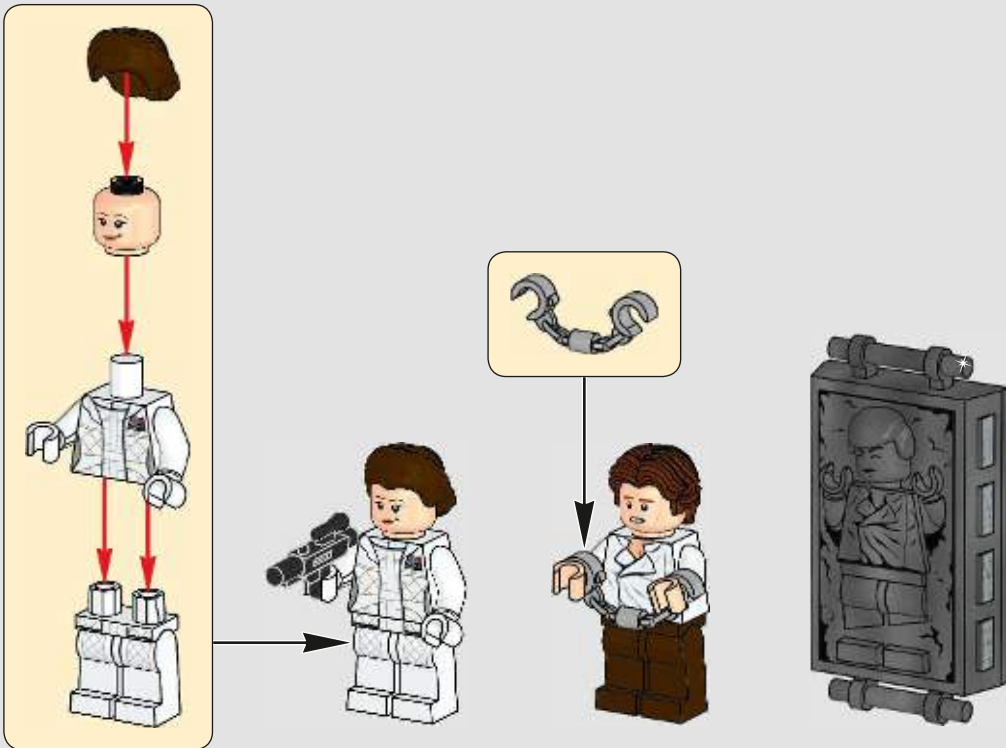
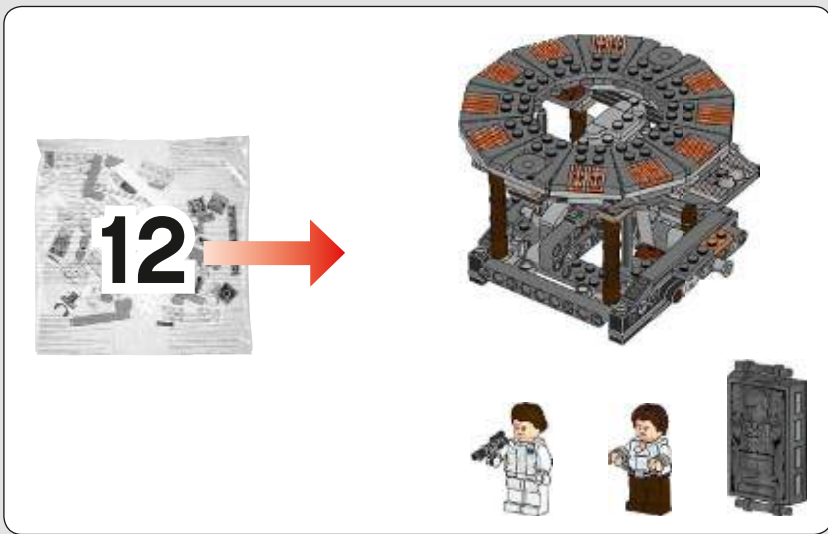

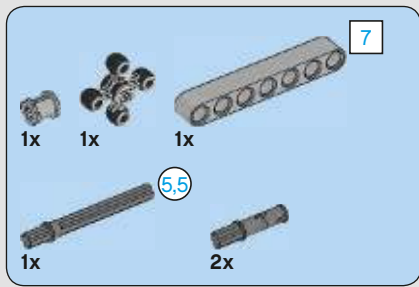

3

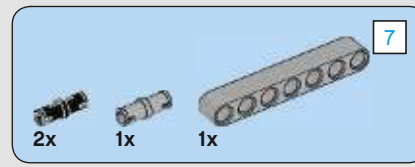
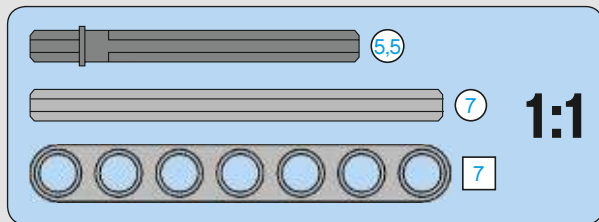
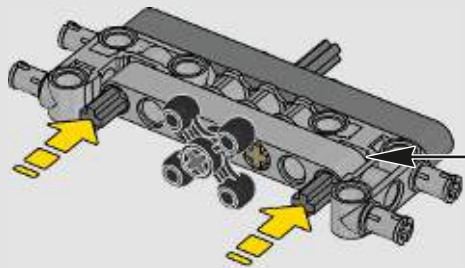
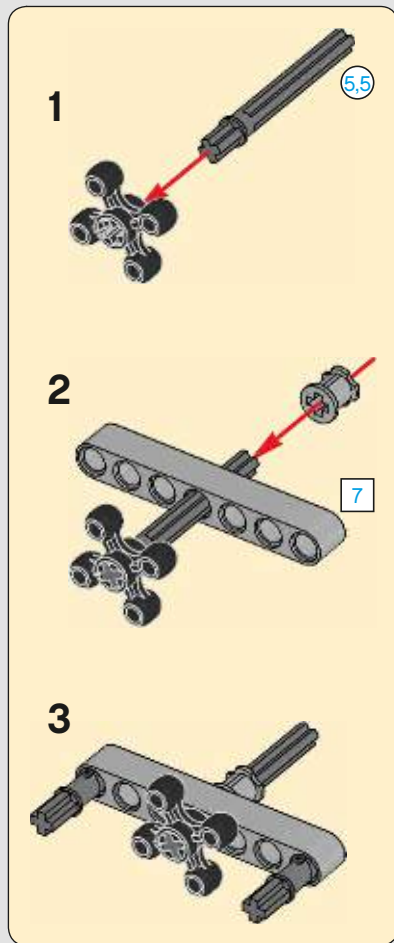

4

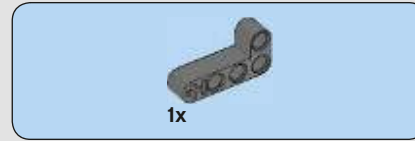
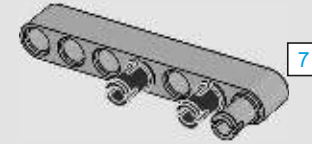

5

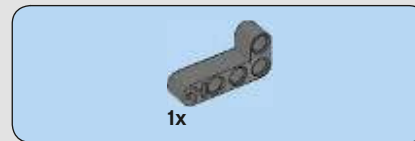
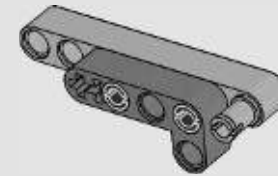

6

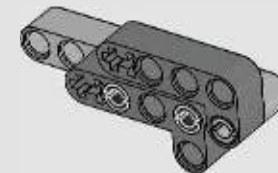



7

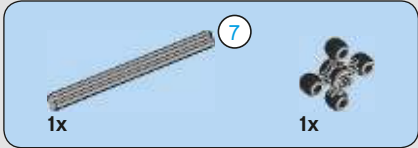
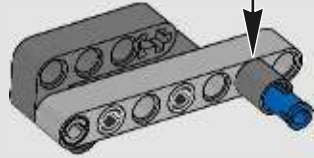
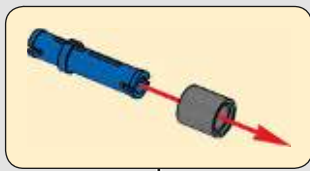

8

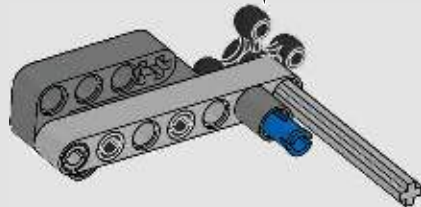
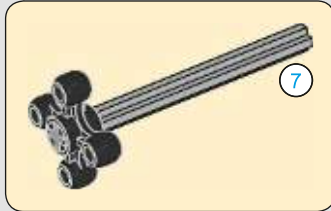

9

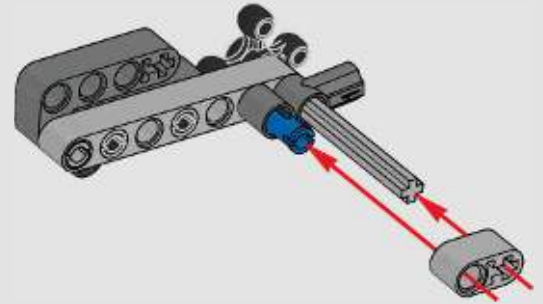

10

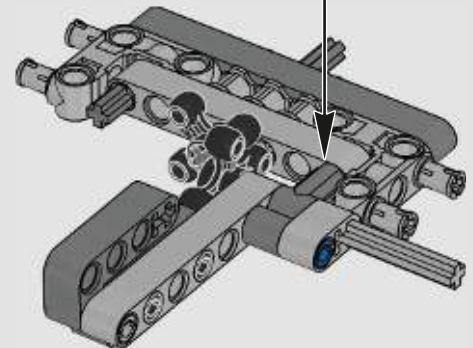

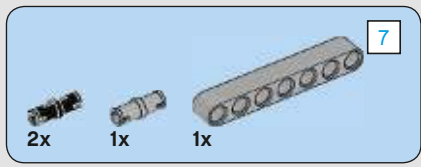

11

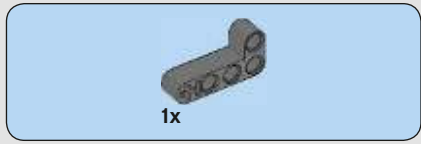
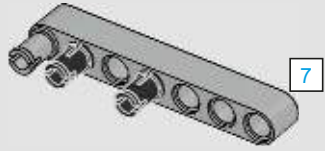

12

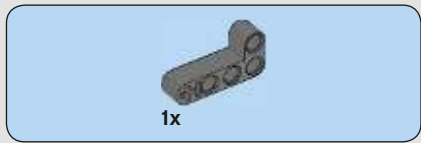
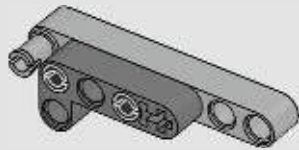

13

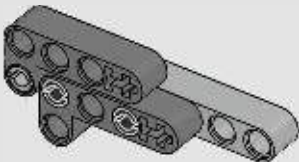

14

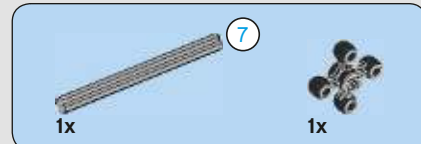
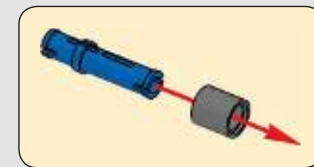
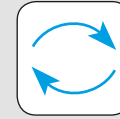

15

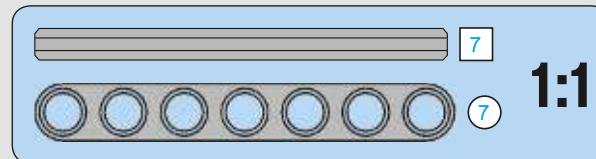
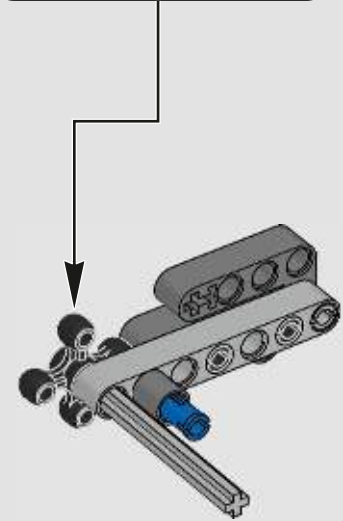
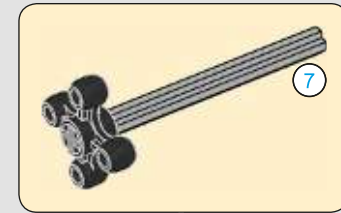

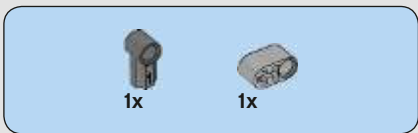

16

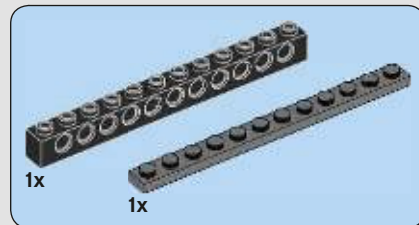
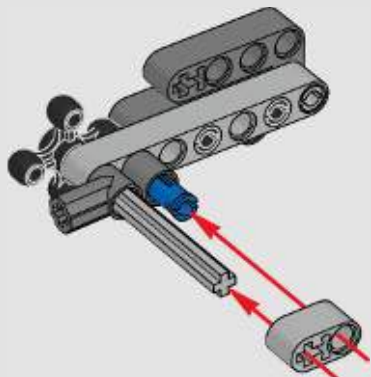

18

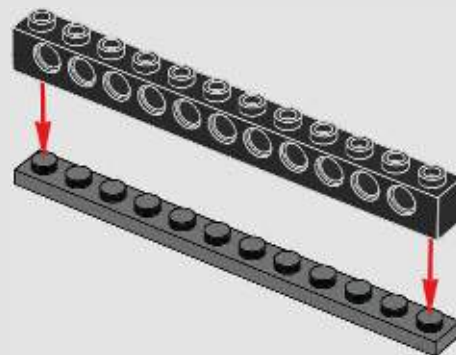

19

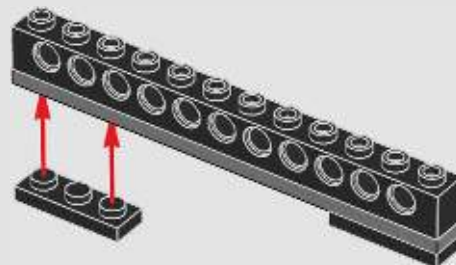

17

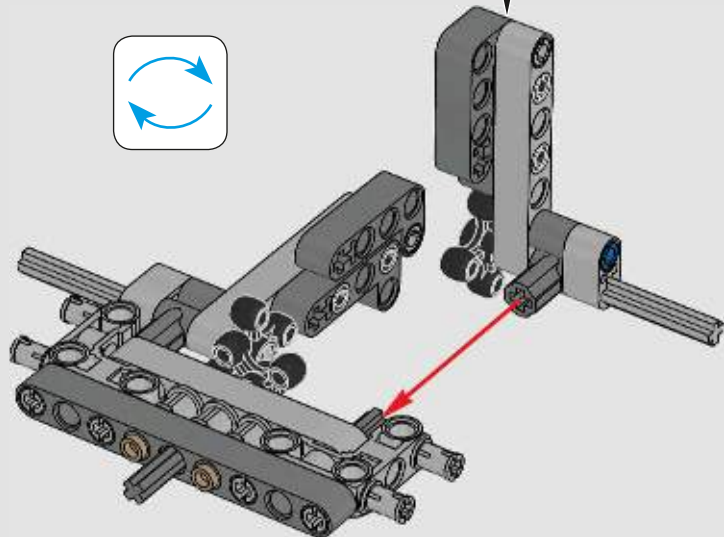
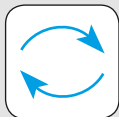

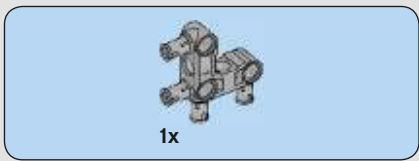

20

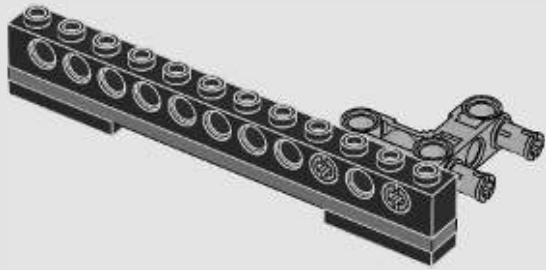

21

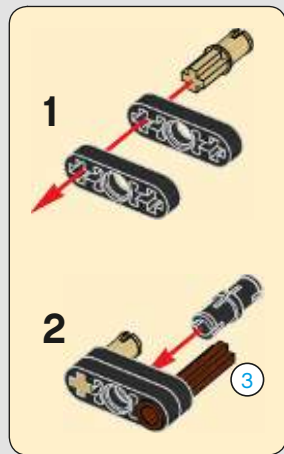
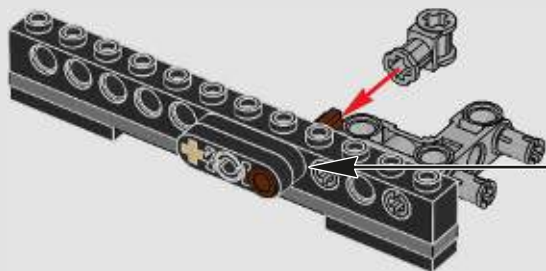

22

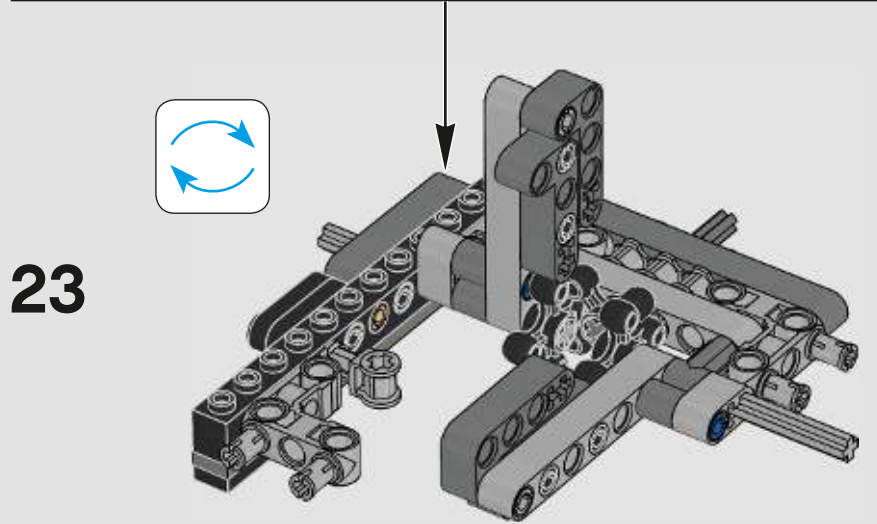
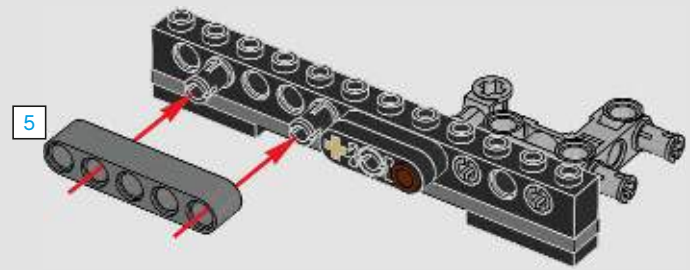

23

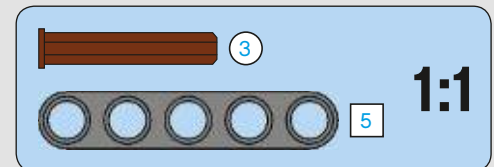

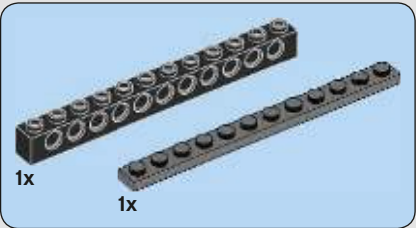

24

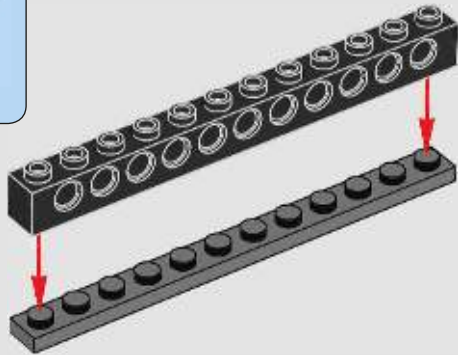

25

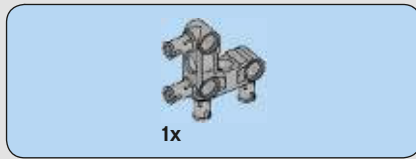
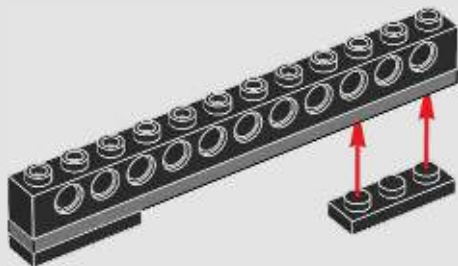

26

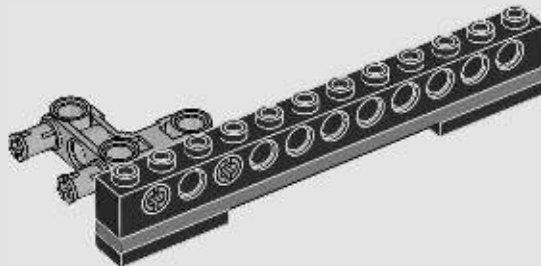

27

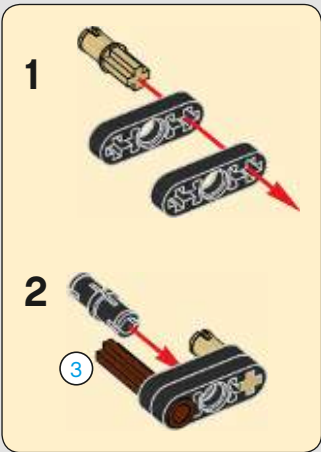
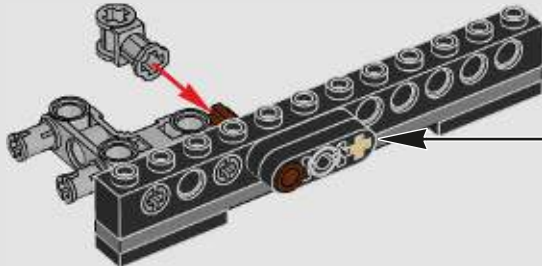

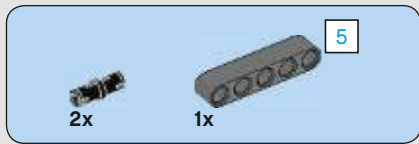

28

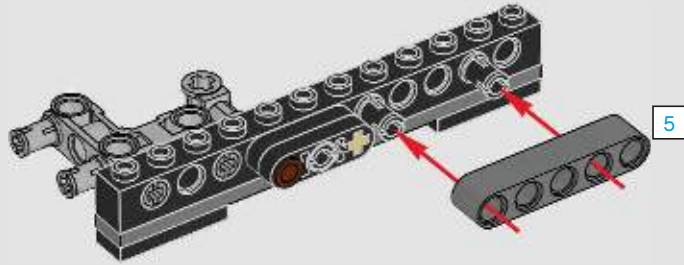

29

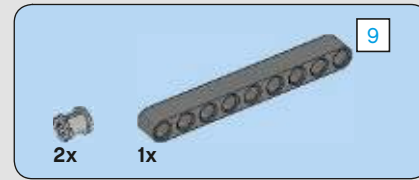
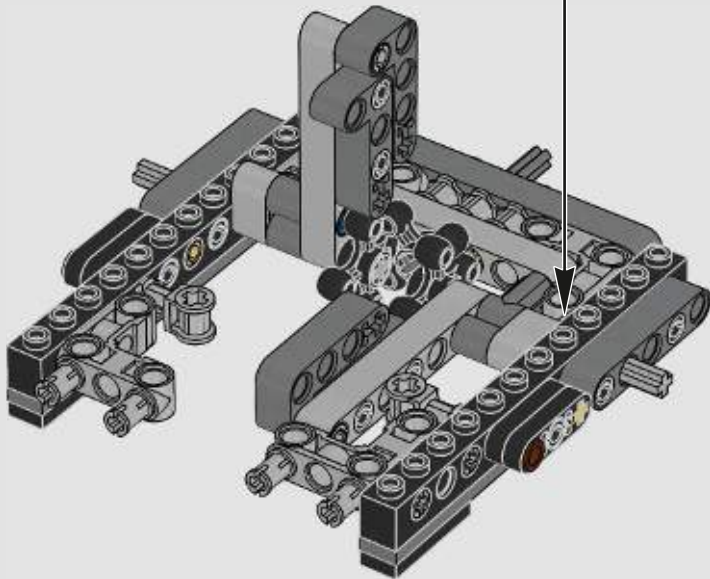

30

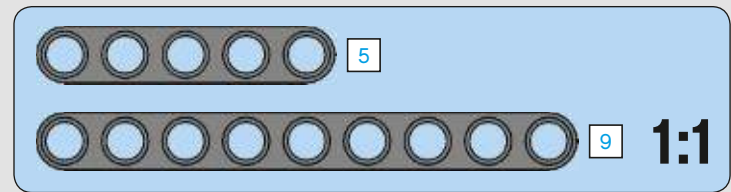
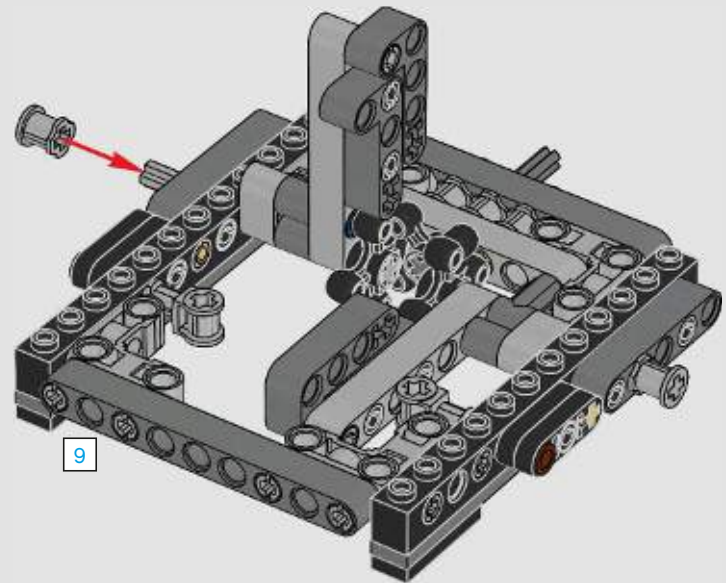

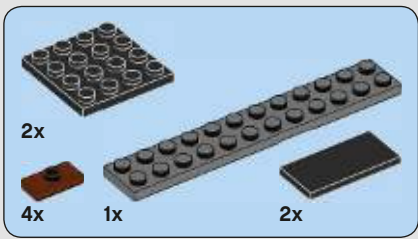

31

1



2



3



1

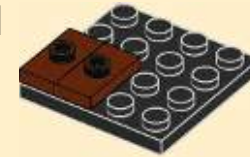

2

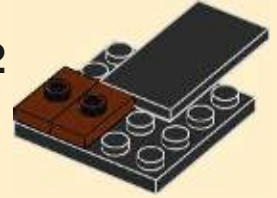

4

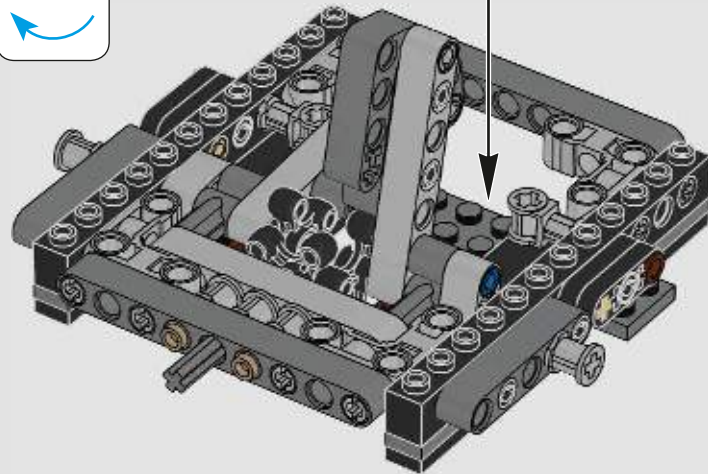
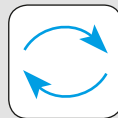
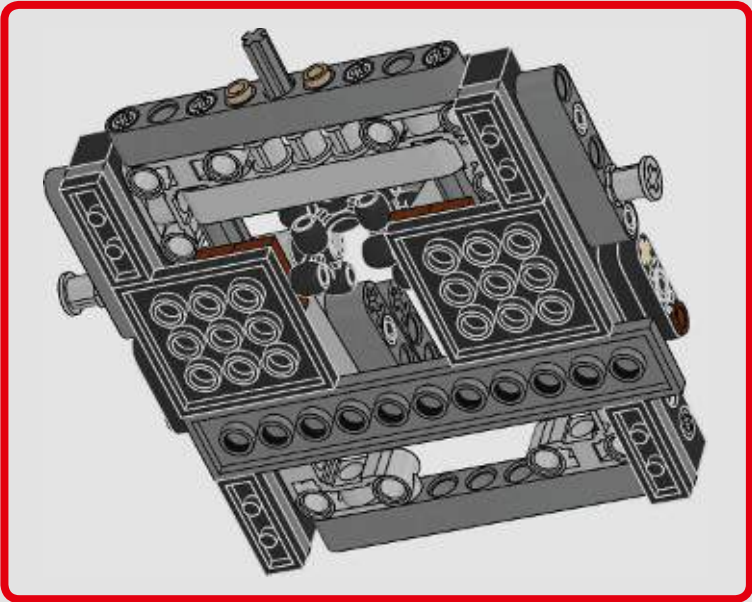
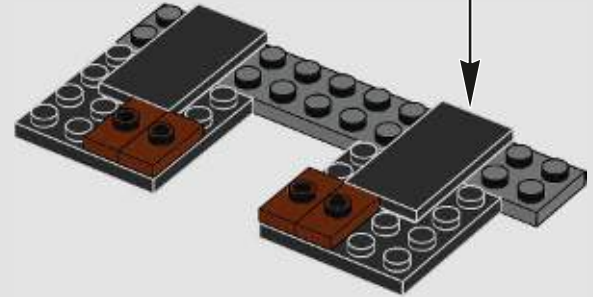

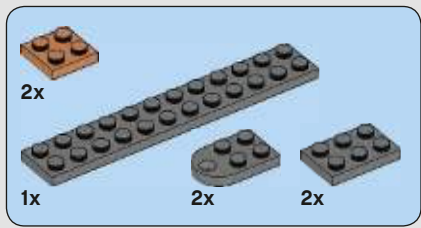

32

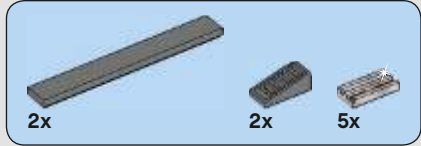
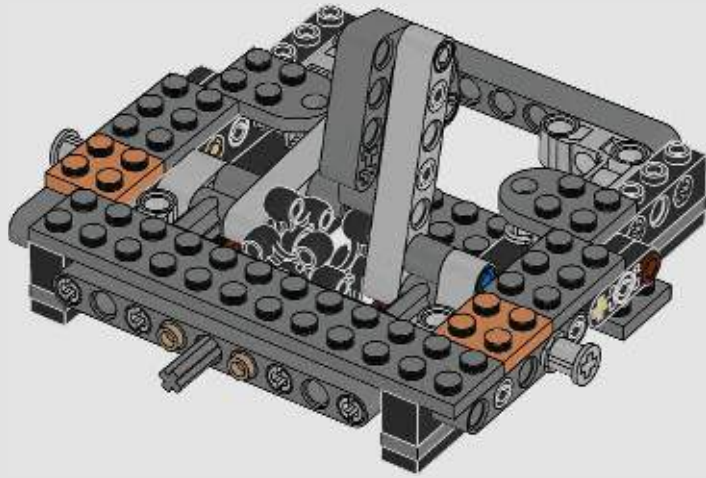

33

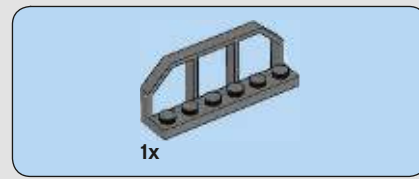
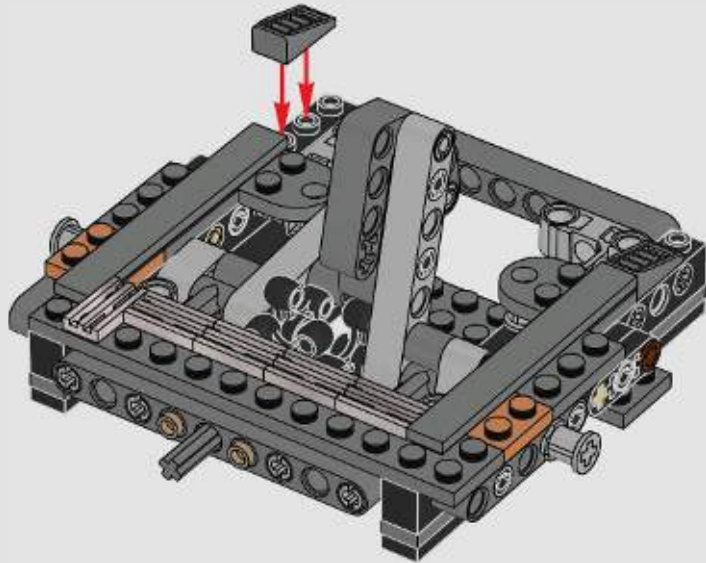

34

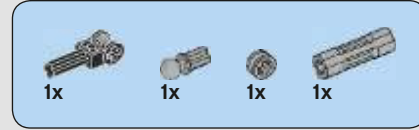
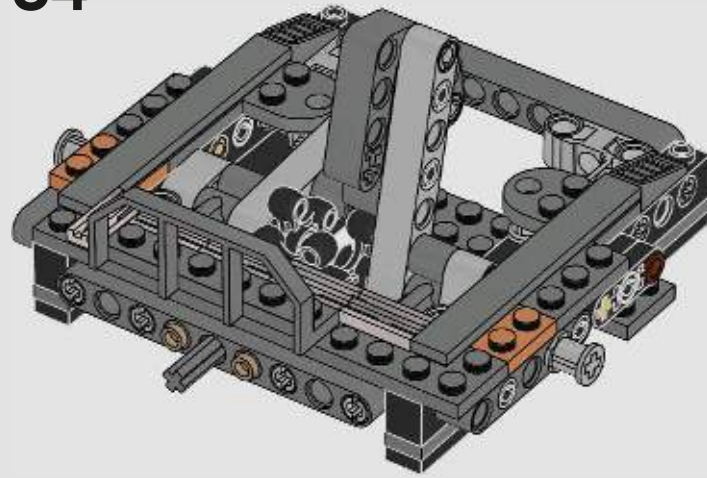

35

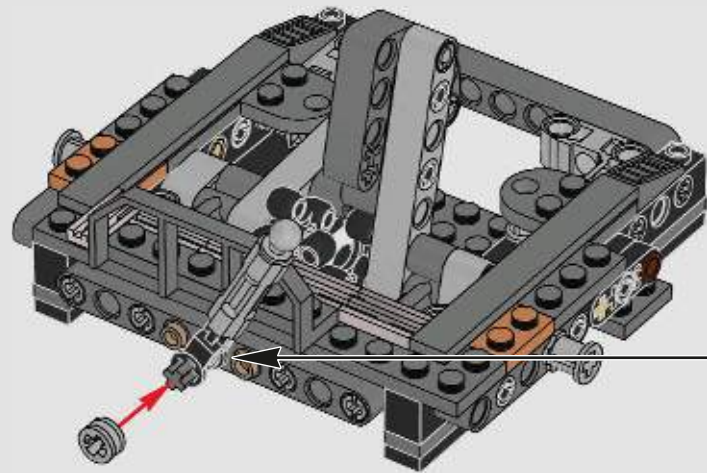
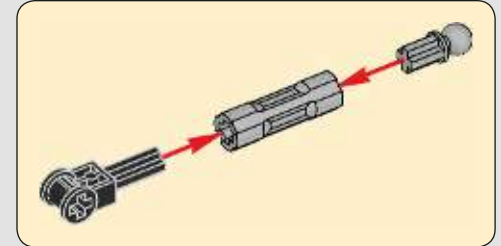

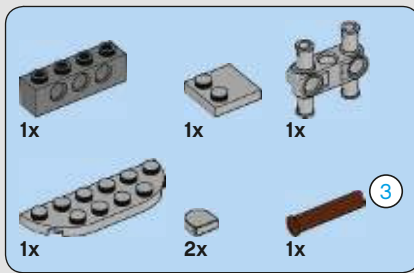

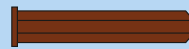
 ③ **1:1**

36

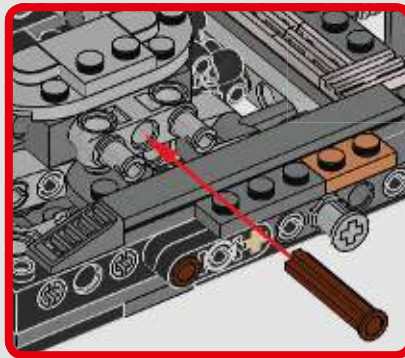
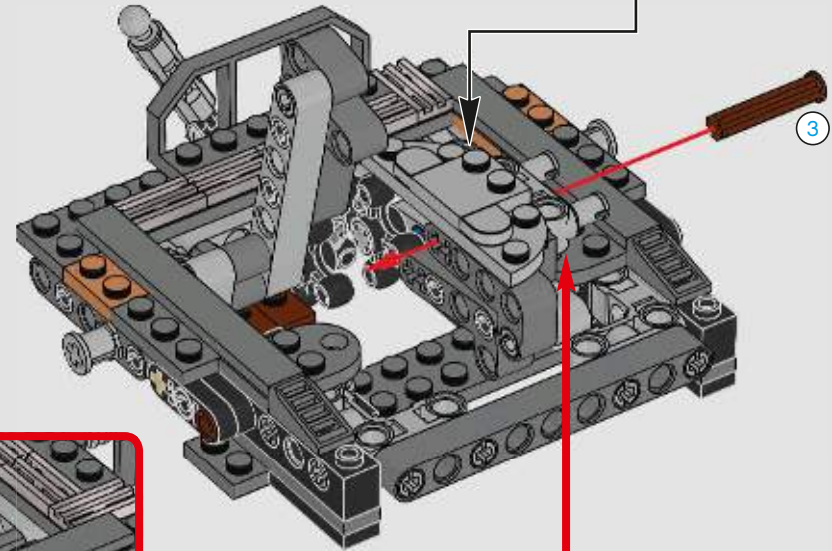
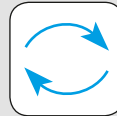
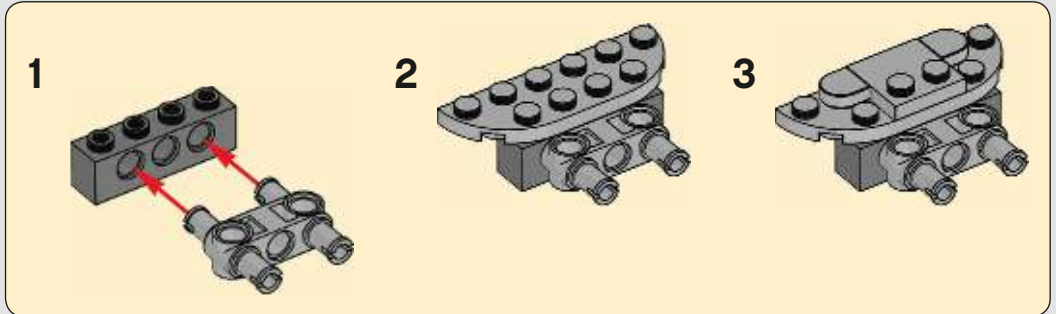
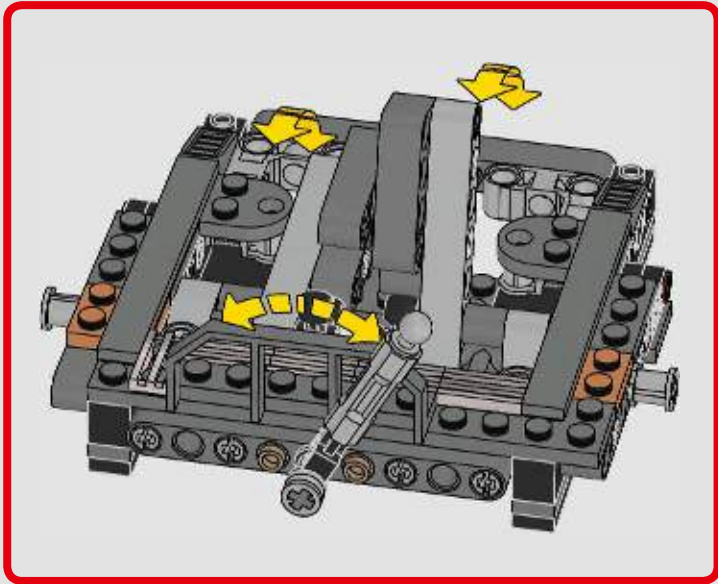



37

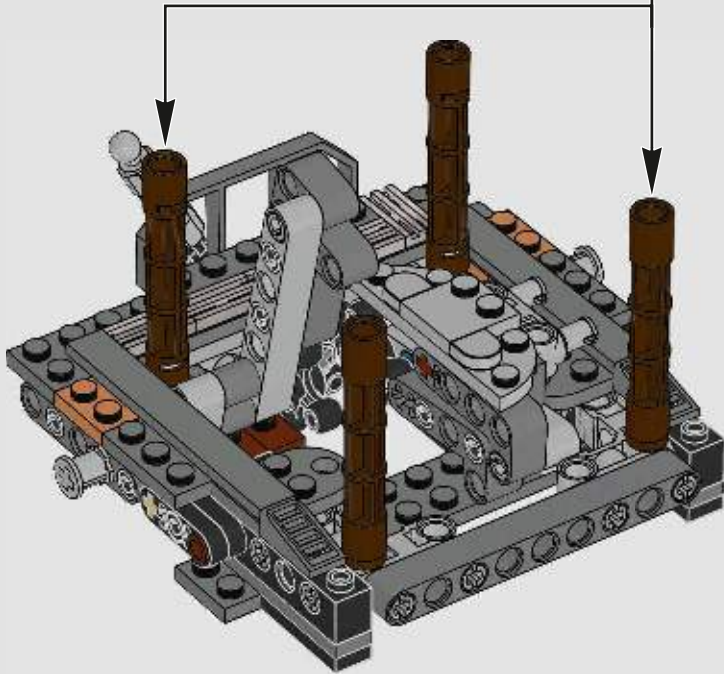
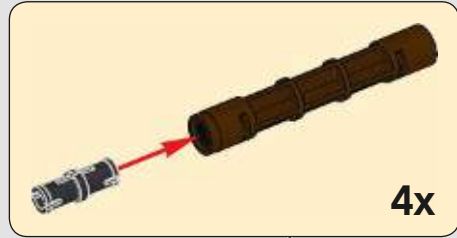

38

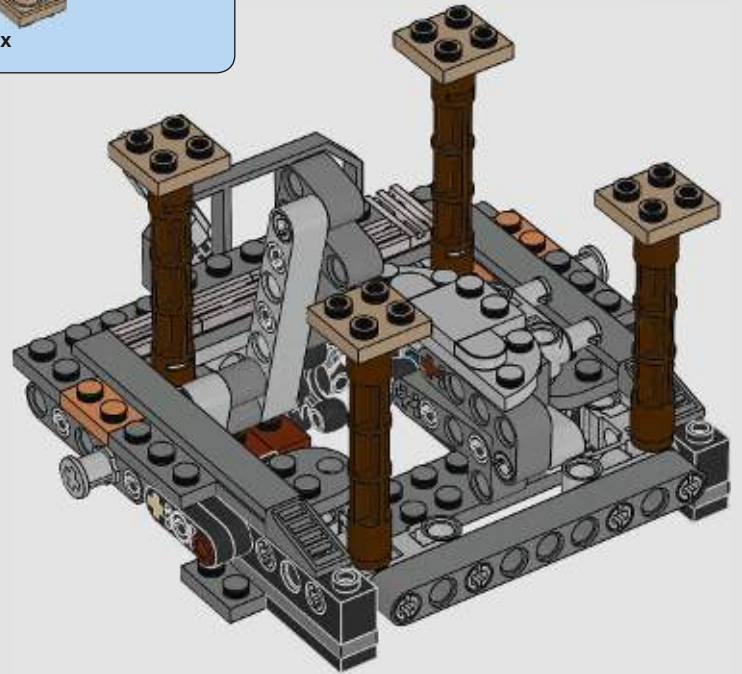

39

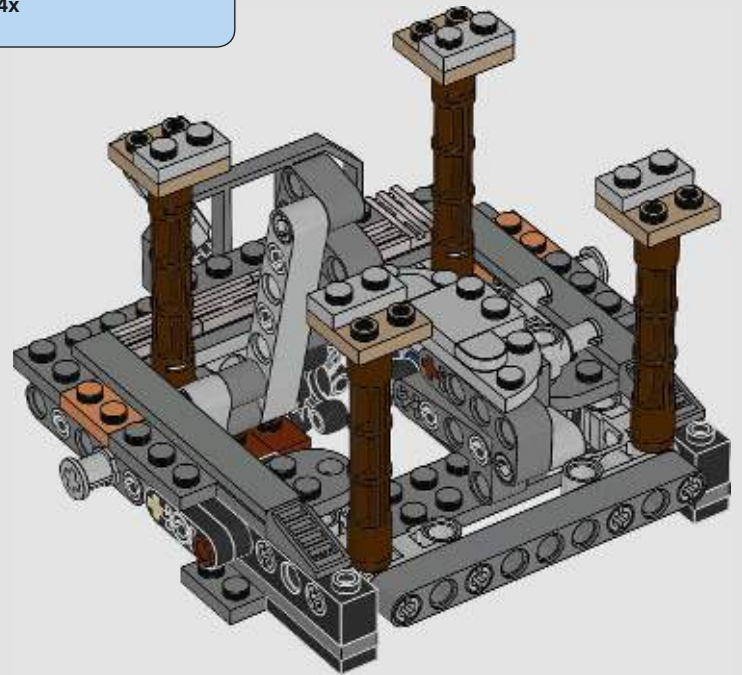

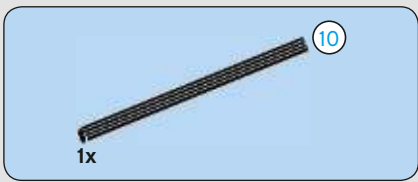

40

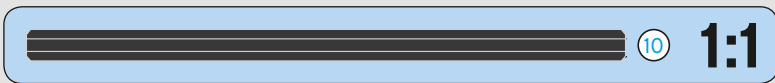
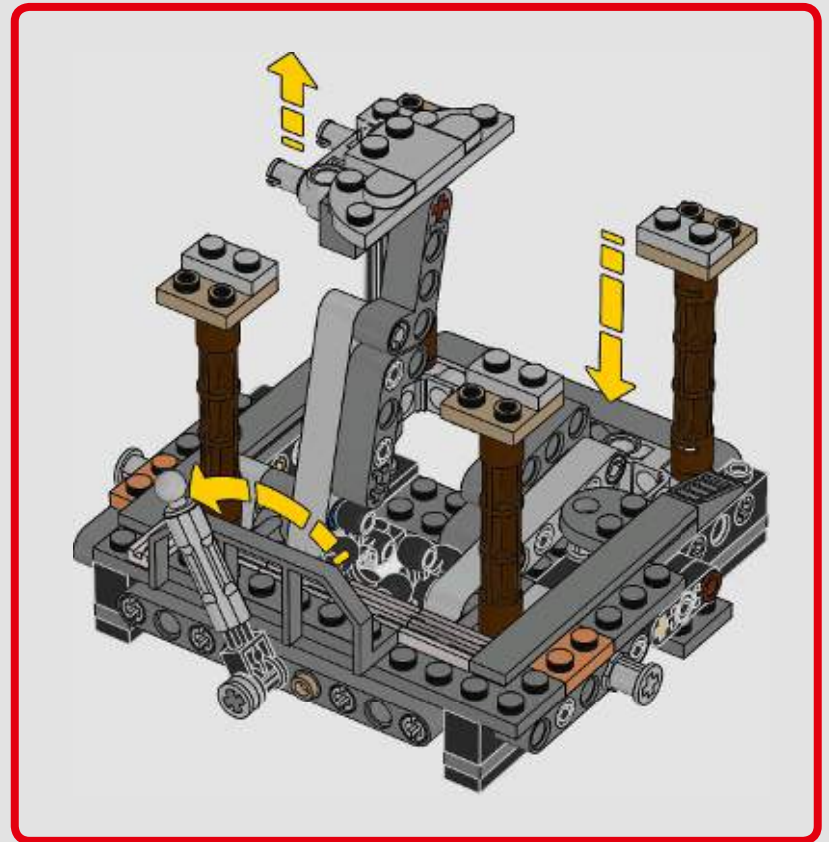
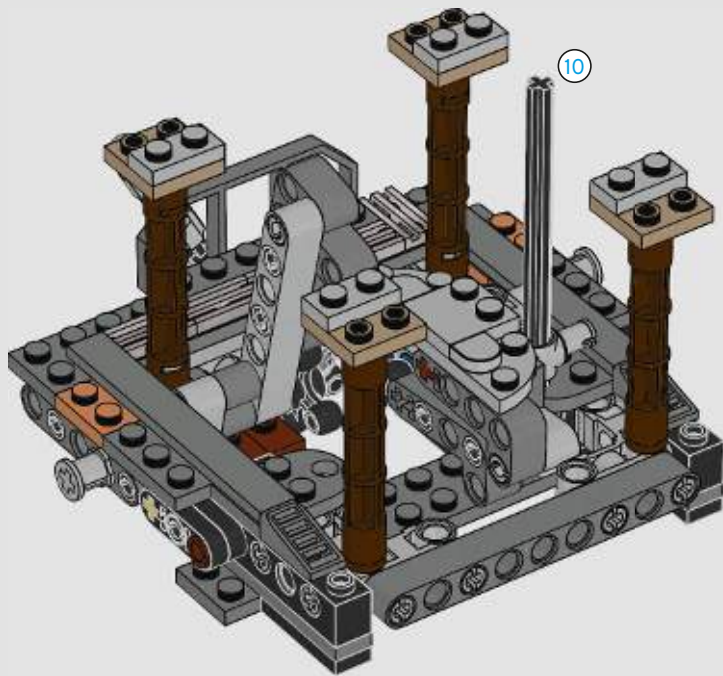

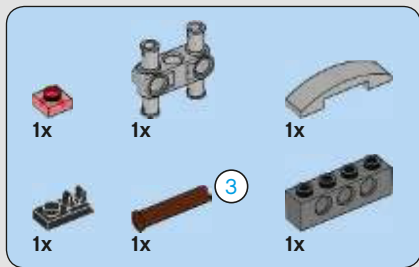

41

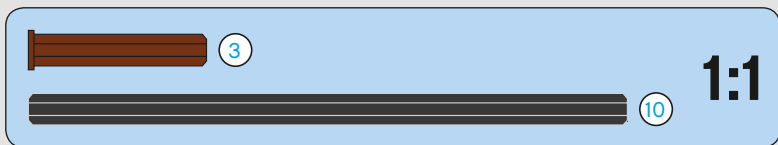
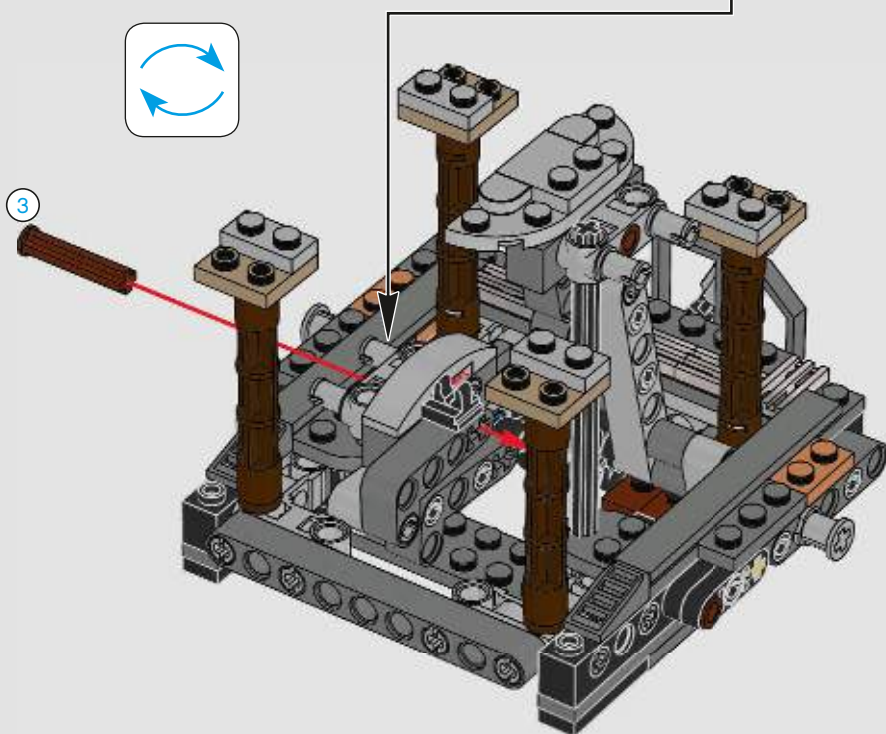
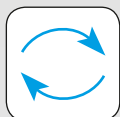
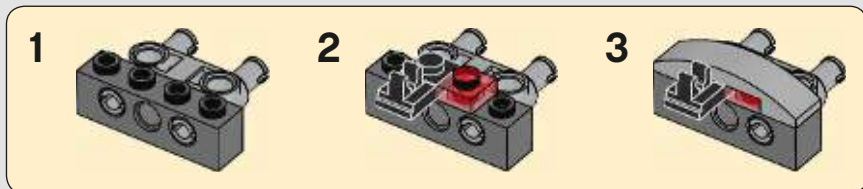

42

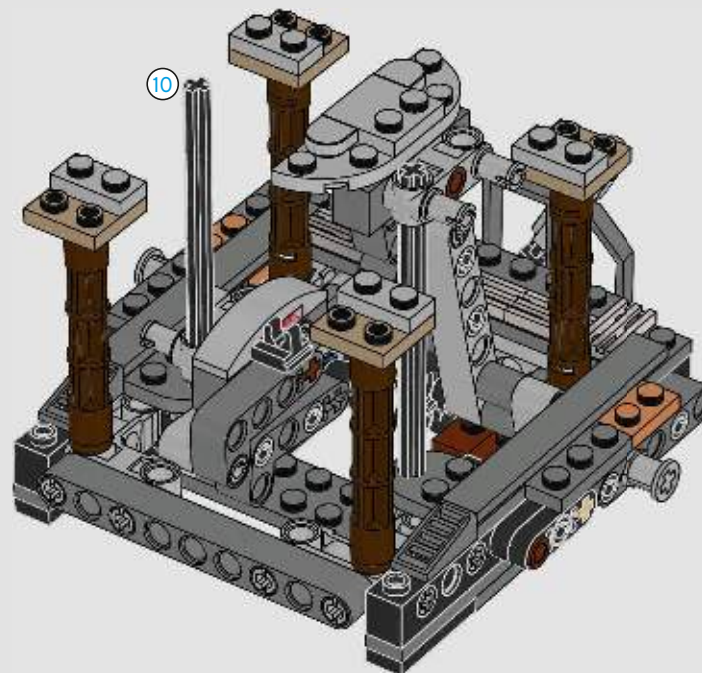



43

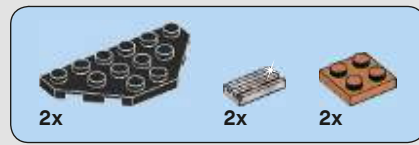
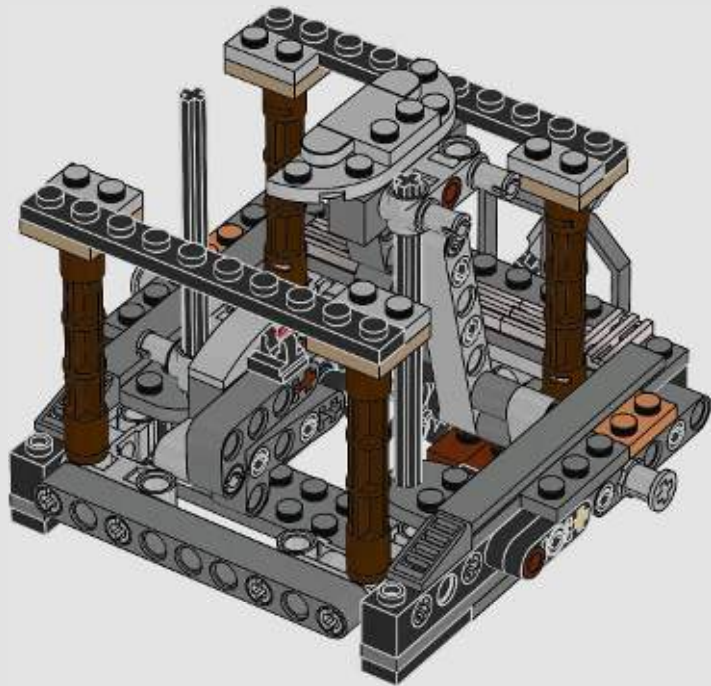

44

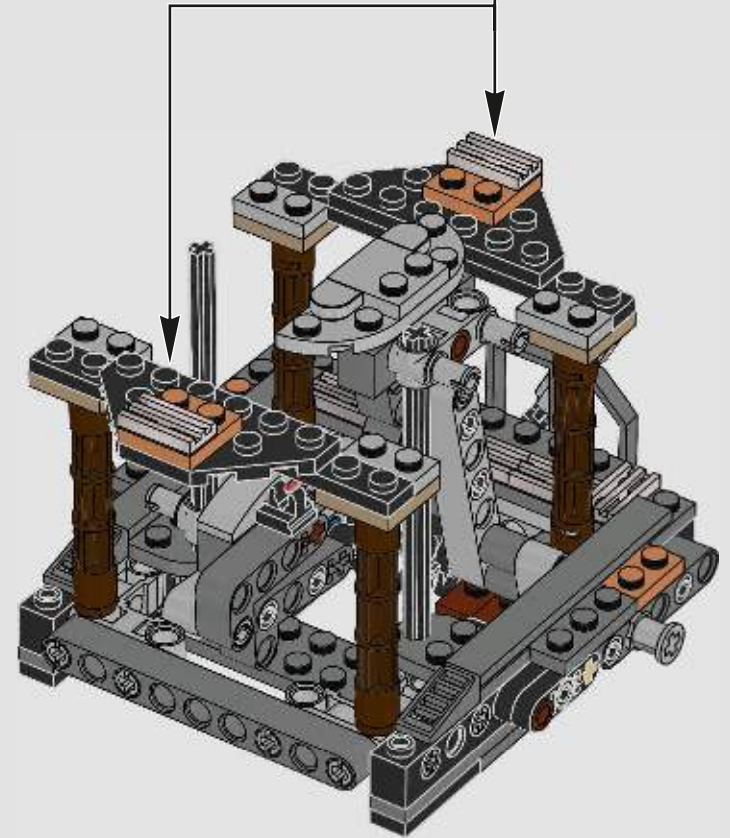
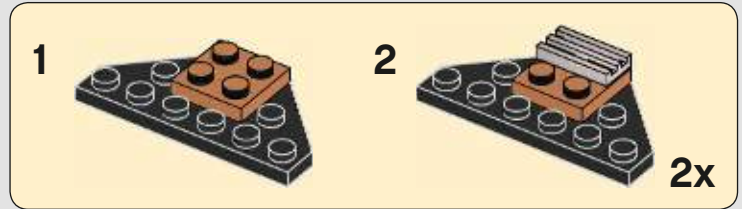



45

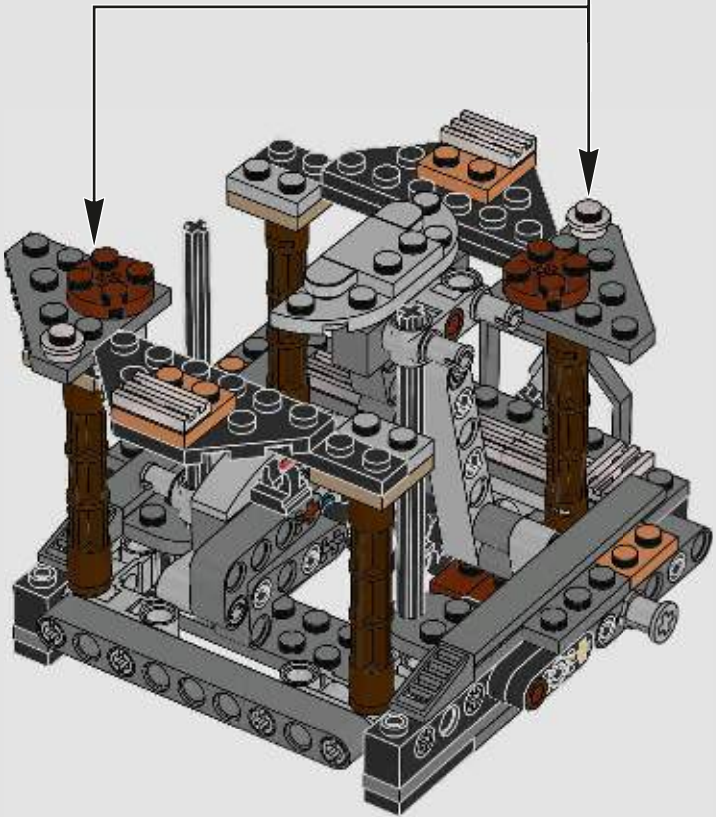
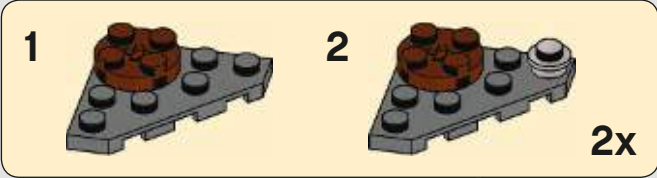

46

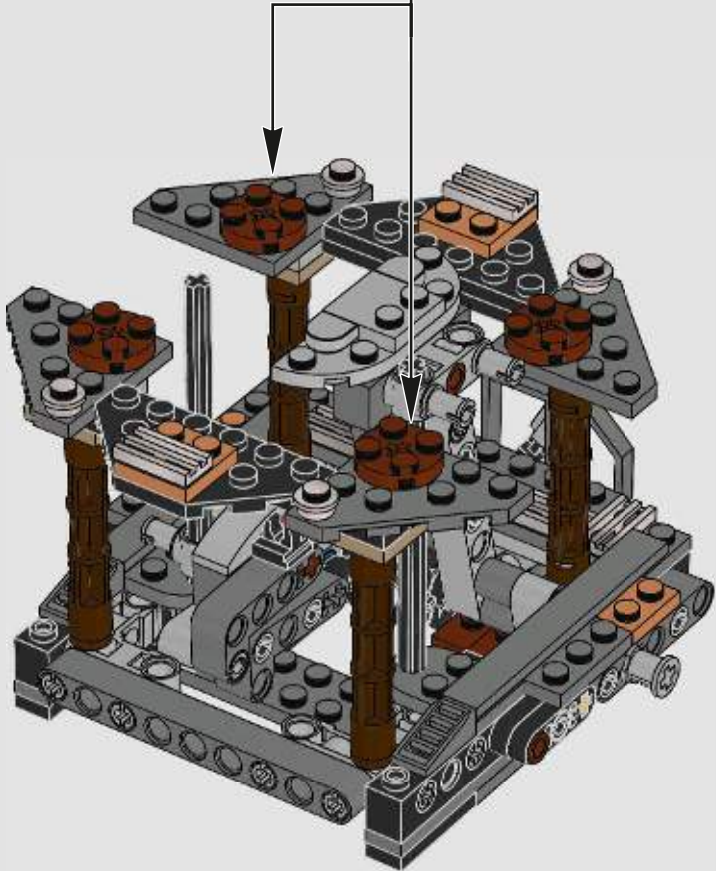
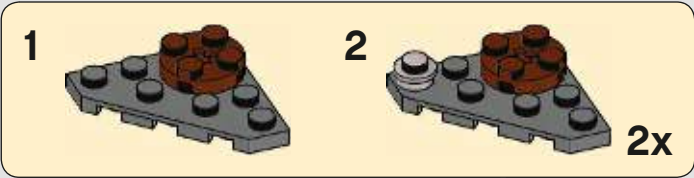



47

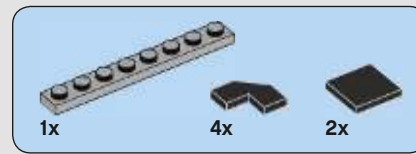
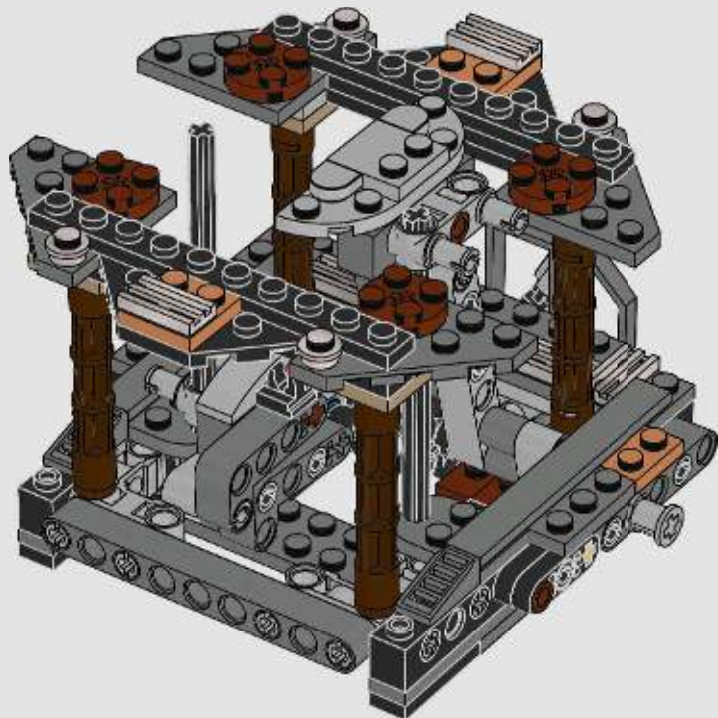

48

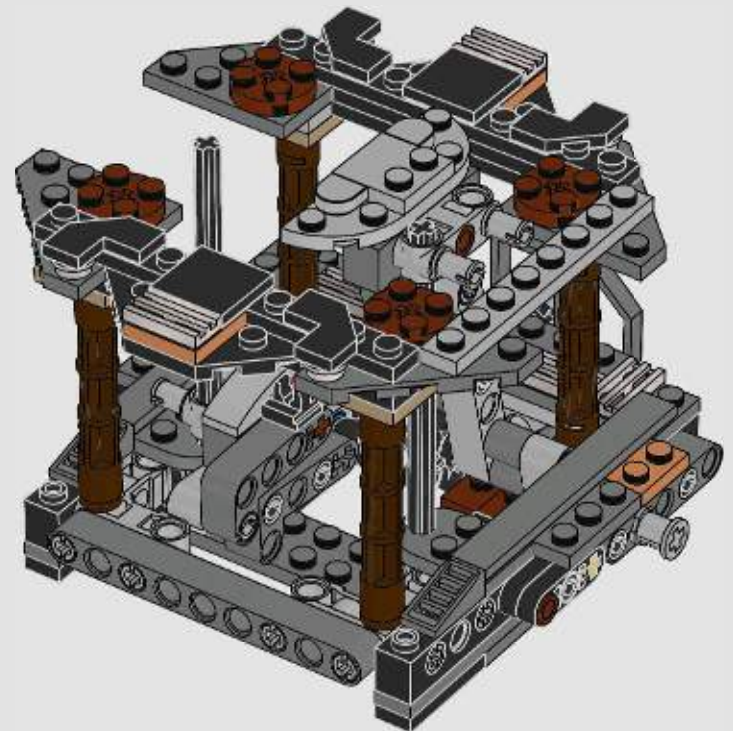



49

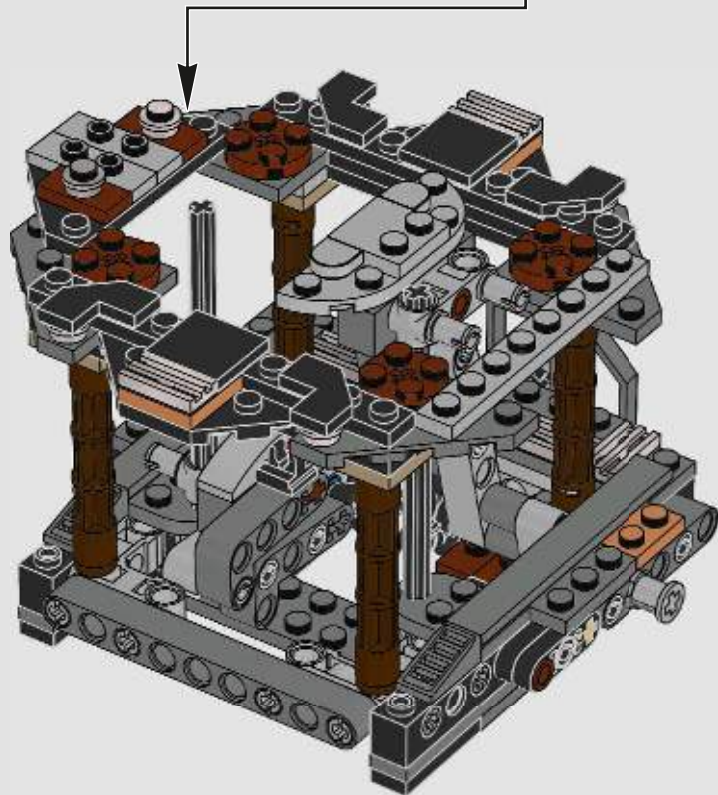
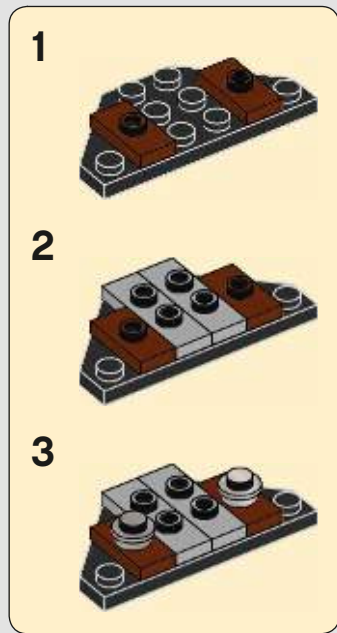

50

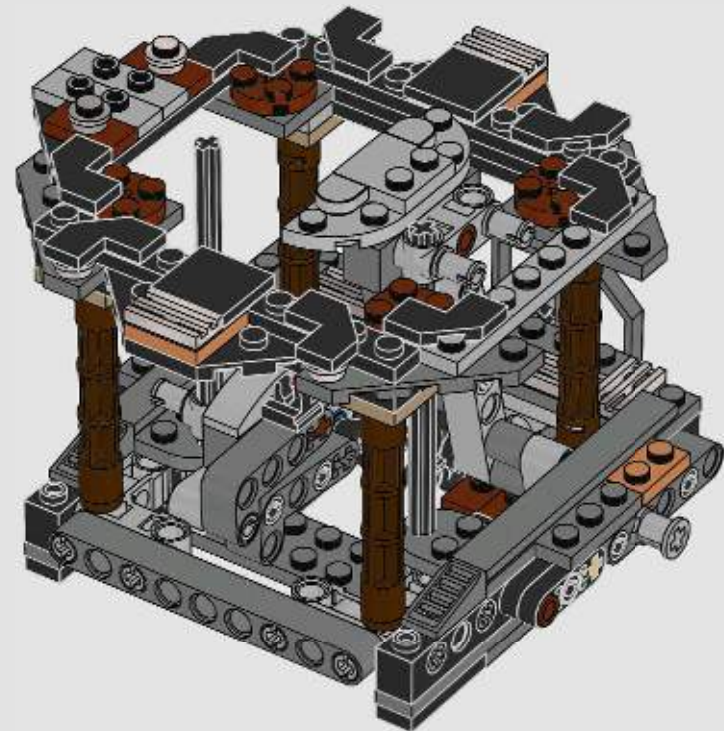

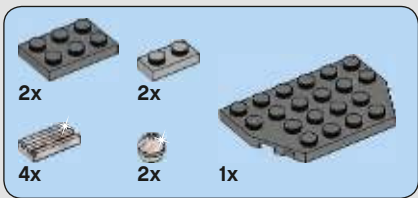

51

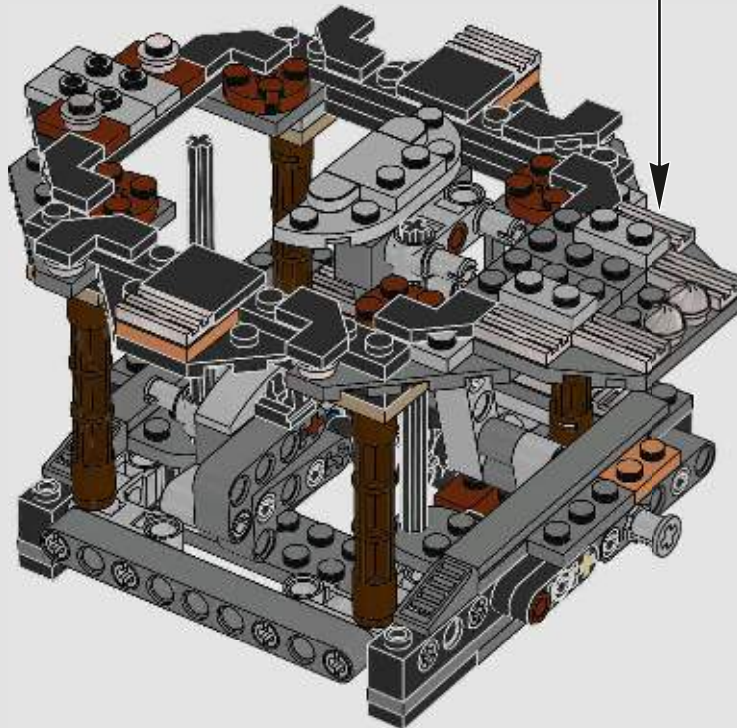
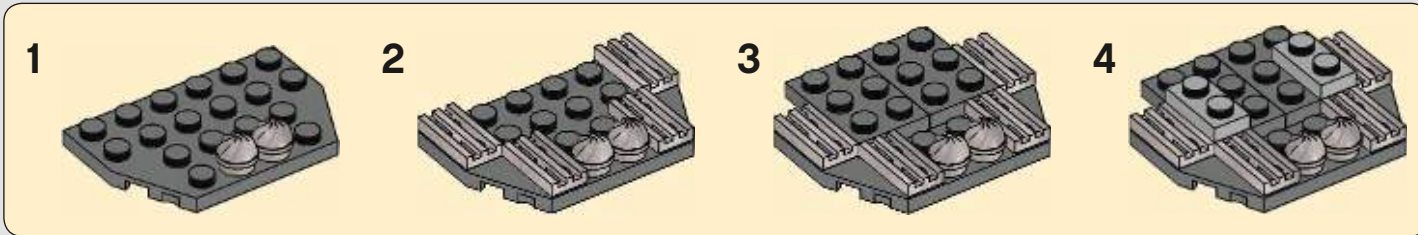

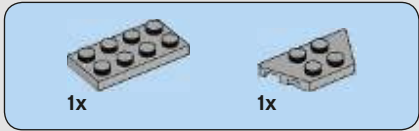
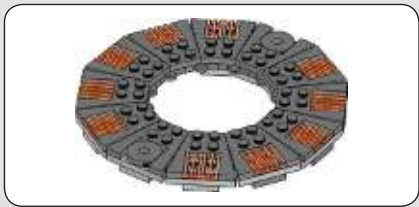

52

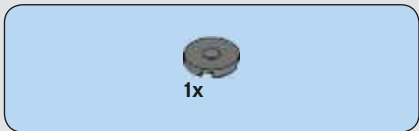
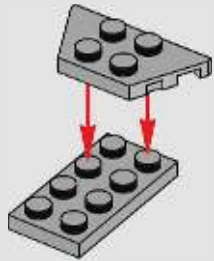

53

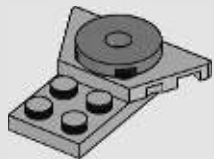

54

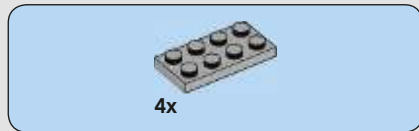

55

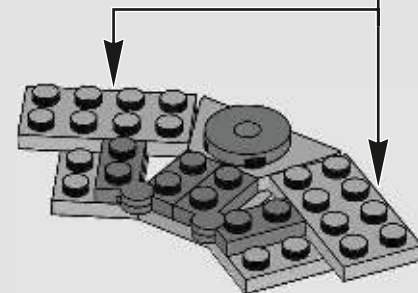
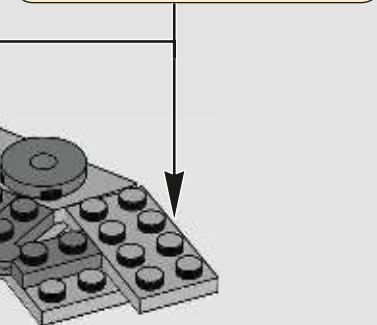
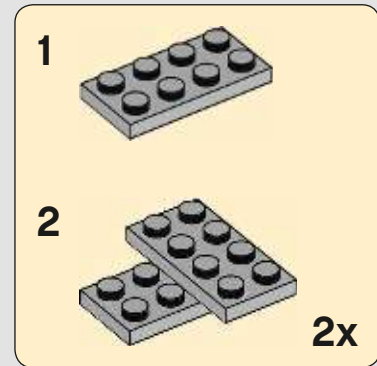



56

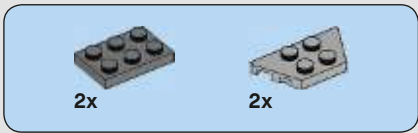
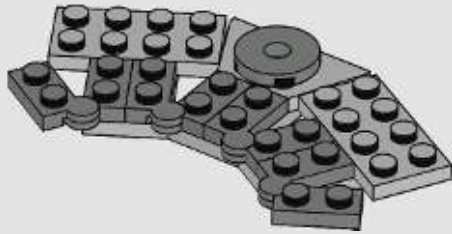

57

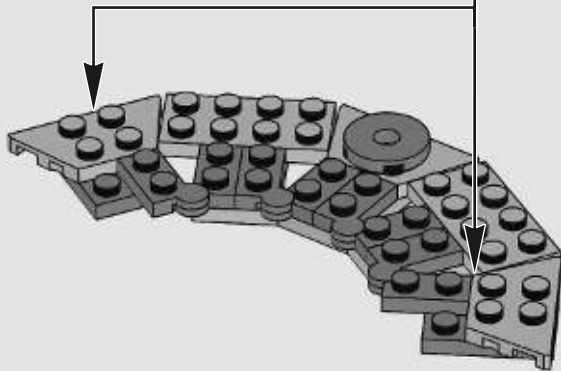
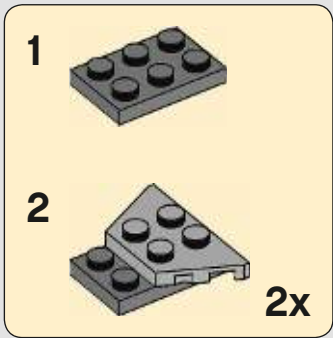

58

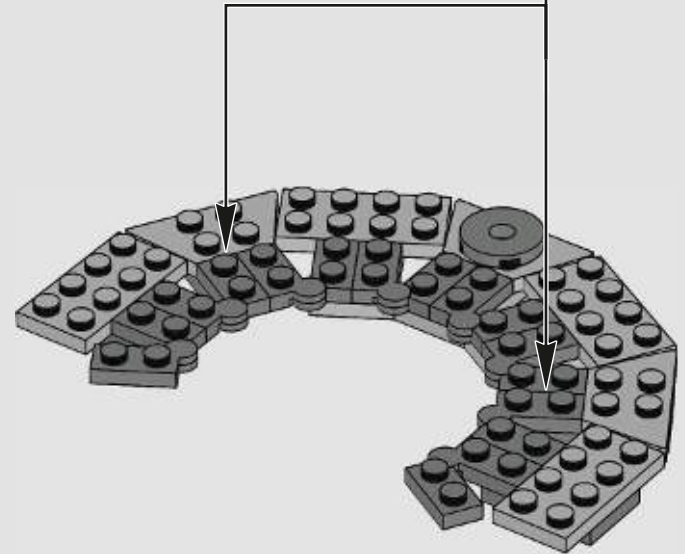



59

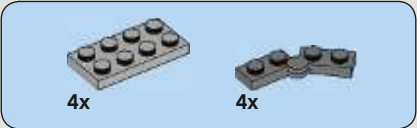
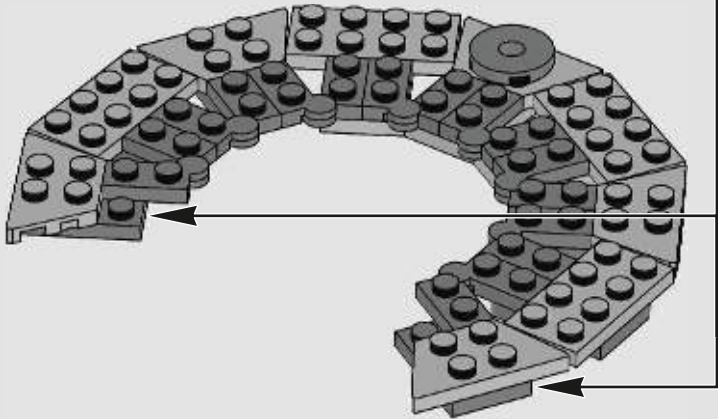
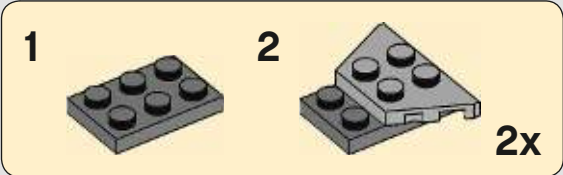

60

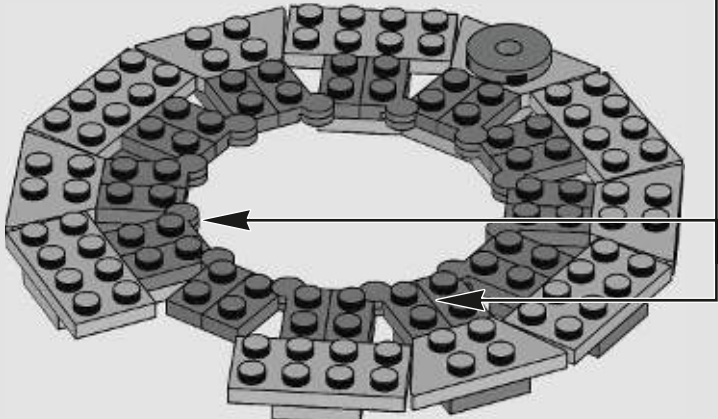
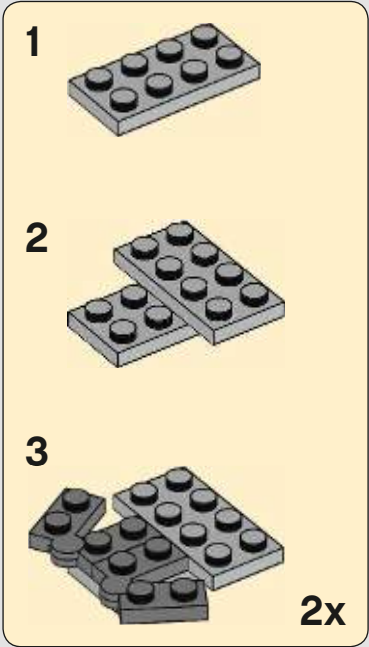

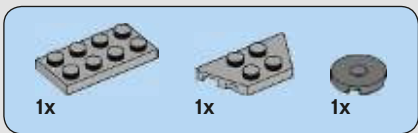

61

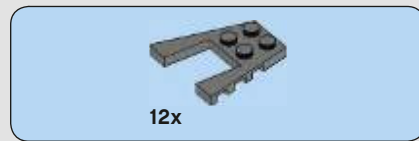
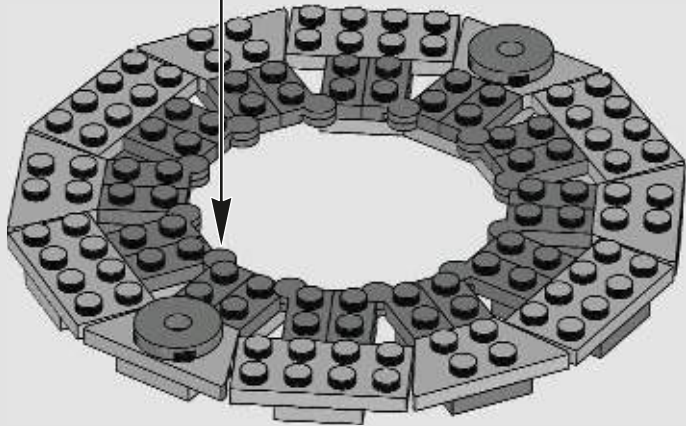
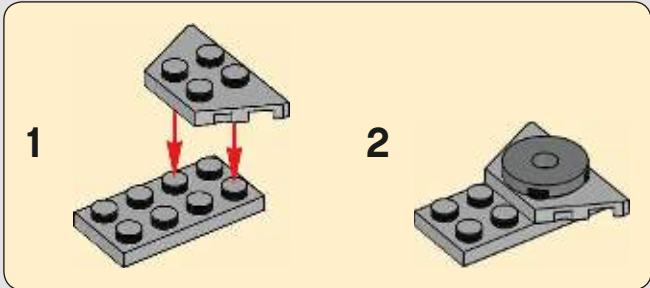

62

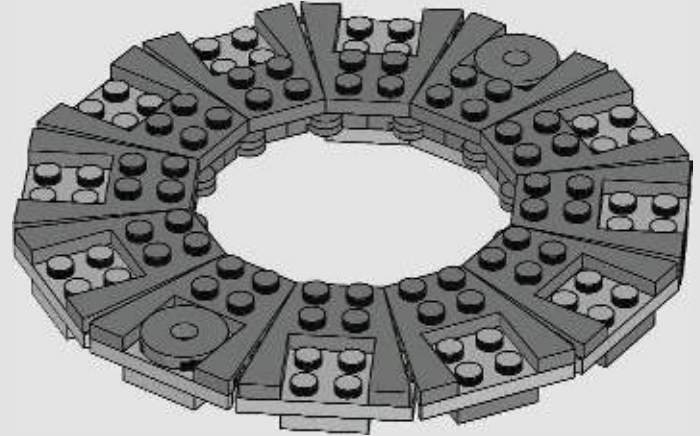

63

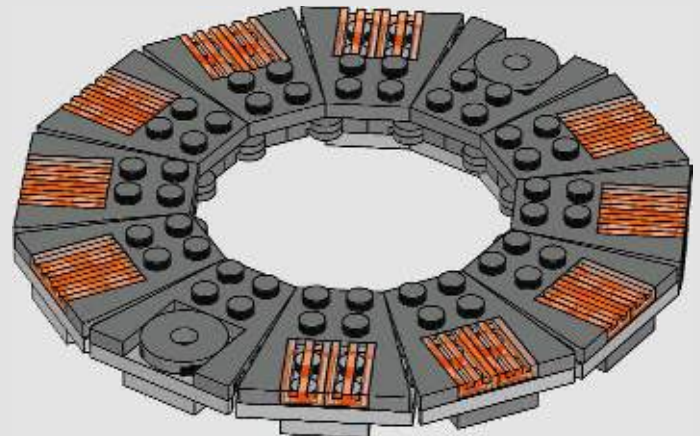

64

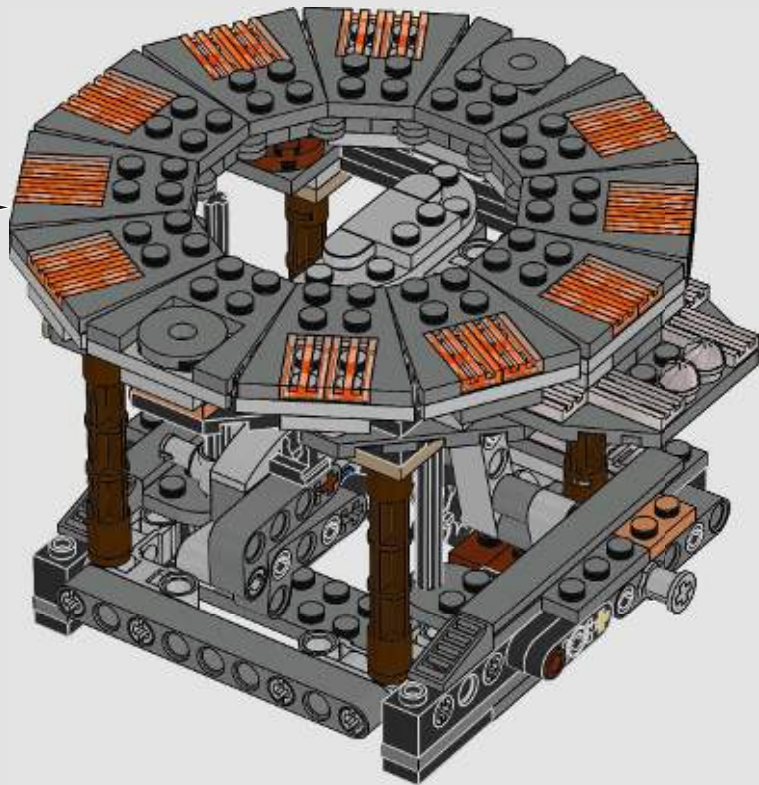

65

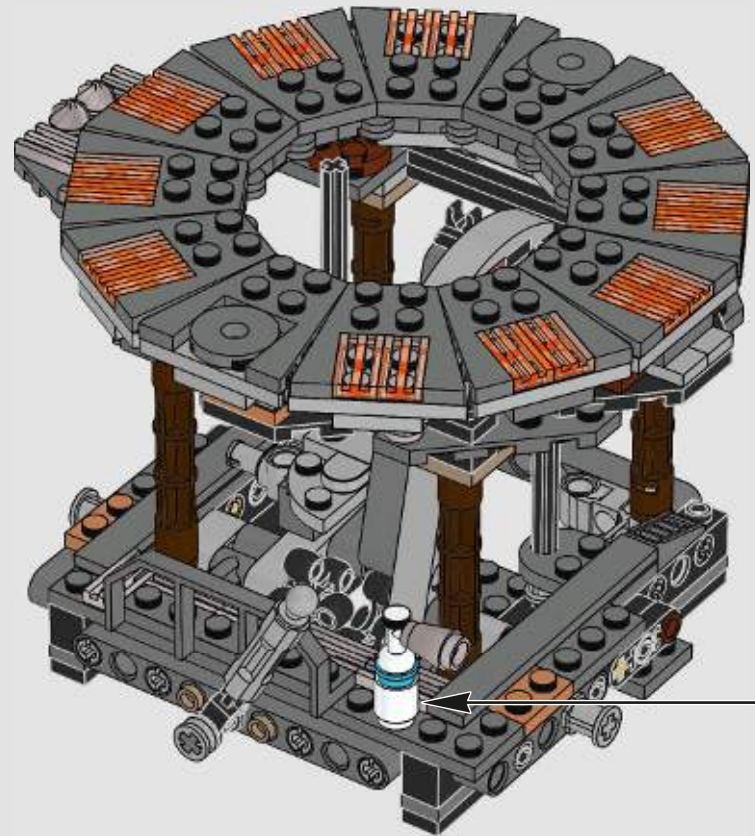
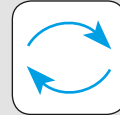
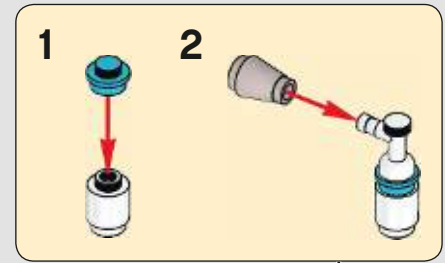
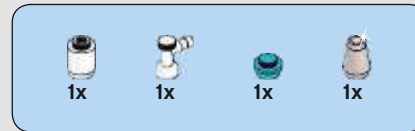

1



2

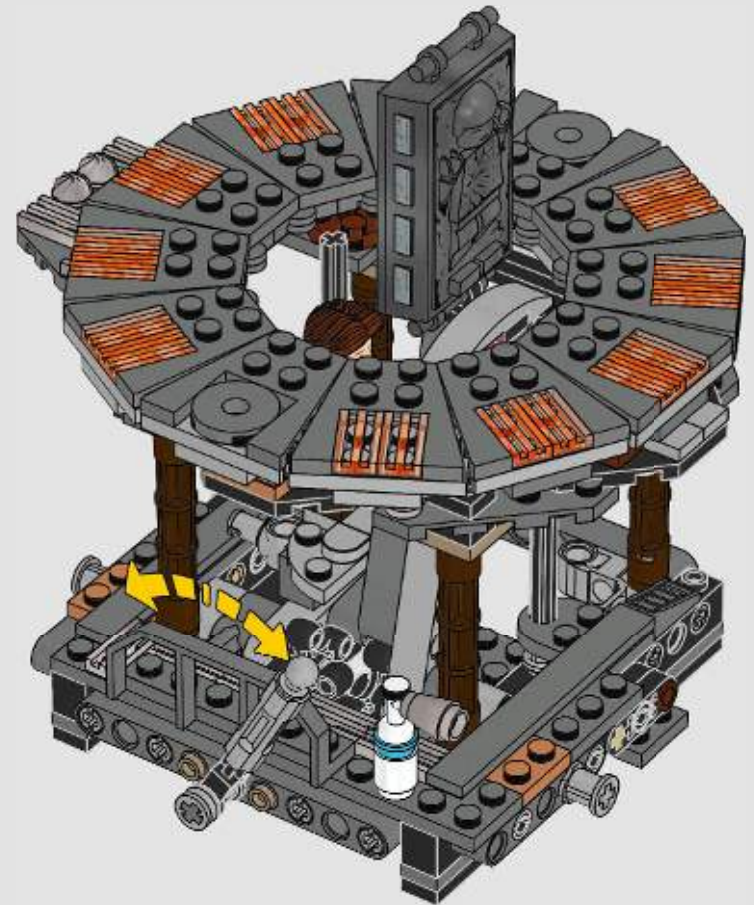

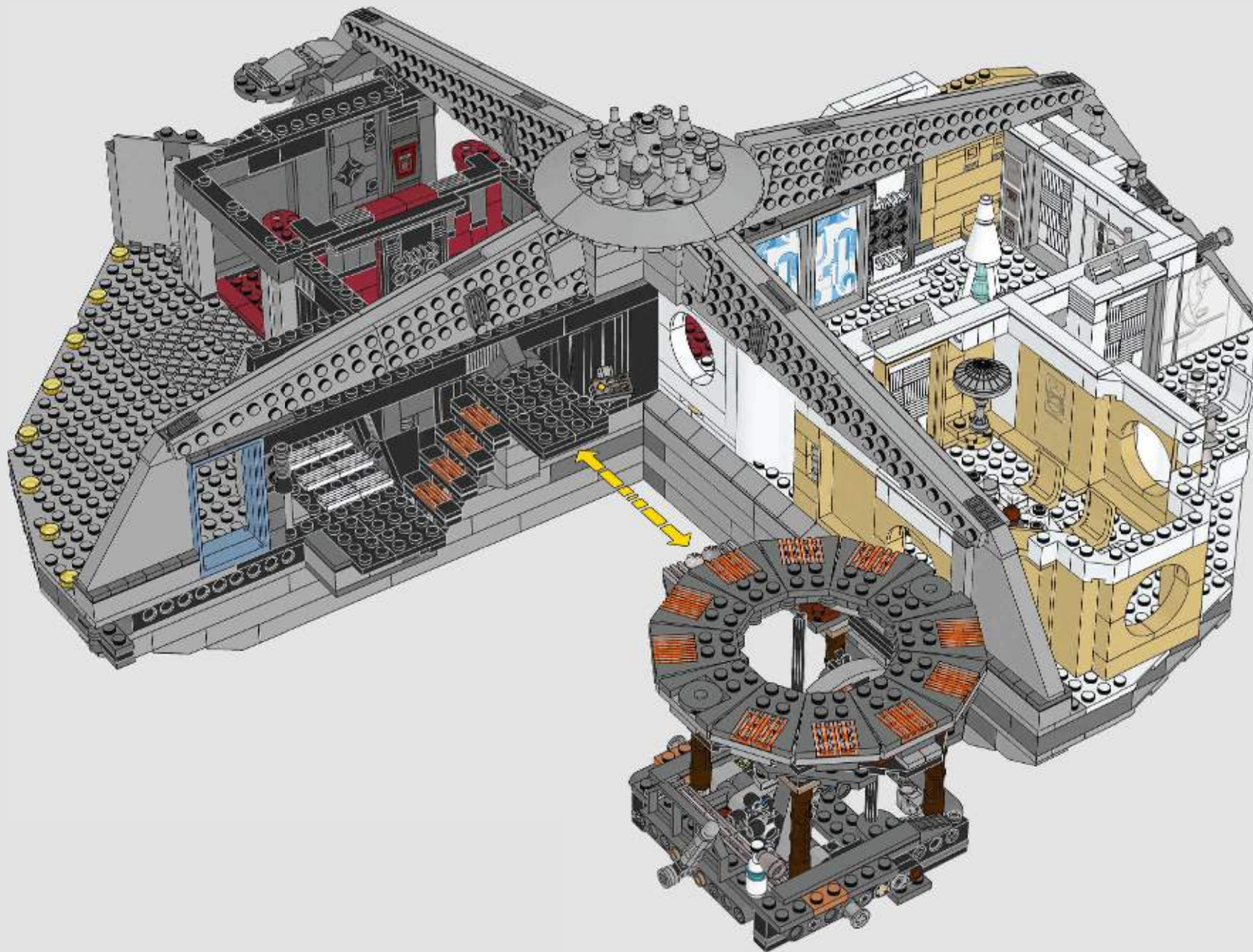

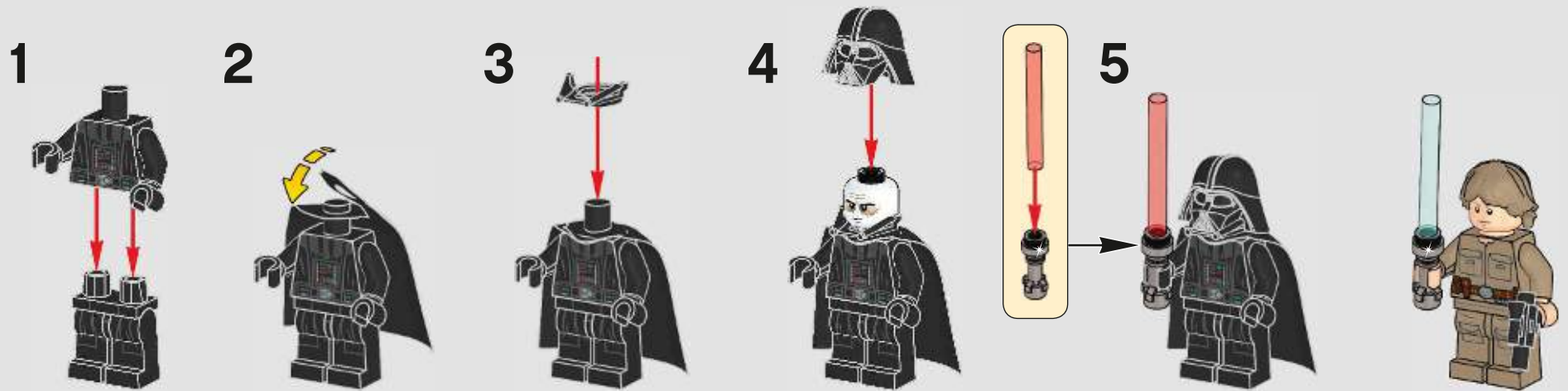
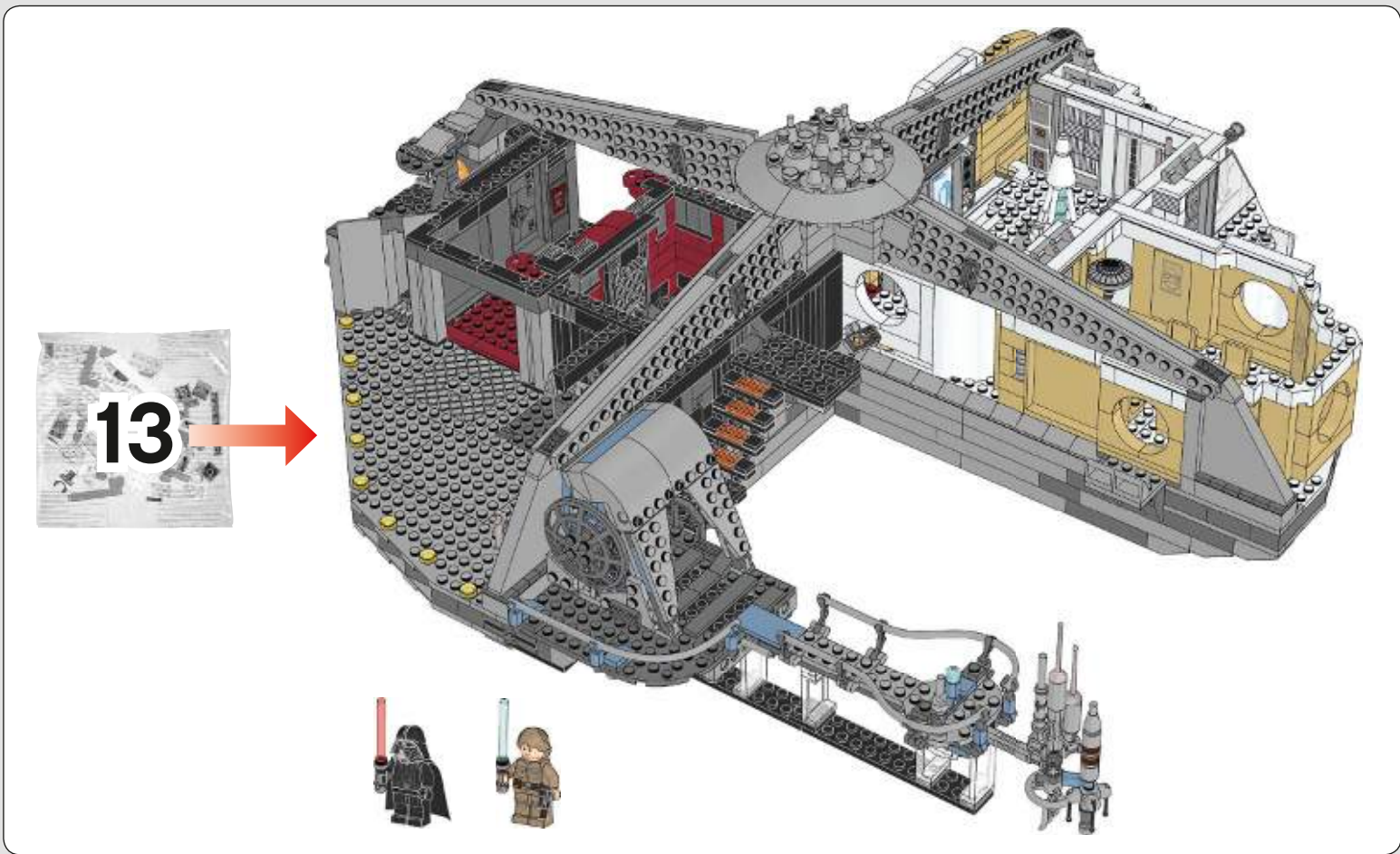

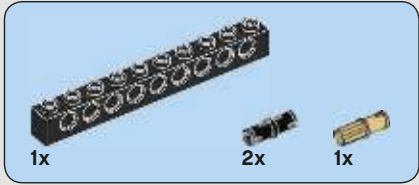
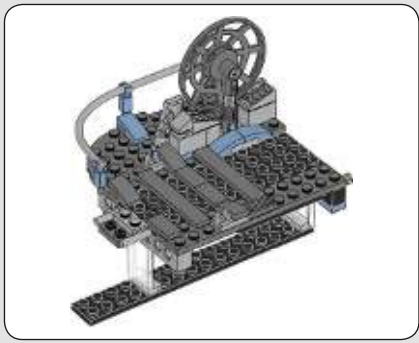

281

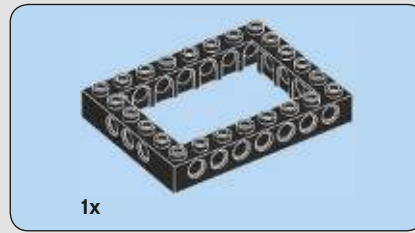
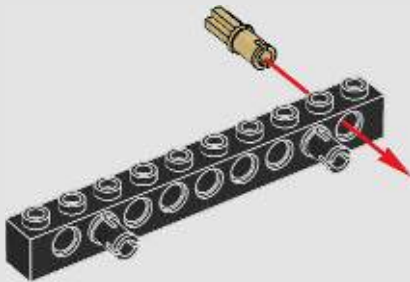

282

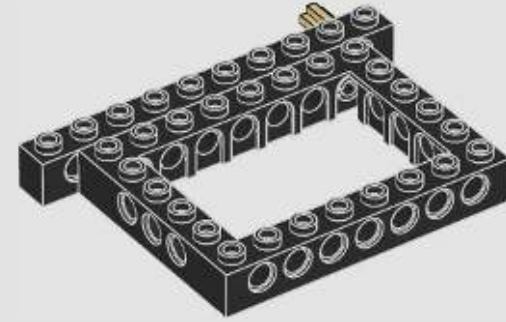

283

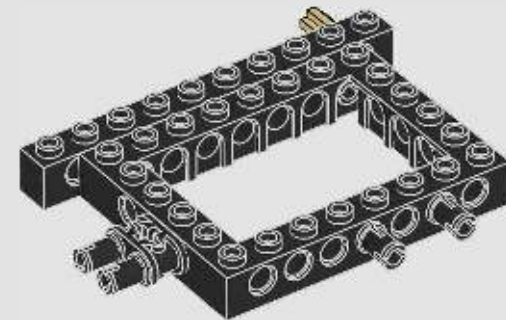

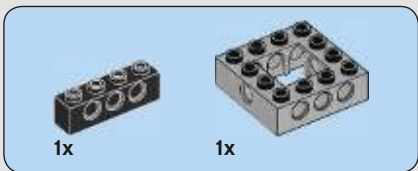

284

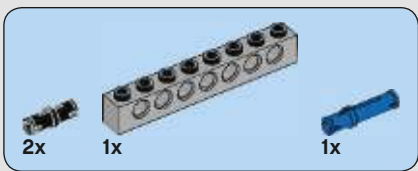
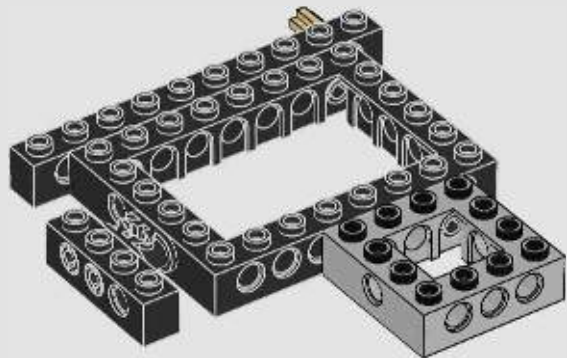

285

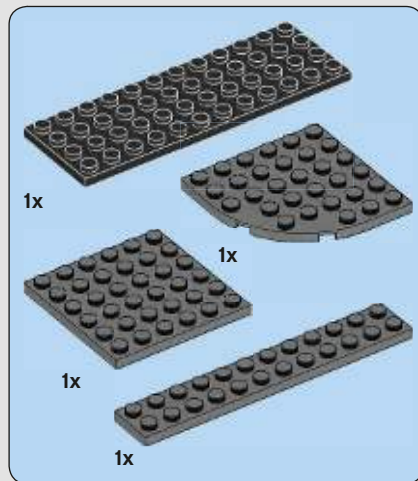
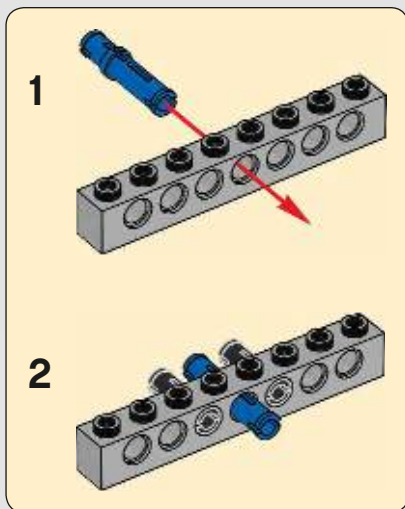
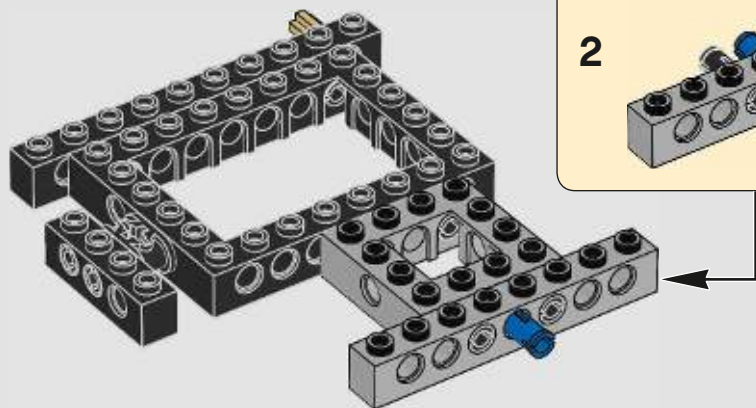

286

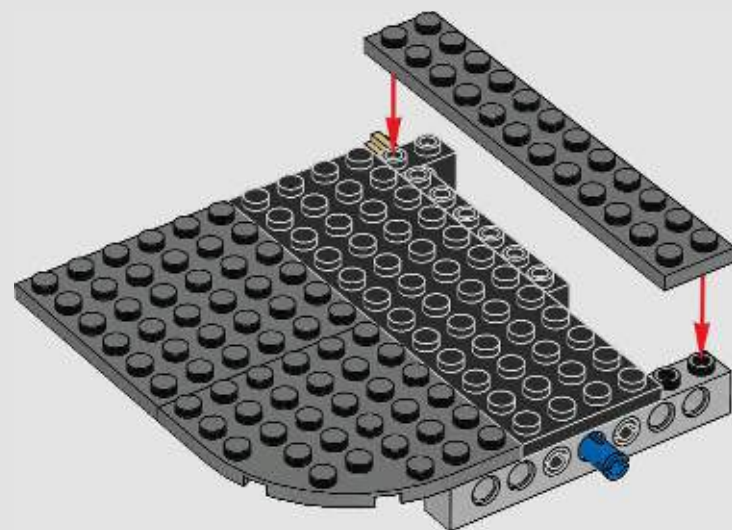

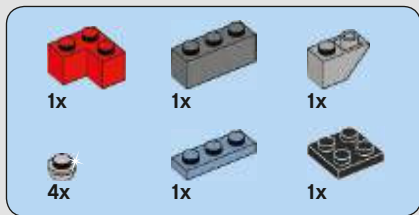

287

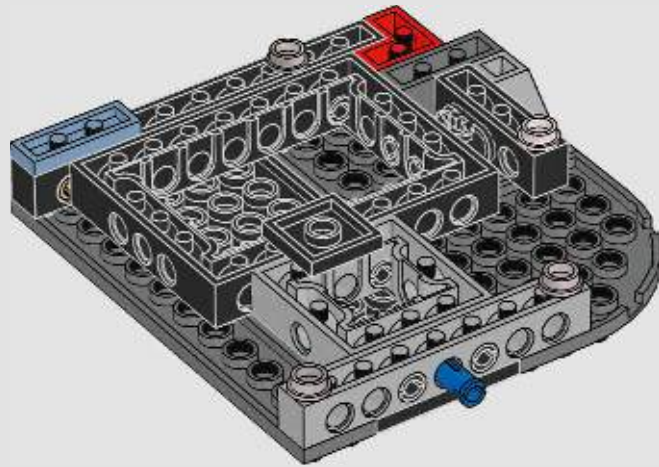

288

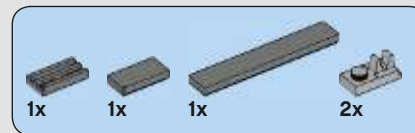
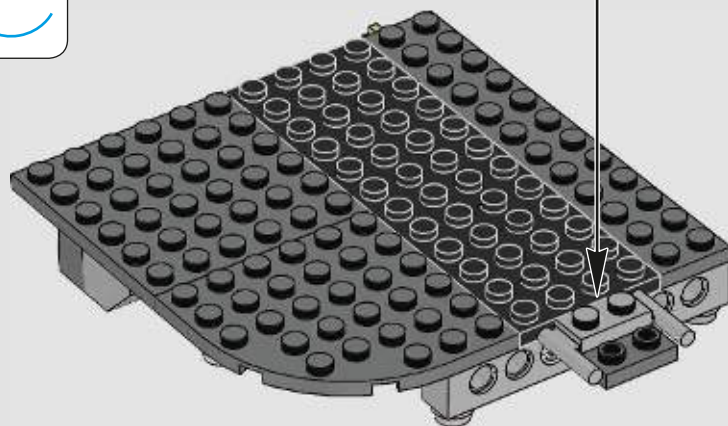

289

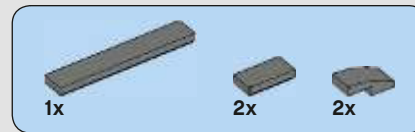
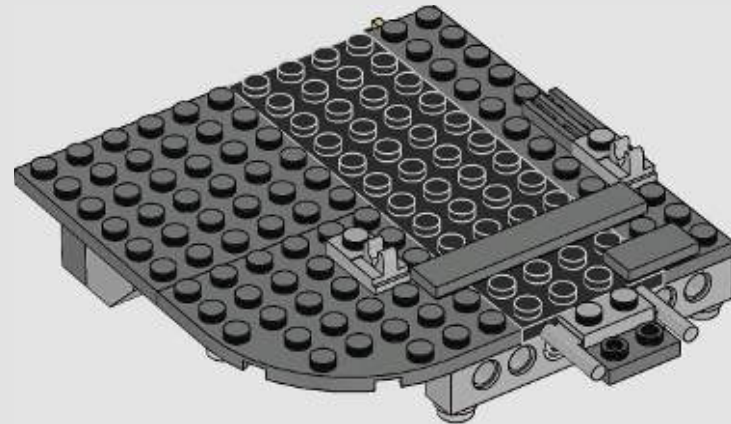

290

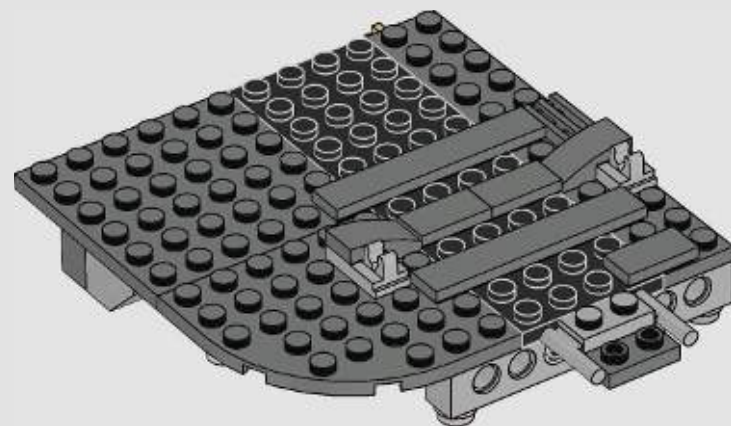

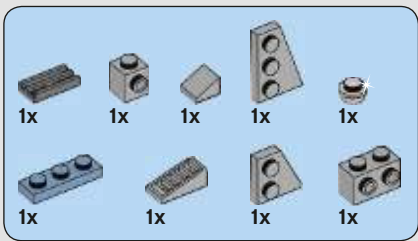

291

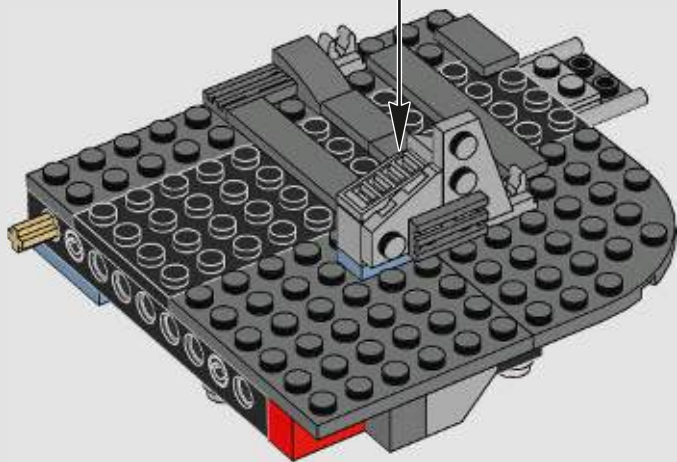
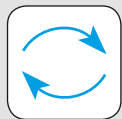
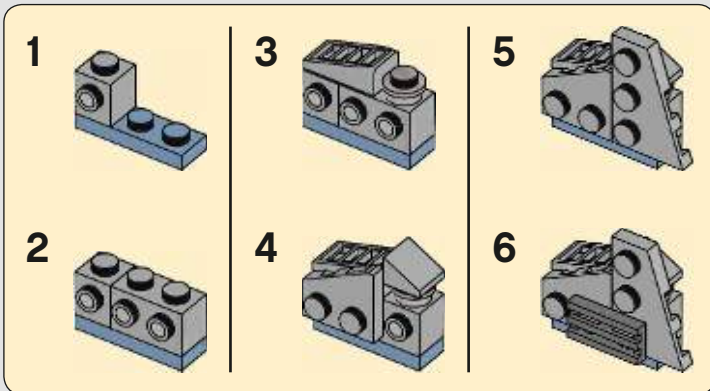

292

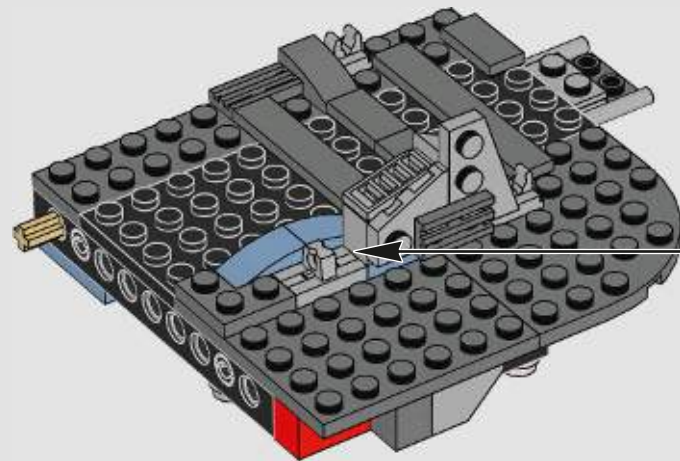
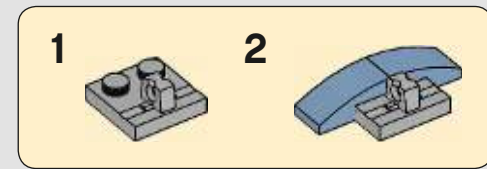

293

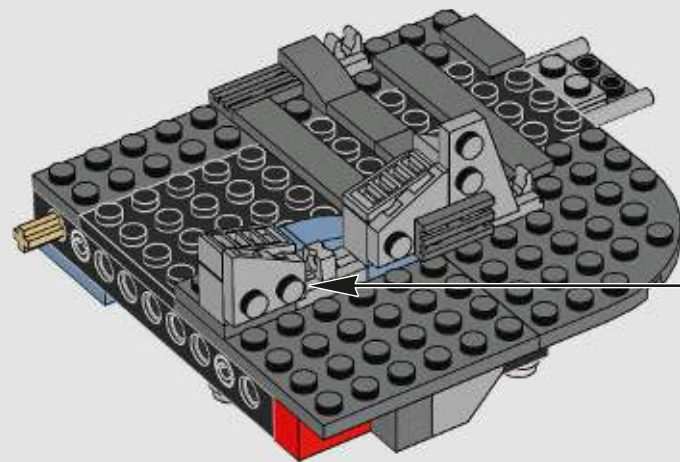
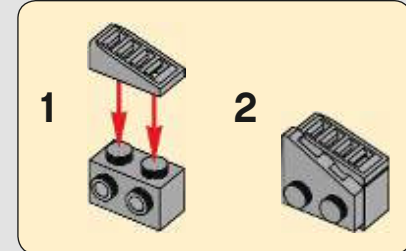



3x



3x

294

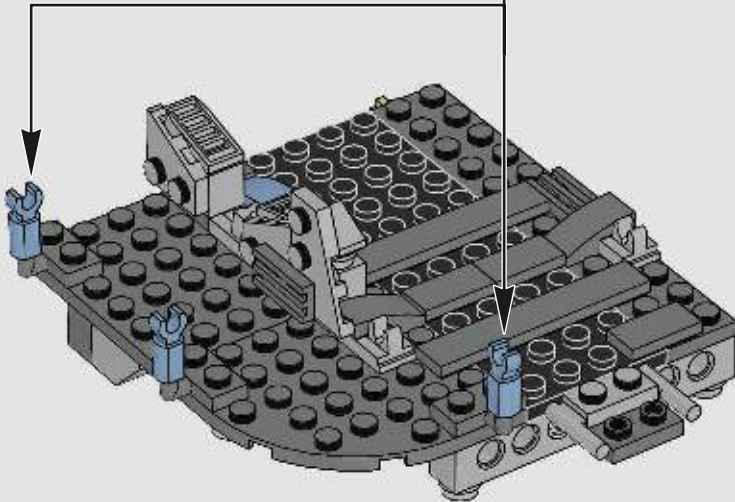
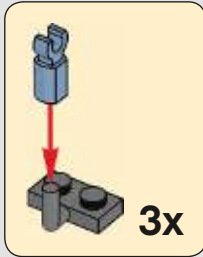

1x



2x

295

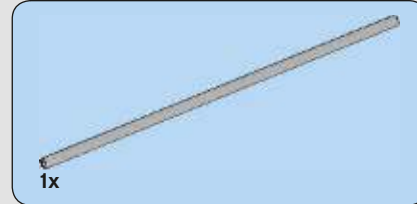
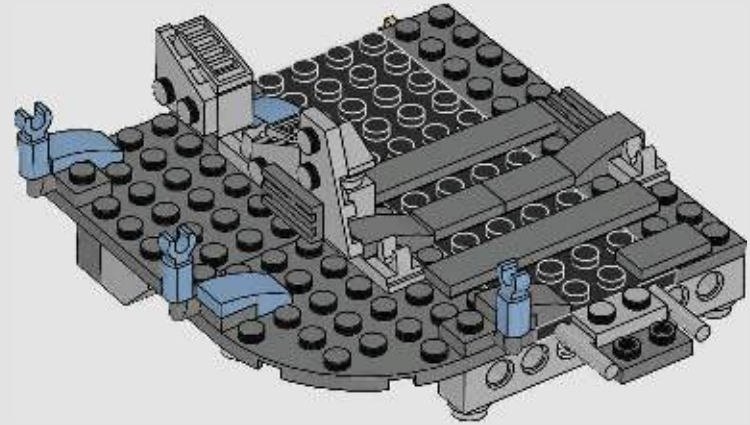

296

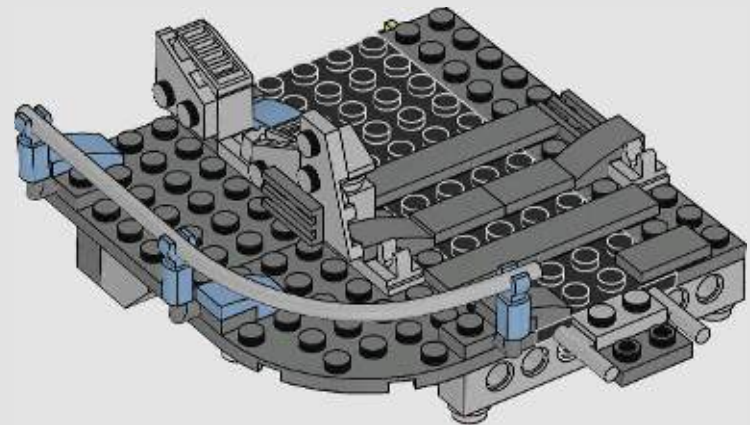

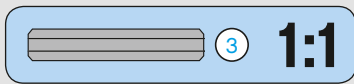
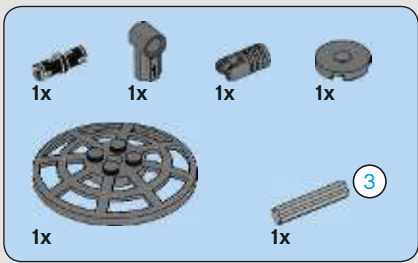

297

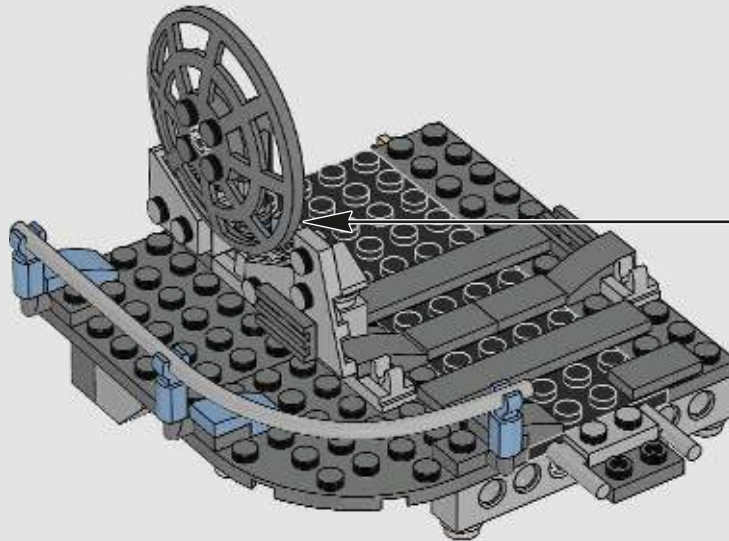
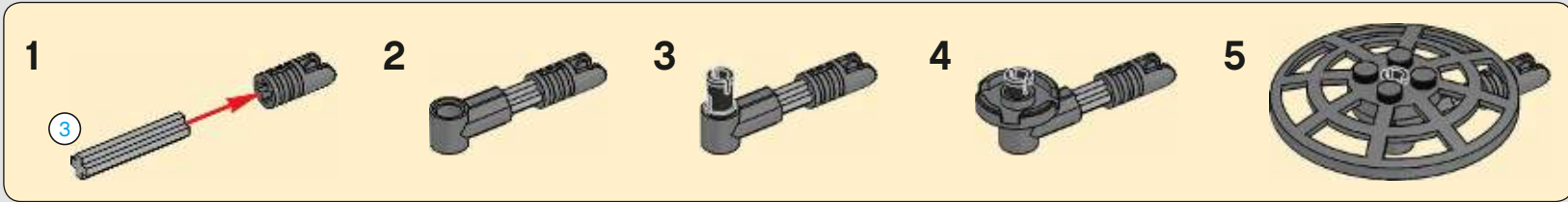

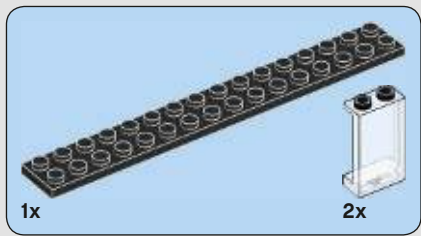

298

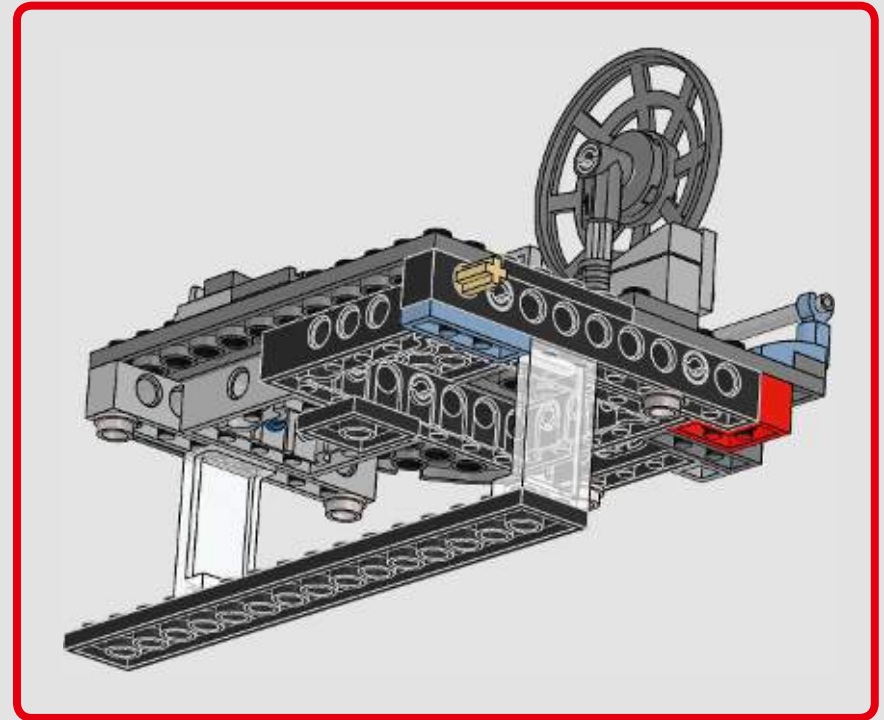
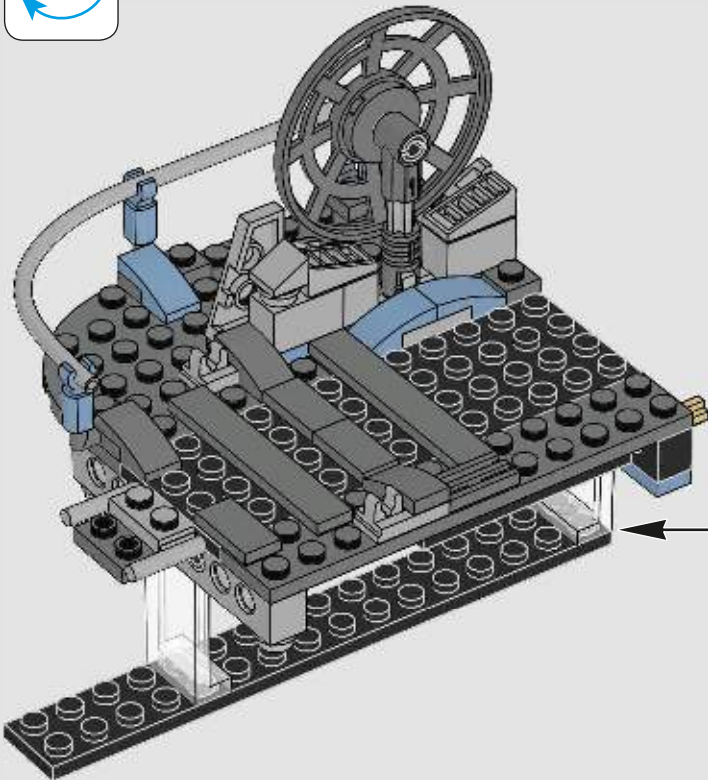
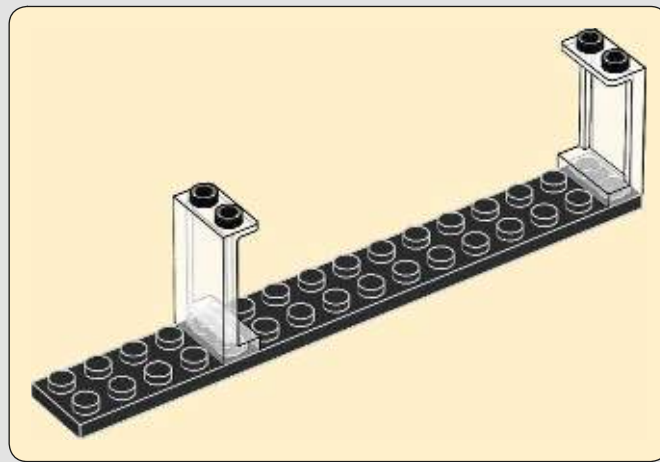

299

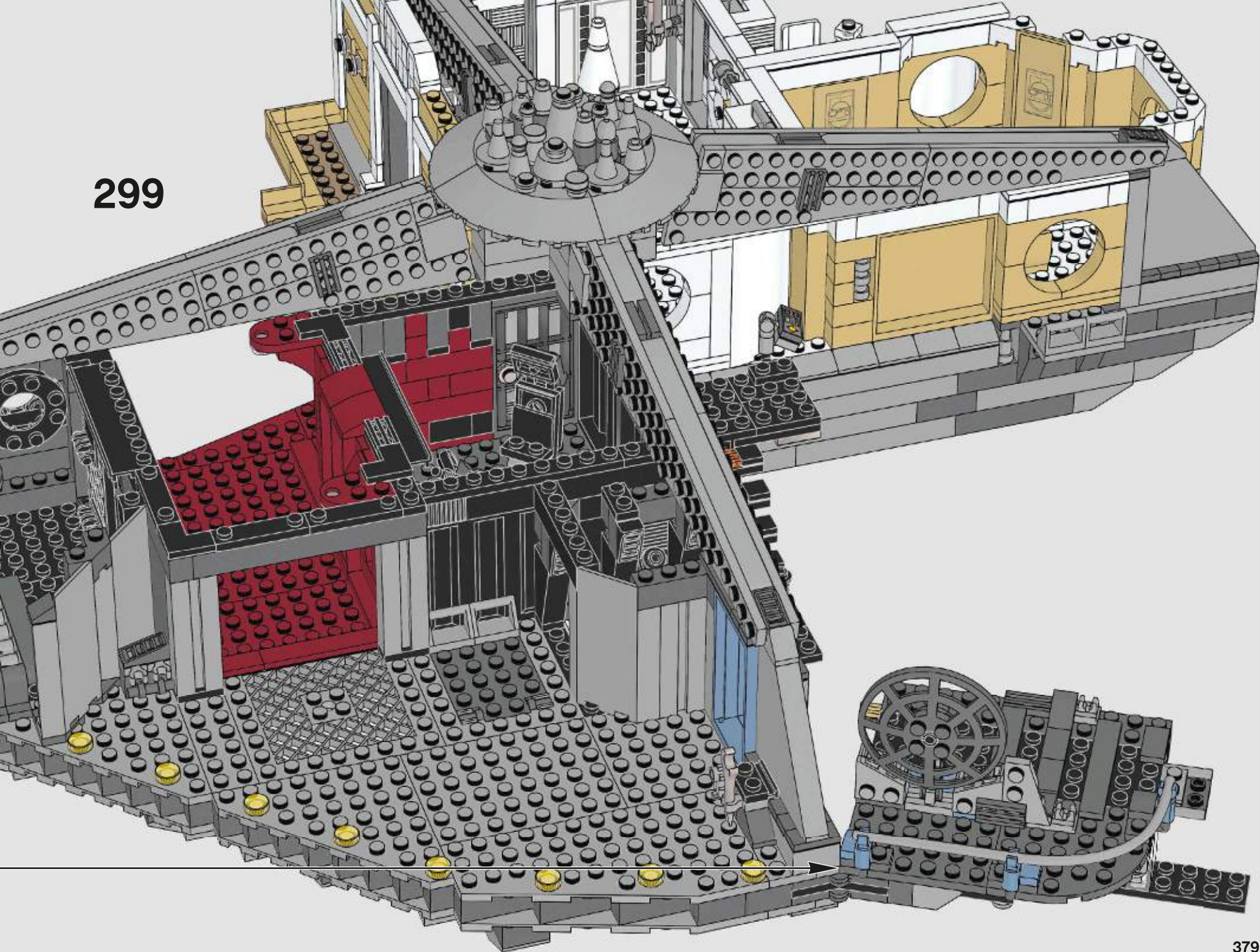

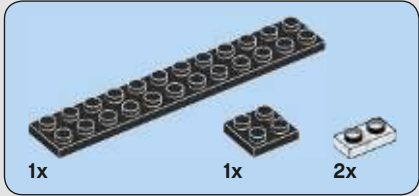
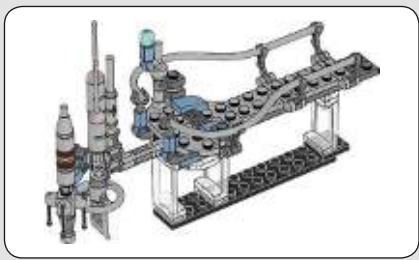

300

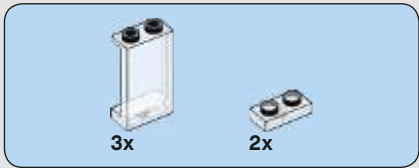
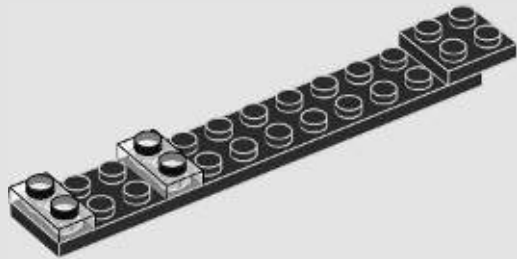

301

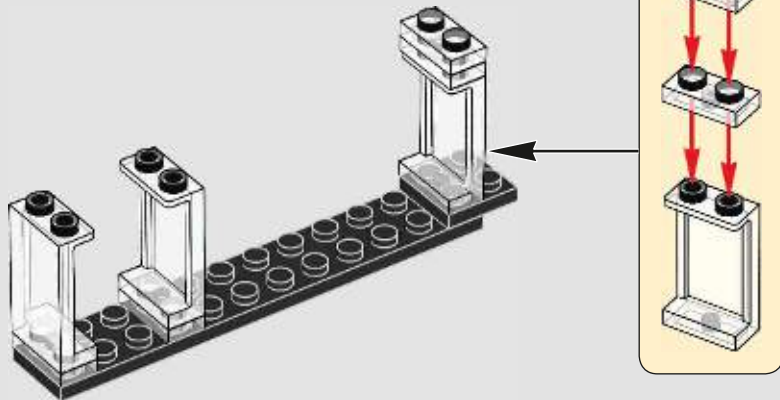

302



303

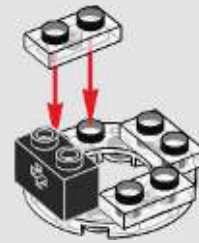

304





305

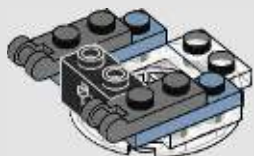

306

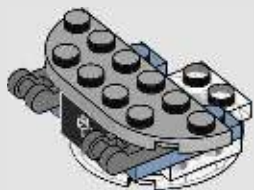

307

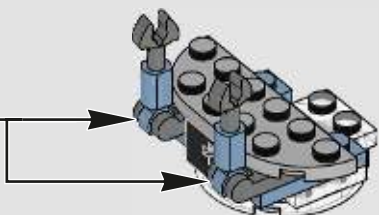
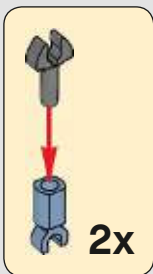

308

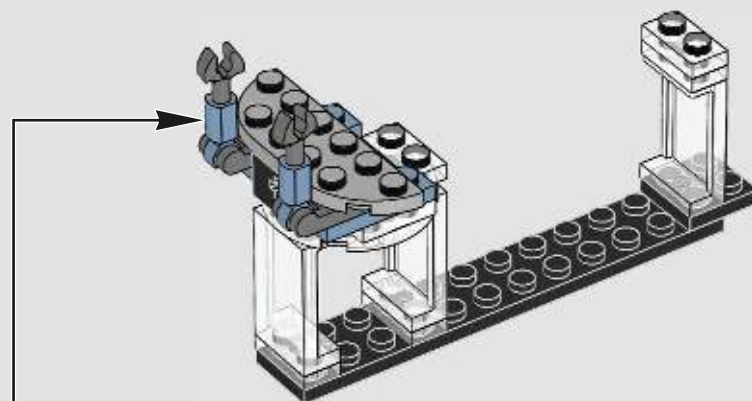

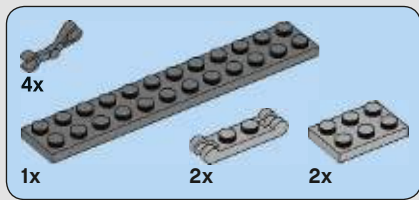

309

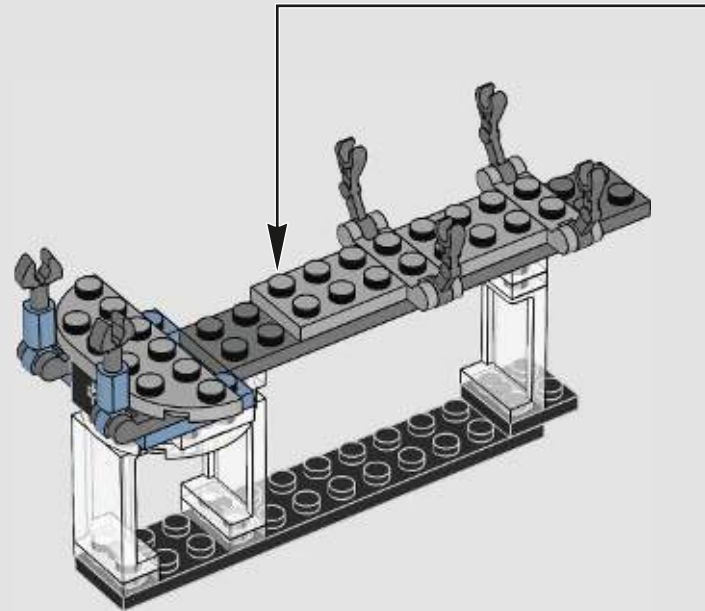
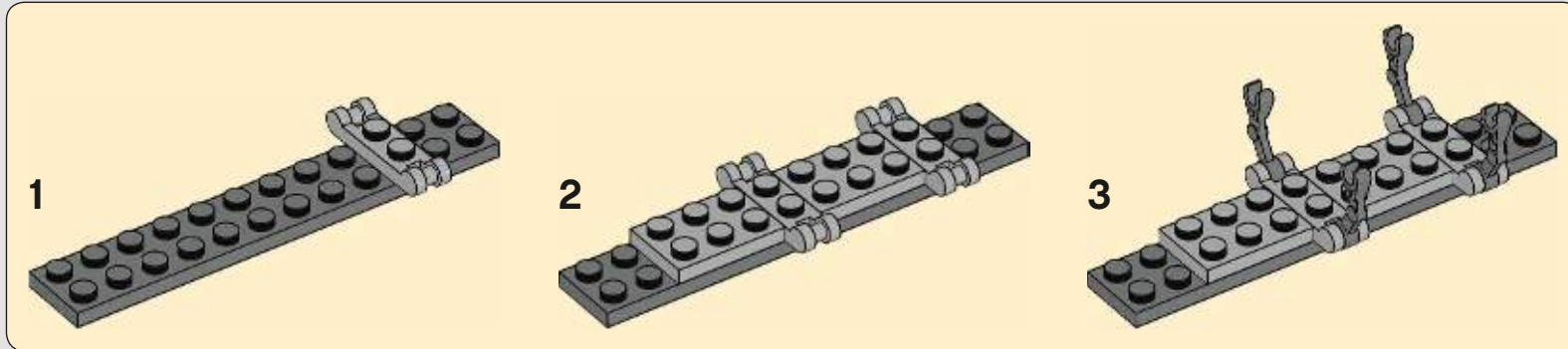

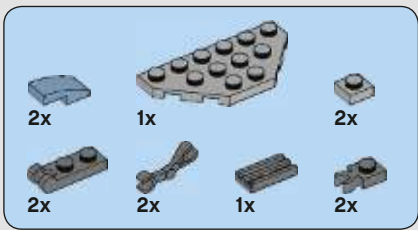

310

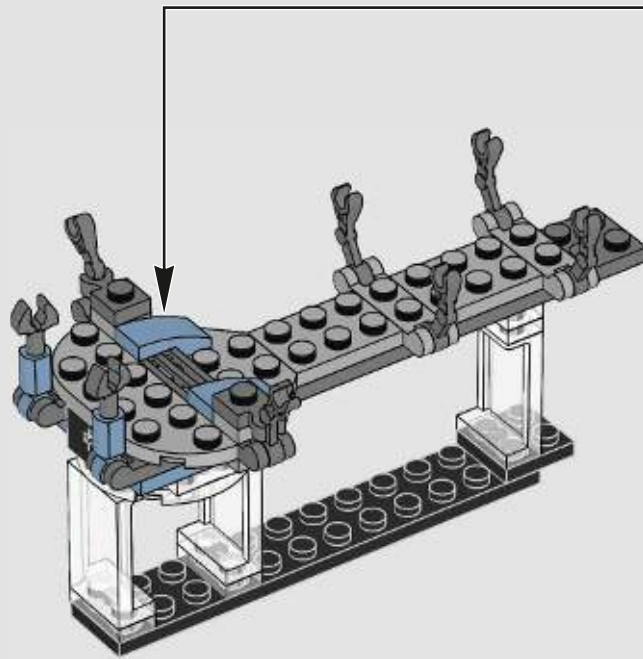
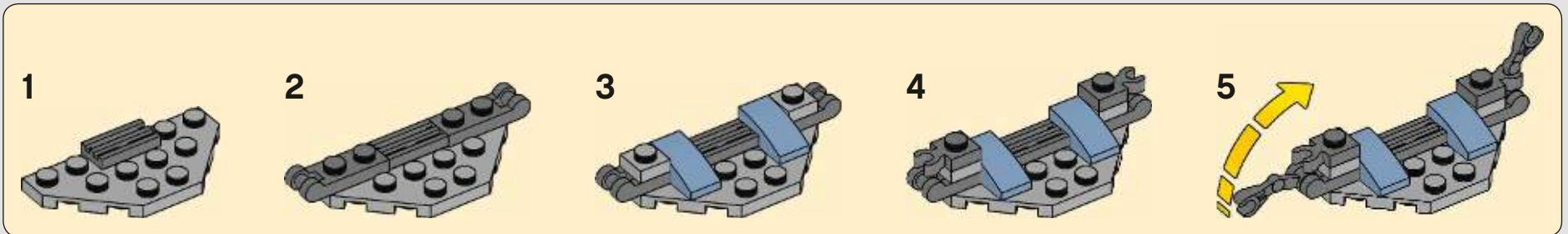



311

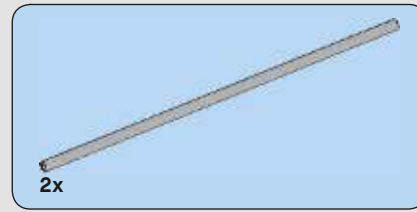
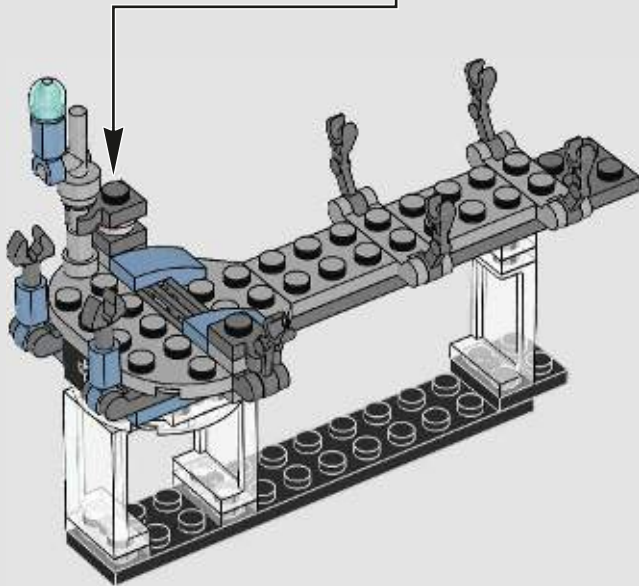
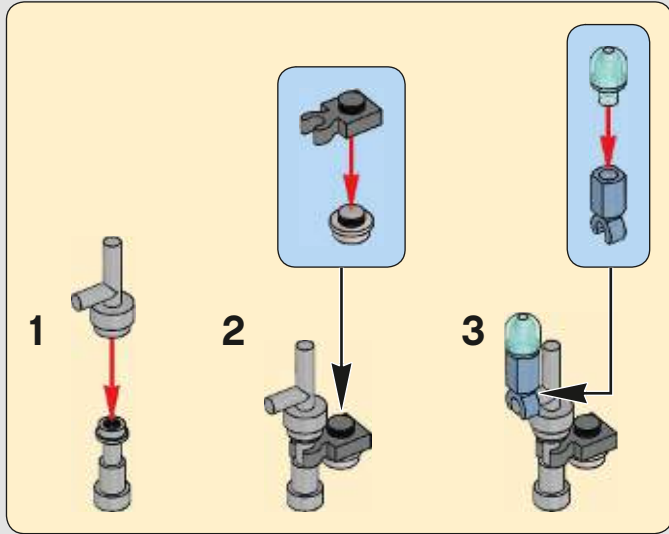

312

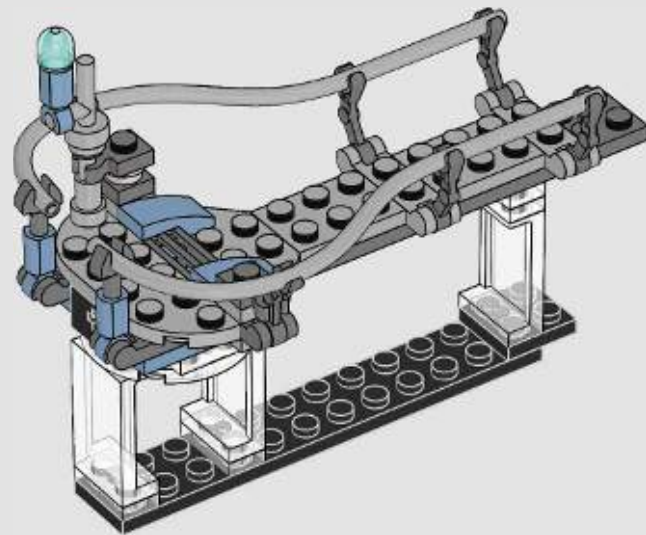

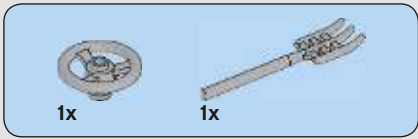
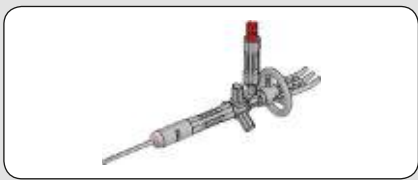

313

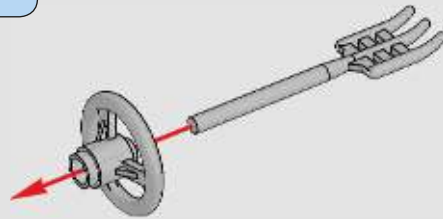

314

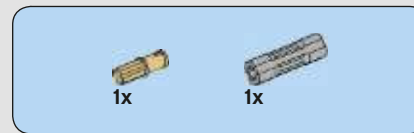
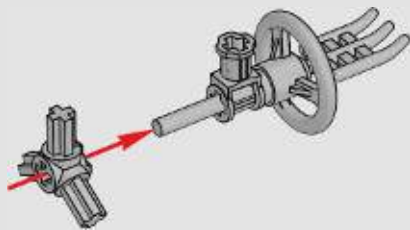

315

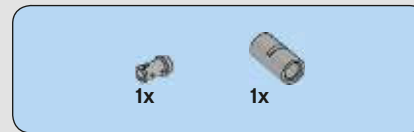
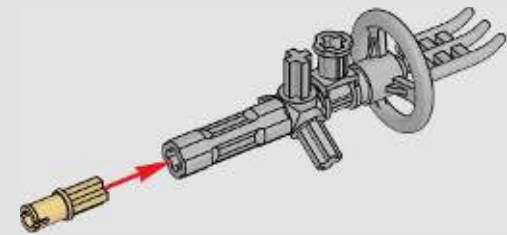

316

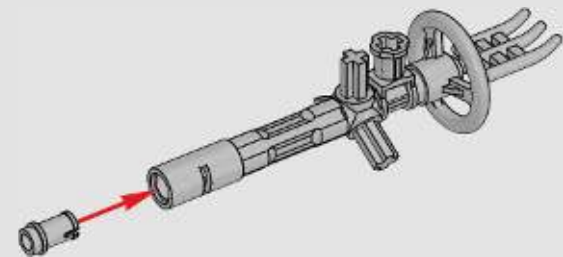



317

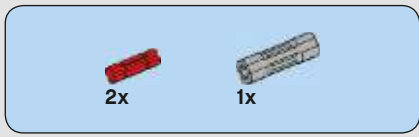
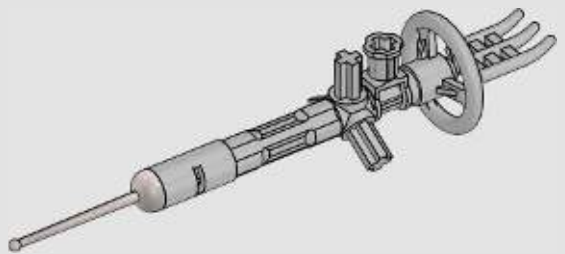

318

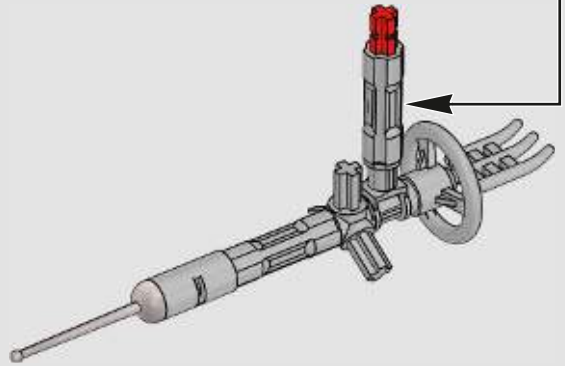
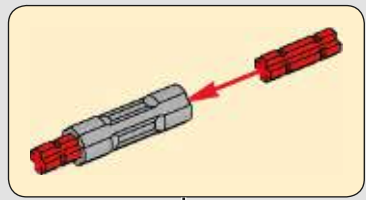

319

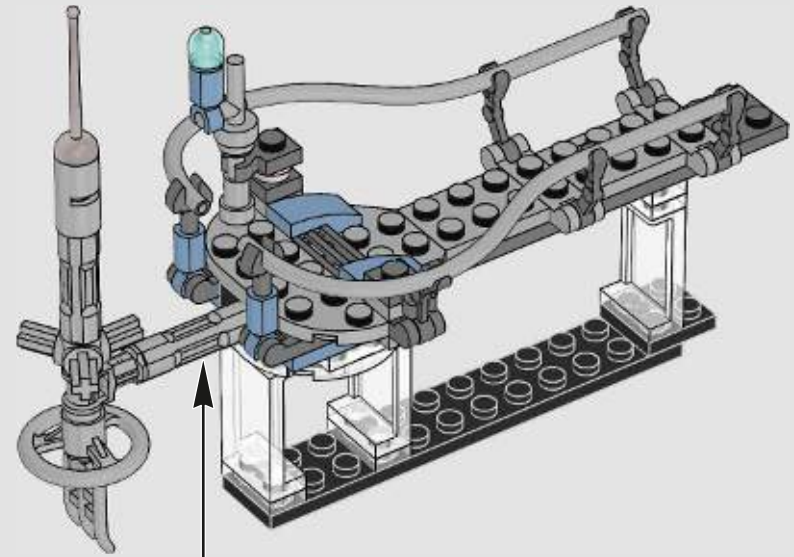

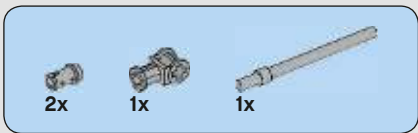

320

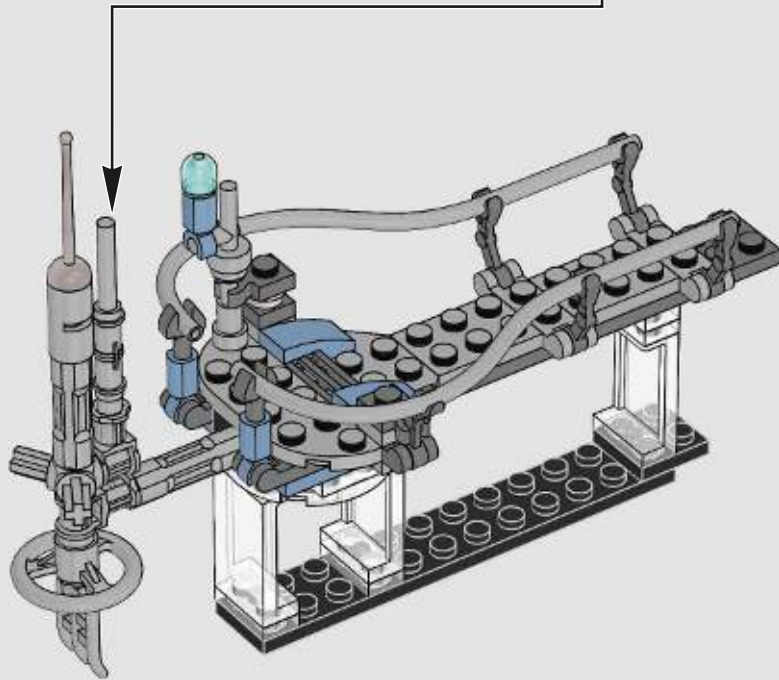
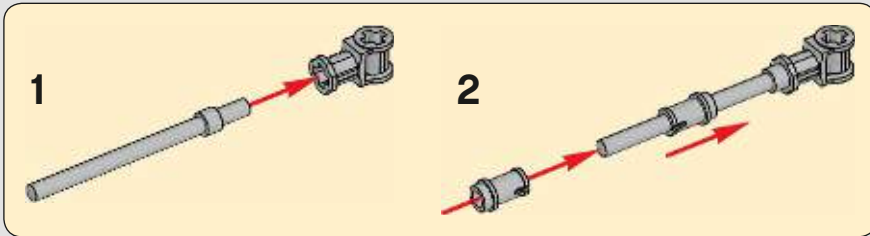

321

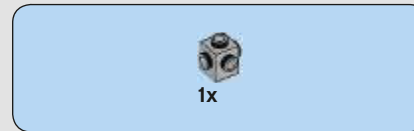
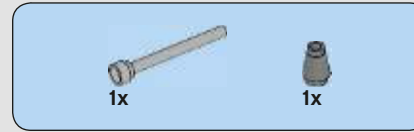

322

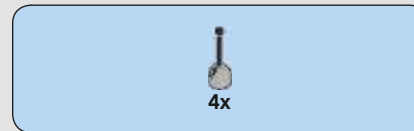

323





324

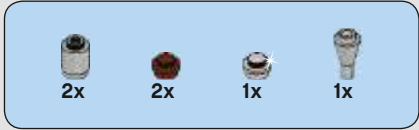
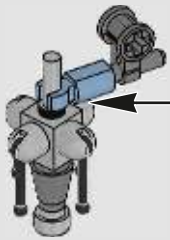
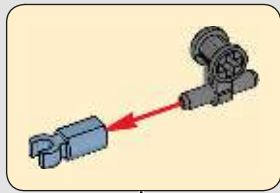

325

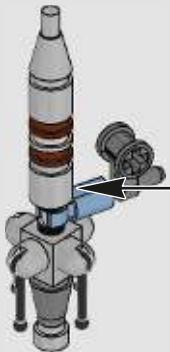
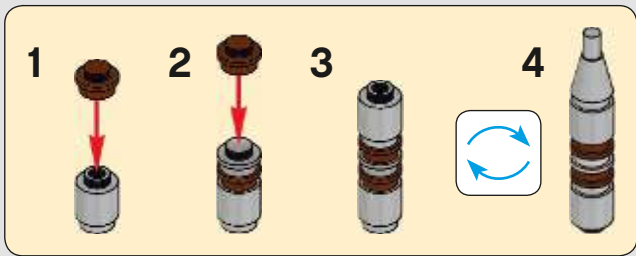

326

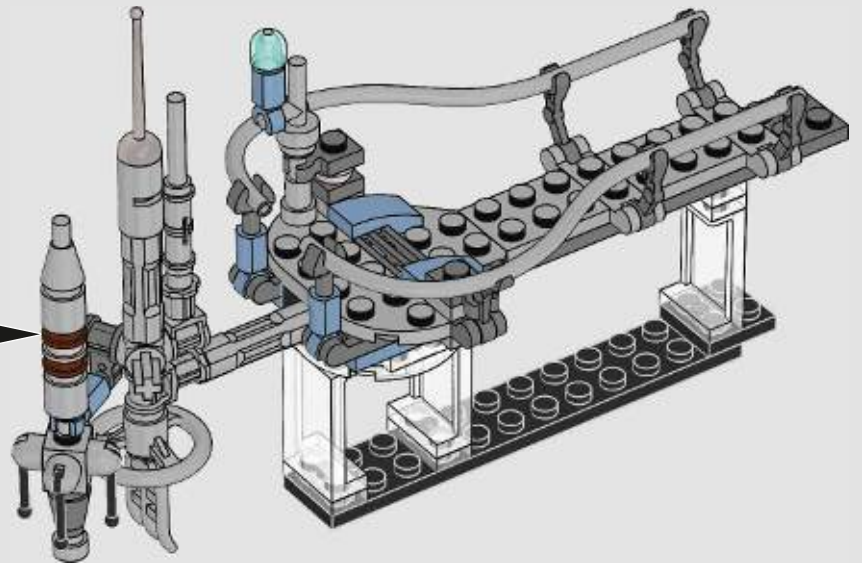



327

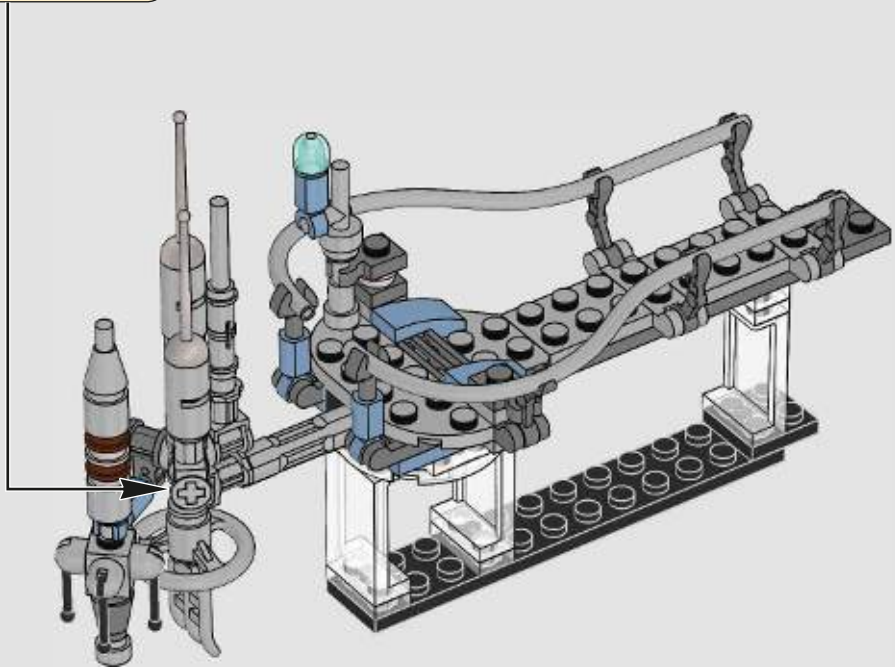
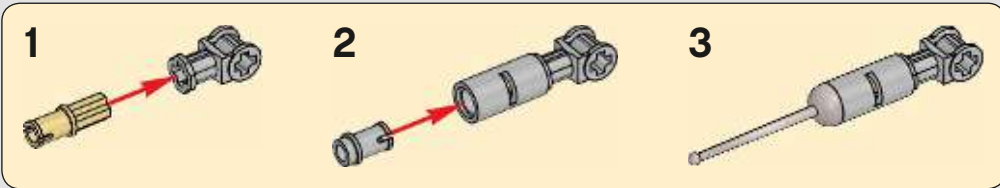

328

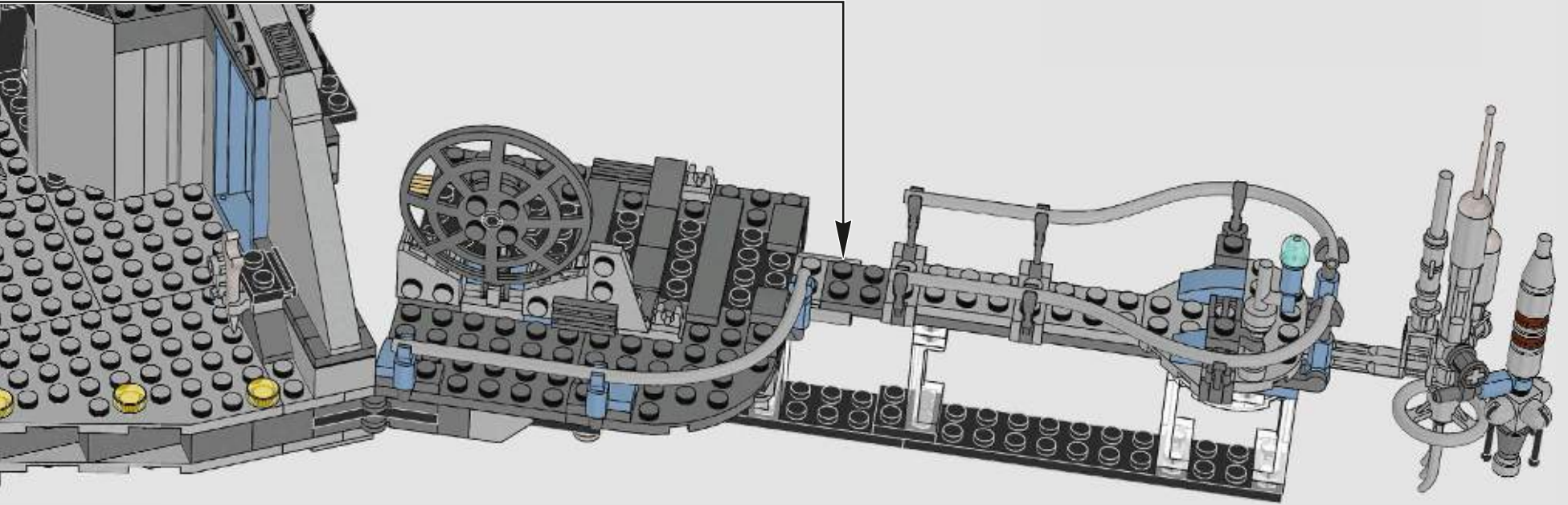
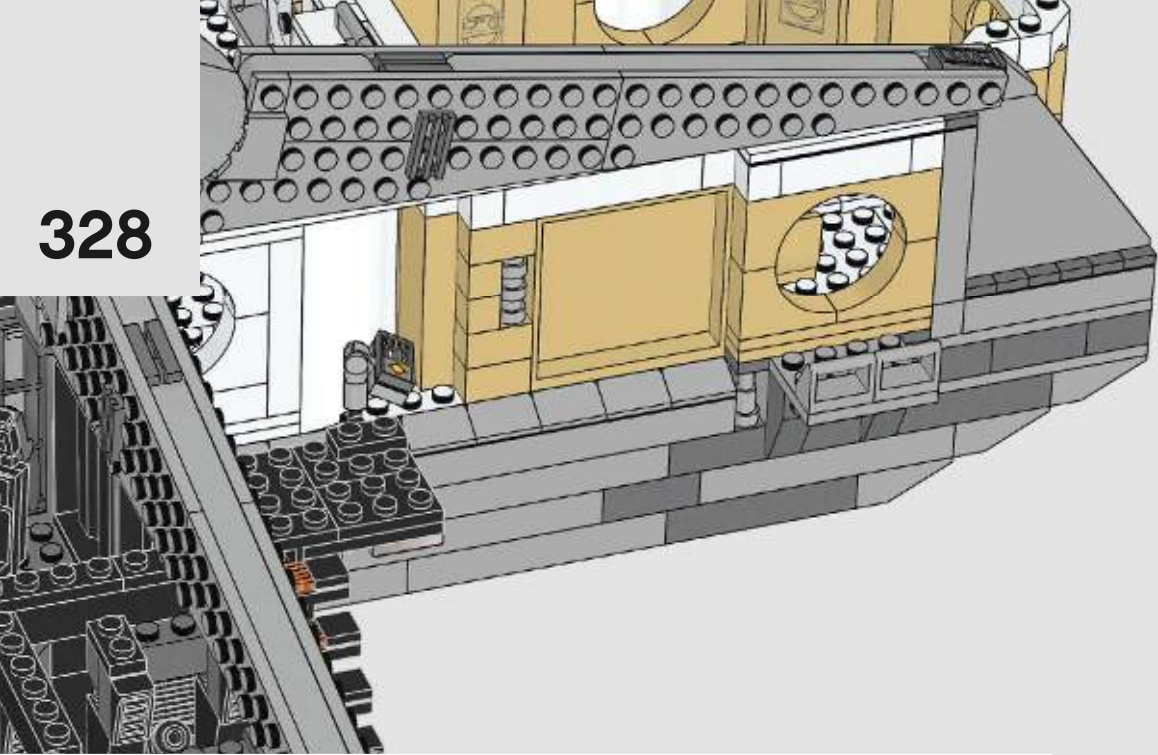

390

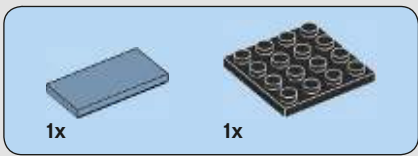

329

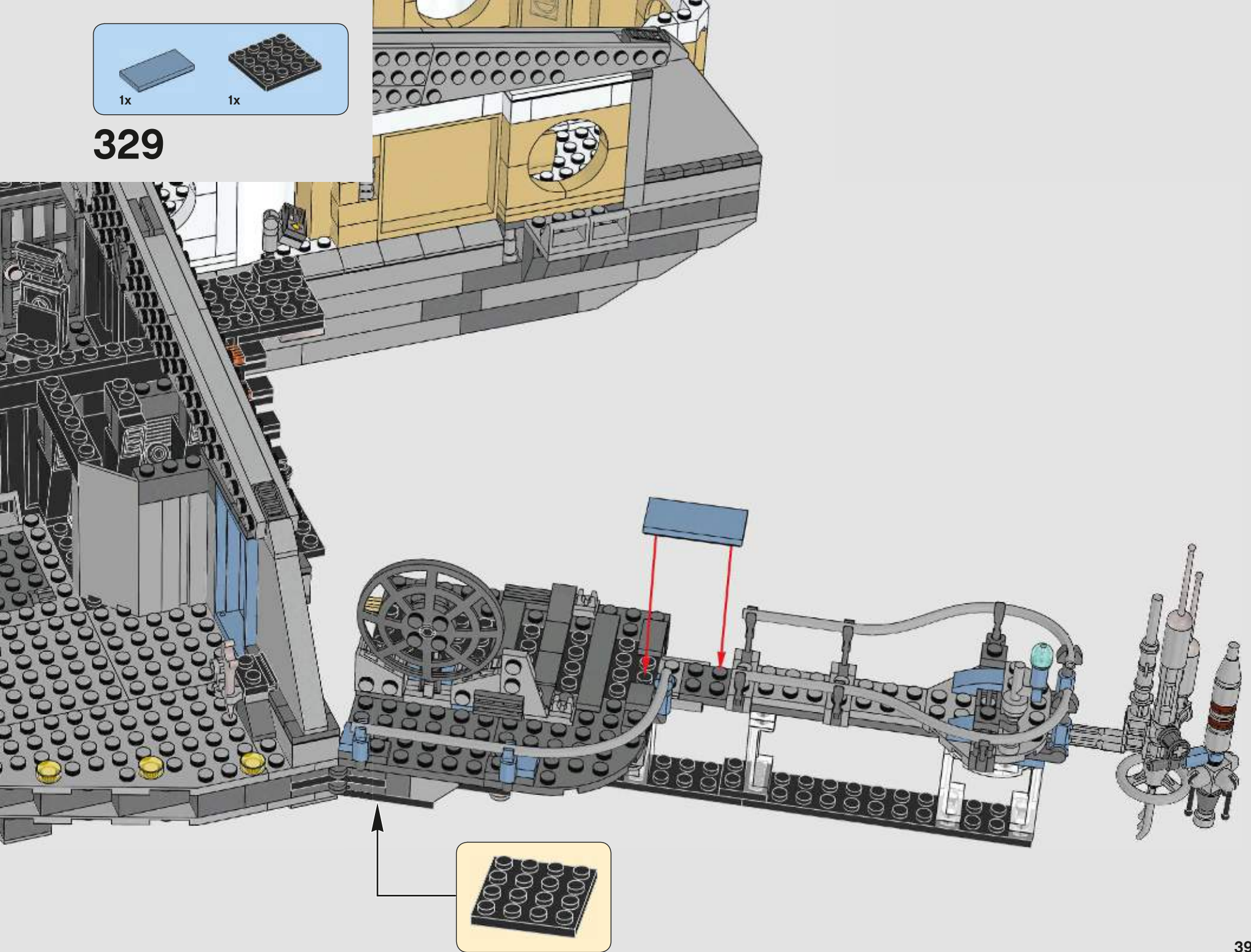

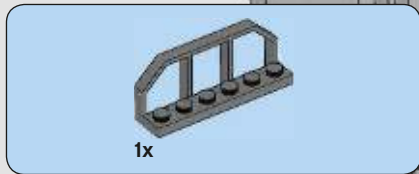

330

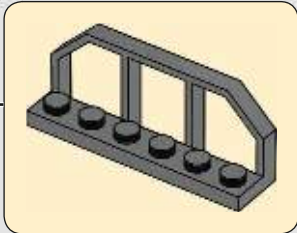
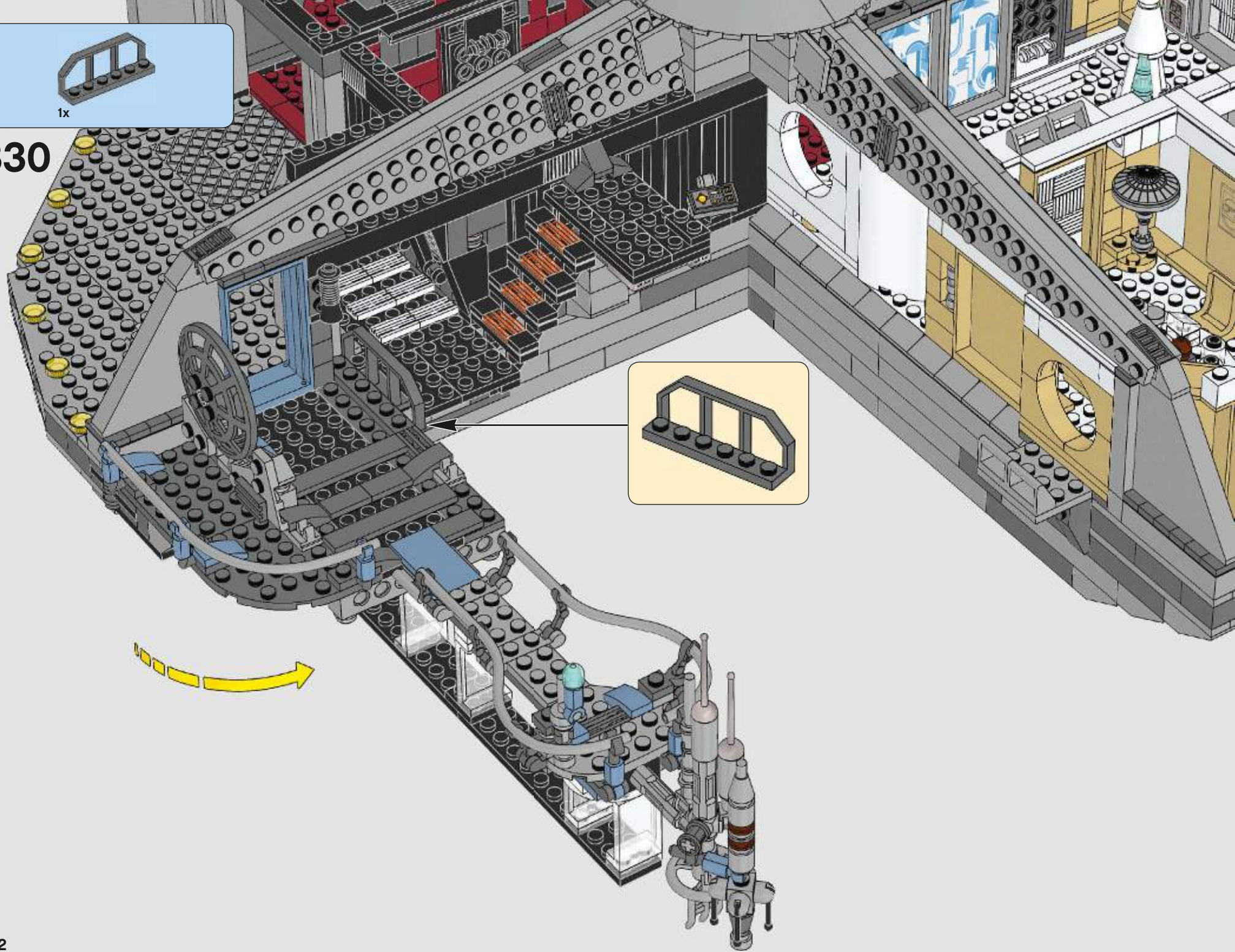

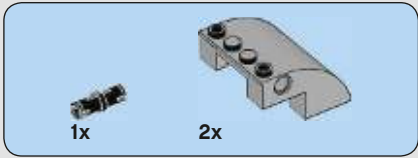
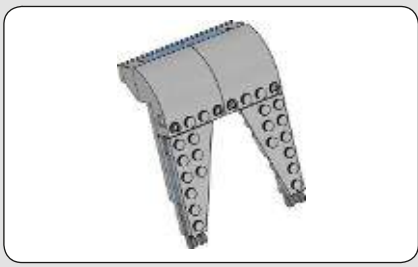

331

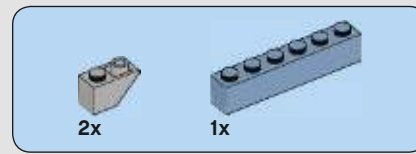
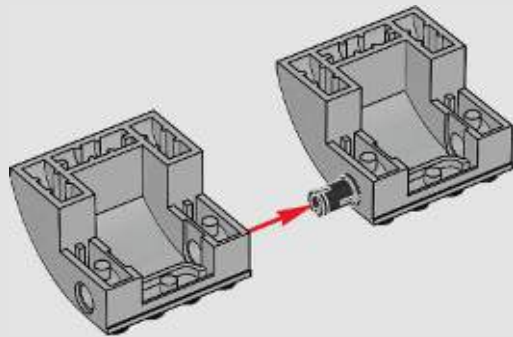

332

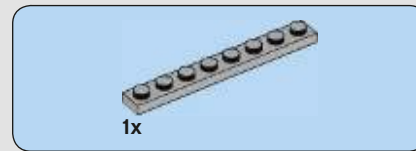
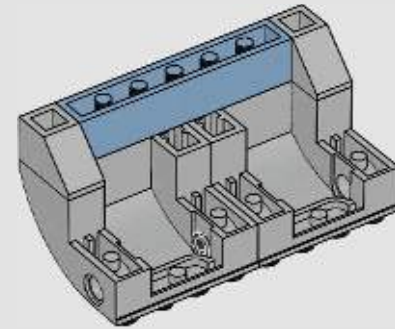

333

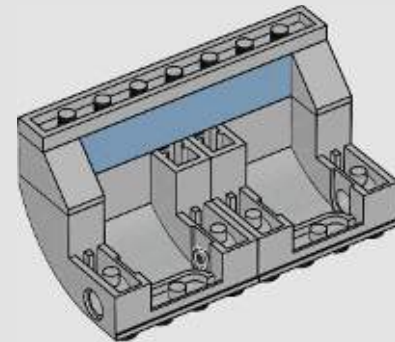

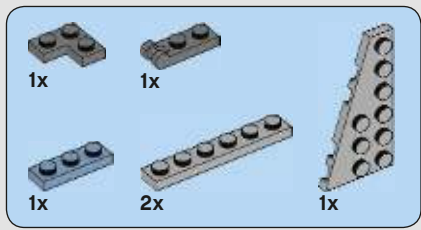

334

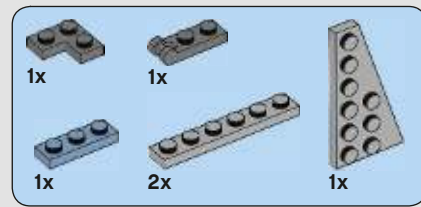
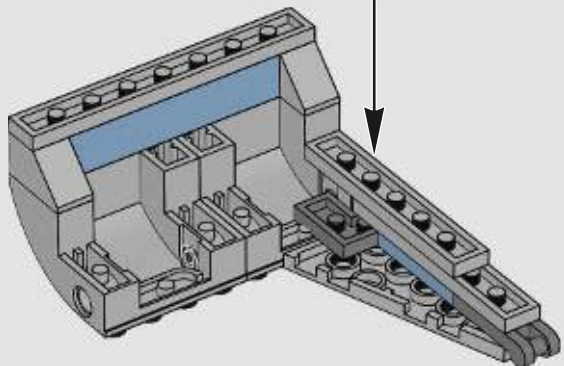
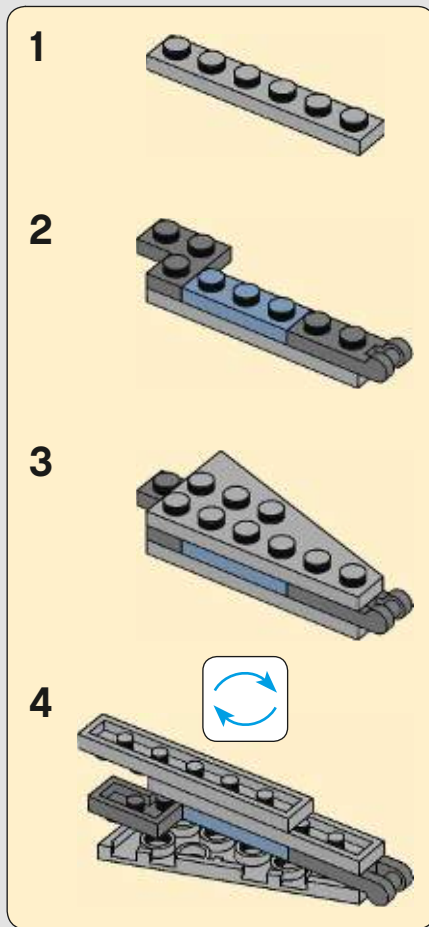

335

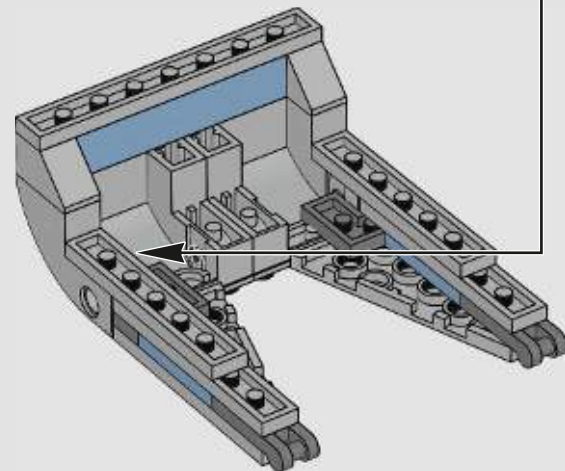
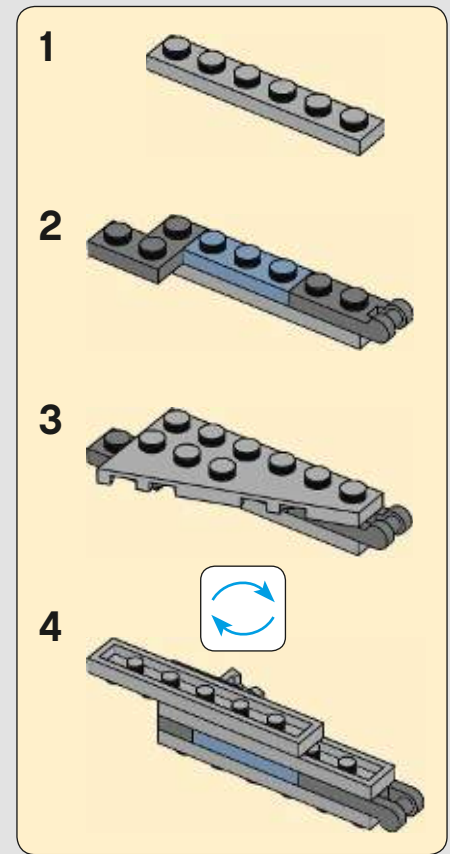

336

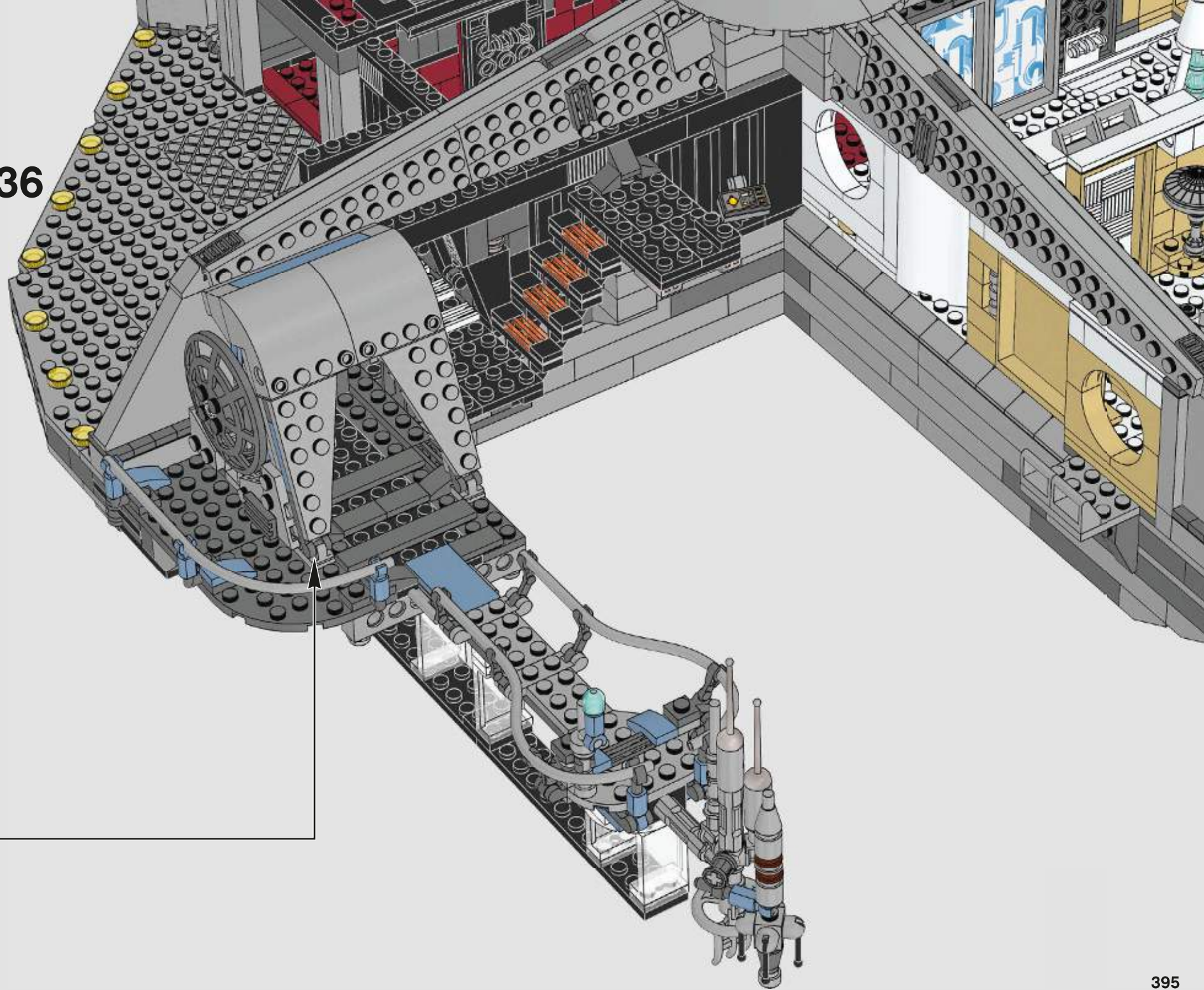

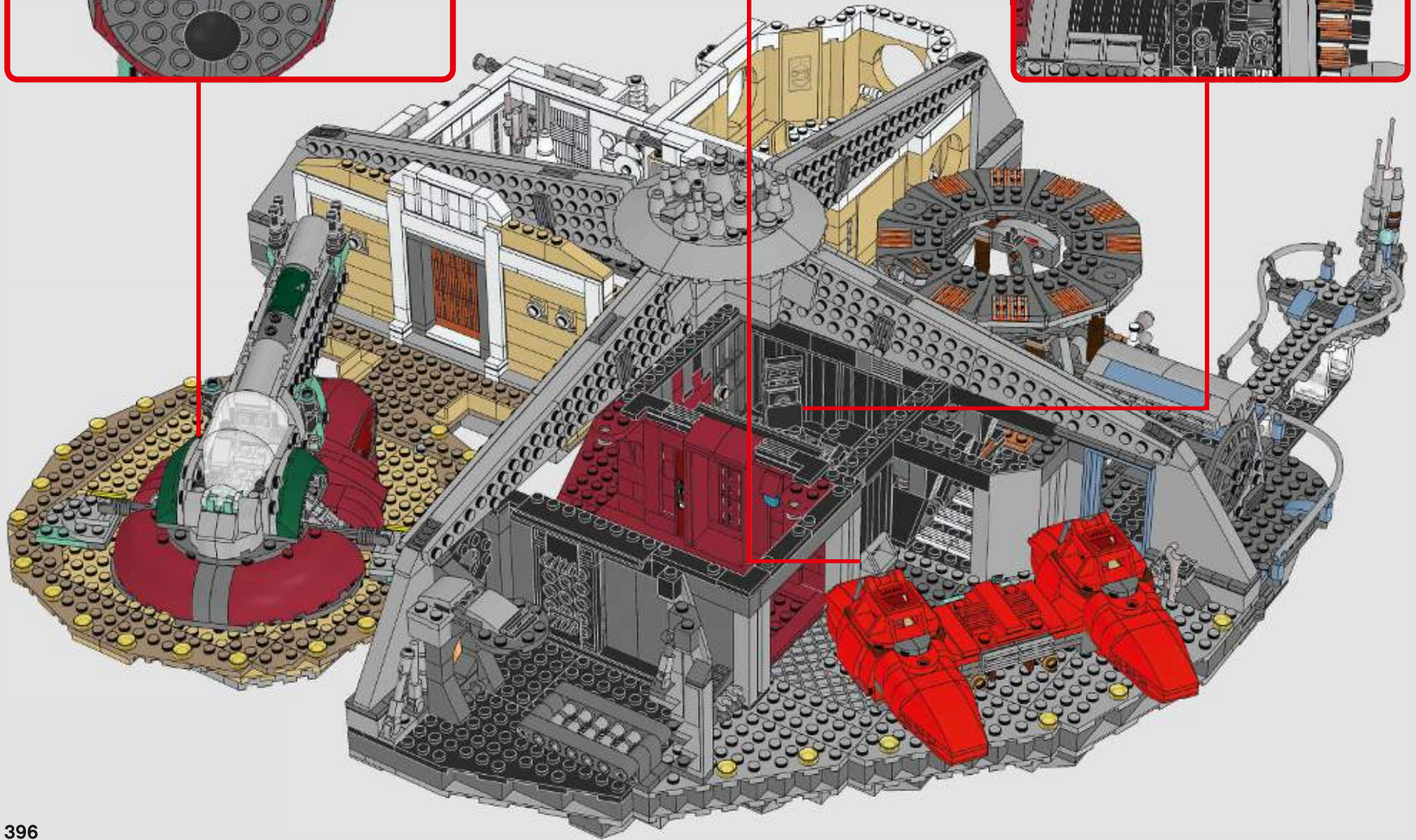
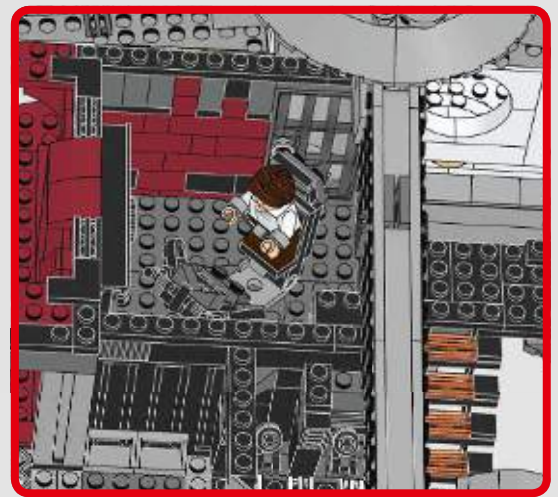
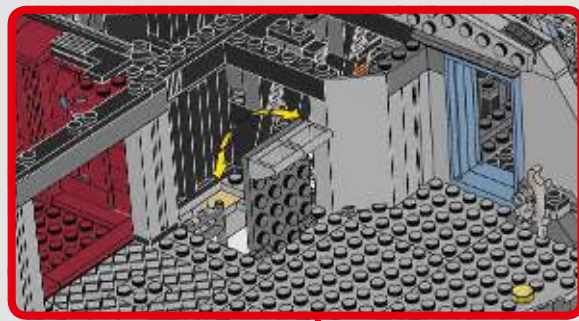
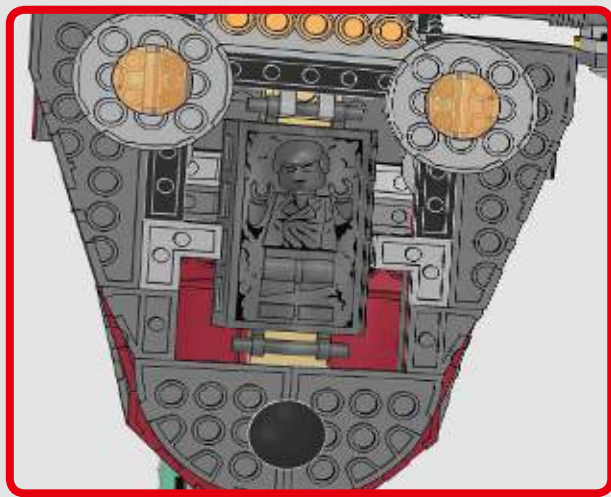



- 4x 6052824
- 1x 306201
- 1x 4518400
- 2x 4646844
- 4x 614101
- 1x 6114015
- 1x 459901
- 6x 302401
- 6x 6172366
- 6x 654101
- 4x 245301
- 4x 307001
- 1x 6055541
- 6x 300501
- 2x 4161326
- 1x 6044601
- 2x 4160857
- 1x 6055181
- 4x 6093053
- 2x 6080506
- 2x 6080520
- 22x 287701
- 2x 9327
- 1x 6195524
- 6x 3200001
- 1x 4515337
- 7x 4264360
- 6x 241201
- 2x 6166894
- 6x 306901
- 5x 245401
- 2x 4124113
- 9x 6137926
- 1x 6238641
- 6x 6093526
- 1x 4613762
- 2x 242001
- 12x 302201
- 5x 6058329
- 1x 6168612
- 7x 6172674
- 14x 300301
- 2x 4612342
- 2x 4515364
- 1x 362201
- 2x 4124113
- 2x 407901
- 4x 362301
- 2x 6110019
- 6x 4558168
- 1x 6195451
- 2x 6116218
- 2x 6238308
- 1x 6246885
- 1x 6009016
- 2x 4597131
- 2x 407901
- 4x 362301
- 2x 6110019
- 6x 4558168
- 1x 6195451
- 2x 6116218
- 2x 6238308
- 1x 6246885
- 1x 6009016
- 2x 4597131
- 9x 371001
- 5x 4143254
- 2x 243101
- 6x 301001
- 1x 303701
- 3x 300101
- 1x 4141476
- 1x 6192352
- 4x 300901
- 8x 663601
- 2x 366601
- 1x 6106183
- 1x 4513990
- 8x 416201
- 1x 303201
- 2x 4500878
- 2x 4144012
- 6x 303601
- 2x 4514842
- 2x 4585737
- 3x 6030980
- 4x 418793
- 10x 4159553
- 4x 4125253
- 6x 4113915
- 4x 4612603
- 12x 6232135
- 3x 4112980
- 4x 4278422
- 3x 4140562
- 5x 4666579
- 7x 4109995
- 6x 6146221
- 3x 4114026
- 26x 4113917
- 5x 4114064
- 1x 6046924
- 1x 4655257
- 7x 4114077
- 5x 4124455
- 1x 4118866
- 4x 6219785
- 6x 6212038
- 2x 6238693
- 2x 6056277
- 12x 4118790
- 4x 6213676
- 3x 4113916
- 2x 6058091
- 2x 4578110
- 2x 4124067
- 3x 6106187
- 11x 4112982
- 5x 4157277
- 2x 4512688
- 4x 4243824
- 4x 6034852
- 2x 4114324
- 1x 4114001
- 7x 6037398
- 4x 4509897
- 3x 4624185

8x 6170390
4x 6030266
2x 4142865
4x 6053011
4x 6092565
8x 6186398
4x 241221
4x 4597713
12x 6184782
4x 370021
2x 306921
6x 6029946
6x 243221
2x 6011814
2x 4140585
8x 6105976
1x 235721
2x 362321

4x 4251162
6x 4188189
1x 6129995
3x 243121
10x 302021
2x 6179656
2x 4561034
2x 6074878
2x 6096487
1x 383221
80x 4143005
2x 6086654
2x 9341
5x 4514553
2x 300223

4

1x 407024
2x 241224
5x 4598897
4x 4221775
1x 6056234
4x 6168646
4x 459926
4x 4558954
10x 307026
13x 302426
2x 6065496
1x 6122096
2x 4609050
1x 6112162
2x 6210270
2x 4535765
4x 6157554
4x 6196548

2x 4537551
1x 4659662
3x 4278359
12x 4253815
29x 4121715
1x 4596914
1x 9339
1x 6080486
1x 6112160
4x 287726
2x 4515340
3x 4636202
2x 6047276
10x 241226
1x 6178922
18x 302326
1x 4598528

3x 4541191
4x 6138173
2x 370026
1x 245426
1x 4614788
2x 4569733
1x 434926
1x 6020193
5x 6000650
3x 4556158
6x 4107761
4x 4498713
4x 4107828
3x 4248204
2x 306826
11x 302226

1x 6192346
4x 6211476
8x 6166859
6x 4124096
4x 6133722
1x 4119589
1x 235726
2x 4183060
1x 4107765
4x 6102734
9x 362326
3x 362226
2x 6080519
1x 6077866
1x 400626
1x 6117858

8x 302126
1x 329826
7x 4599499
1x 370126
2x 6045912
1x 4498712
2x 4297713
2x 4560182
4x 302026
1x 6138217
3x 241926
4x 366626
1x 4143181

3x 300926
3x 6128857
3x 4243819
2x 6058118
1x 4517986
1x 6117766
1x 379526
2x 303226
1x 4279270
4x 6161298
2x 373726

10

7x 447726
2x 273026
3x 303626
1x 4188143
3x 4514845
2x 389526
1x 611226
1x 244526
1x 302926
1x 428226

- 4x 6208450
- 1x 6252042
- 1x 4124108
- 1x 6081343
- 4x 6240225
- 3x 6139460
- 1x 4124073
- 1x 6252049
- 3x 6223655
- 10x 6240030
- 1x 6245250
- 12x 6252041
- 5x 6211814
- 7x 6240204
- 1x 6018931
- 1x 6245241
- 1x 6087930
- 7x 6174945
- 6x 6179812
- 6x 6142245
- 2x 6138708
- 1x 6124349
- 1x 6220992
- 1x 6055172
- 1x 6222455
- 1x 6223052
- 12x 6228921
- 4x 6028018
- 4x 4616279
- 4x 6167615
- 1x 4153826
- 2x 4121741
- 1x 6240515
- 4x 6028022
- 4x 4541618
- 2x 6031821
- 1x 6124940
- 3x 4246957
- 1x 4530712
- 2x 4251796
- 2x 6246855
- 1x 6023481
- 1x 4584809
- 4x 4625236
- 4x 6080431
- 6x 6069257
- 2x 6187611
- 3x 4531415
- 2x 4550169
- 12x 4541376
- 2x 6083977
- 8x 4539102
- 6x 4541506
- 8x 4539090
- 28x 4539097
- 2x 6173168
- 1x 4539069
- 2x 4539068
- 2x 6107758
- 3x 4583299
- 4x 6028713
- 4x 6228924
- 2x 4568753
- 4x 4539060
- 4x 4539061
- 6x 6042953
- 8x 6052777
- 2x 4539064
- 2x 6080435
- 1x 6228925
- 1x 6192350
- 12x 4650865
- 1x 4618986
- 1x 6035700
- 1x 6035709
- 1x 6028115
- 2x 6186106
- 21x 6240227
- 2x 4278409
- 1x 6251286
- 1x 6240234
- 1x 4211183
- 1x 6060731
- 2x 4216581
- 1x 6177571
- 2x 6159776
- 4x 4211559
- 6x 6092590
- 4x 6135494
- 1x 6238689
- 6x 6123759
- 2x 6199163
- 1x 4539481
- 2x 6212288
- 4x 6152107
- 8x 4211412
- 8x 4529241
- 1x 4640844
- 5x 6167667
- 3x 6168647
- 7x 4650260
- 7x 4211525
- 1x 4211573
- 2x 6250597
- 4x 4211503
- 4x 4211483
- 4x 4558953
- 2x 4211399
- 8x 4211622
- 3x 4521921
- 2x 4211389
- 4x 4211415
- 2x 4215513
- 1x 4211362
- 1x 4595836
- 1x 4211511
- 1x 4211375
- 1x 6163477
- 1x 6163478
- 3x 4535764
- 4x 4594238
- 2x 4211791
- 1x 4211794
- 2x 4514195
- 4x 6173127
- 5x 4278273
- 2x 6028324
- 12x 4568637
- 4x 6179186
- 1x 6057616
- 12x 4211807
- 5x 4211553
- 1x 4227657
- 2x 6004888
- 5x 6028812
- 8x 6093859
- 11x 4211350
- 11x 4211357
- 4x 4211388
- 10x 4211398
- 3x 4211437
- 3x 4598526
- 2x 4211519
- 2x 6092111
- 3x 6015344
- 5x 4211363
- 4x 4582153
- 4x 6123809
- 7x 4657366
- 3x 4556157
- 9x 4211644
- 2x 4550251
- 1x 4502595

1x 4641048
4x 4535738
1x 6093527
1x 4282786
1x 4282789
10x 4208988
10x 4209006
16x 4211353
12x 4211413
2x 6102357
7x 4666449

2x 6212077
2x 6163990
4x 4211349
1x 4211410
4x 4567448
1x 4211815
6x 4654577
1x 4520320
1x 6187170
2x 4225033
3x 6196757
1x 6070564
1x 4580510
6x 4211428
6x 6211969
2x 4251163

3

1x 6087590
2x 6093058
3x 4563698
6x 4507056
8x 4211396
26x 4211570
9x 4211386
1x 4211464
1x 6246886
4x 4296059
4x 4211610
1x 4211356
4x 4211394

6x 4211445
1x 4622803
6x 6064030
2x 6028015
2x 6015347
6x 4645412
3x 4211473
1x 4646512
16x 4211395
3x 4518653
7x 4211385
8x 6039346
2x 6081975

2x 4211617
6x 6028811
4x 4211616
3x 6105964
1x 6171067
6x 6132983
1x 4211352
4x 4211393
7x 4211438
3x 4211549

1x 4527174
2x 6195468
1x 4211640
5x 6038002
1x 4243797
4x 4160560
1x 6228920
1x 6015349
5x 4211795
2x 4211805
12x 4211452

7

3x 4211392
3x 4495930
11x 4211425
1x 4211481
1x 4211442
2x 4211406
56x 6037399
3x 4211474
4x 6063878
1x 4251149
2x 4211521

7

8x 4211462
1x 6152230
9x 4211408
2x 4514846
1x 4211360
1x 6116263
6x 4268343
4x 4542577
3x 6112684
7x 4211486

15

1x 4179828
2x 4646861
30x 4650500
24x 6250159
4x 6056383
1x 6102986
2x 6135278
1x 6117971
12x 6228922
1x 6074893
9x 4211090
2x 4529240
1x 6188216
1x 4210633
4x 4289542
2x 6100030
3x 4210658
5x 6051334
17x 4211098

16x 4210719
7x 4504378
3x 6071226
4x 6199549
2x 4210690
2x 6025235
16x 6228923
1x 6020189
2x 4579354
1x 6143417
1x 6143423
1x 4521512
3x 4587212
1x 6186621
3x 4210695
2x 6152814
3x 6055313
2x 4516546

- 16x 4210636
- 2x 4210726
- 4x 4210763
- 2x 6164073
- 2x 4210892
- 3x 6029948
- 17x 4211063
- 7x 4210900
- 34x 6092572
- 1x 4211039
- 5x 4211052
- 10x 4211088
- 2x 6019987
- 1x 4221879
- 2x 6013658
- 21x 4210631
- 13x 4540386
- 3x 4611703
- 3x 4211135
- 3x 4211075
- 1x 6186622
- 7x 4624186
- 4x 6000606
- 2x 4543086
- 2x 4211128
- 12x 6146321
- 1x 4211055
- 1x 4529727
- 1x 4529728
- 8x 4211094
- 3x 4210635
- 3x 6047417
- 4x 6177079
- 1x 4211000
- 1x 4211054
- 1x 4211093
- 22x 4211109
- 2x 6015356
- 10x 4521187
- 1x 4211060
- 2x 4524930
- 2x 4618881
- 18x 4211104
- 1x 4568734
- 3x 4211045
- 2x 4225733
- 1x 4521886
- 21x 4211043
- 1x 4263176
- 2x 4211064
- 21x 4211105
- 2x 6099909
- 4x 4210667
- 4x 4210725
- 5x 4211001
- 1x 4210999
- 2x 4213607
- 2x 4211053
- 6x 4211103
- 2x 4598769
- 2x 4535833
- 2x 4528323
- 1x 6039176
- 14x 6102774
- 1x 4560184
- 4x 4211065
- 1x 6005668
- 2x 4210686
- 6x 4508553
- 6x 4211085
- 12x 4561036
- 2x 4210651
- 1x 4505068
- 1x 6063685
- 2x 4243831
- 6x 4222042
- 4x 4210728
- 2x 6112207
- 1x 4224253
- 1x 6063681
- 14x 4210875
- 2x 4495931
- 2x 4521572
- 1x 4595710
- 1x 4210998
- 2x 4211008
- 2x 4211099
- 3x 4211115
- 1x 4210997
- 2x 4645730
- 2x 4211134
- 1x 4500517
- 5x 4211107
- 2x 4210794
- 3x 4210678
- 1x 6004908
- 2x 6133611
- 6x 4211067
- 8x 6000970
- 2x 4256149
- 1x 6037634
- 1x 6034982
- 4x 6211448
- 1x 6058788
- 1x 4529672
- 2x 4632767
- 1x 6238640
- 1x 6063675
- 1x 6063666
- 1x 6195431
- 1x 6238688
- 1x 6238643
- 1x 6238691
- 2x 6087541
- 1x 6238687
- 1x 4584819
- 1x 4653753
- 1x 6078373
- 1x 6138412
- 2x 6051389
- 6x 6162578
- 5x 6121350
- 2x 6058160
- 21x 4633691
- 2x 6124928
- 1x 6150296
- 11x 4619636
- 1x 6167576
- 2x 4618270
- 3x 6021888
- 2x 6238724
- 1x 6238725
- 2x 6112518
- 1x 6058705
- 1x 6129051
- 1x 6178684
- 1x 6118815
- 1x 6238339
- 1x 6238307

9







5



5.5

7



Customer Service
Kundenservice
Service Consommateurs
Servicio Al Consumidor
LEGO.com/service or dial

00800 5346 5555 :       

1-800-422-5346 :  

WIN

GO TO WWW.LEGO.COM/PRODUCTFEEDBACK AND GIVE US YOUR SHORT **FEEDBACK** ABOUT THIS LEGO® SET FOR A CHANCE TO WIN A COOL LEGO PRIZE.

Terms & Conditions apply

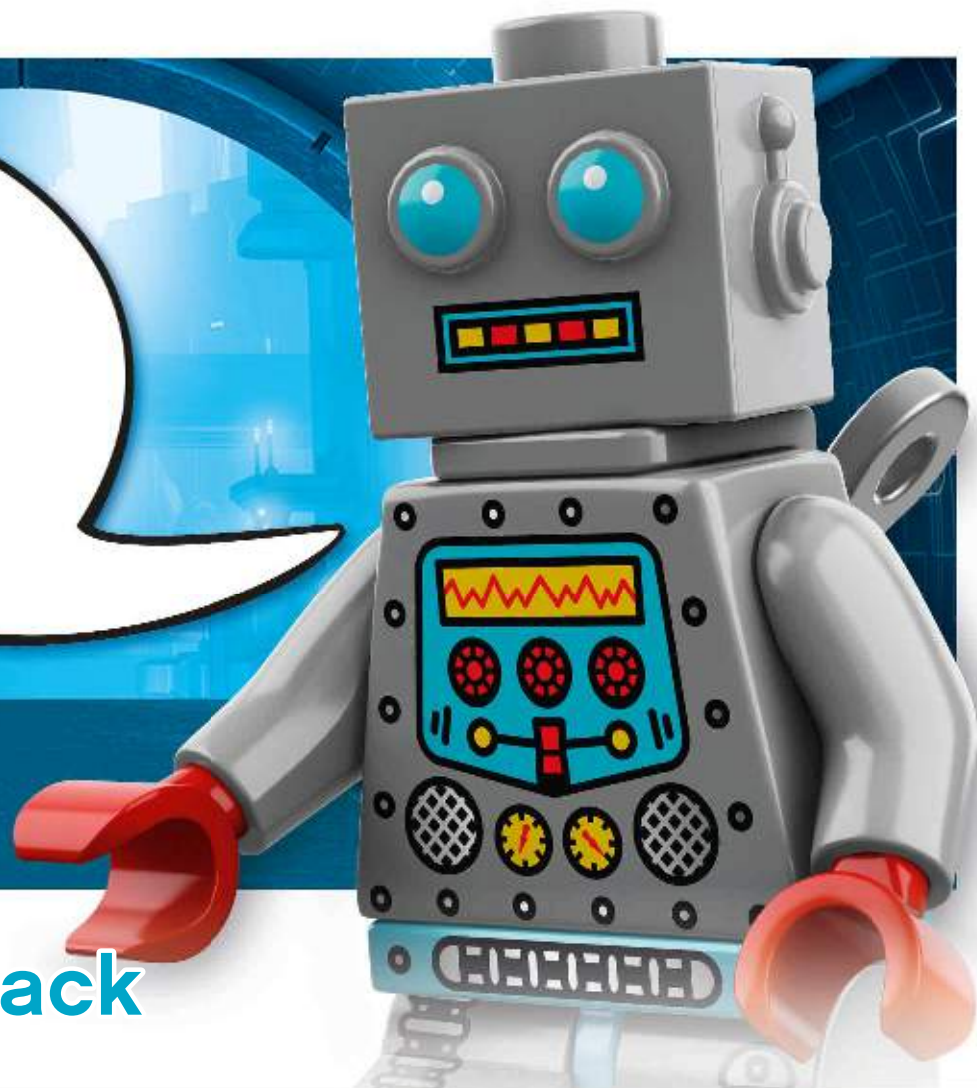

LEGO.com/productfeedback

GEWINNE

Erzähle uns auf www.LEGO.com/productfeedback

etwas über die Erfahrungen, die du mit diesem LEGO® Set gemacht hast, und sichere dir die Chance auf einen coolen LEGO Preis!

Es gelten die Teilnahmebedingungen

GAGNE

Rends-toi sur www.LEGO.com/productfeedback

et donne-nous quelques commentaires sur ce produit LEGO® pour avoir une chance de gagner un prix LEGO !

Voir Conditions Générales

GANAN

Visita www.LEGO.com/productfeedback

y envíanos tu opinión acerca de este set LEGO®. ¡Participarás en el sorteo de un premio LEGO!

Términos y Condiciones aplicables

获取奖品

登录 www.LEGO.com/productfeedback

给出关于此乐高®套装的简短反馈，就有机会获得炫酷乐高奖品

《条款及条件》适用

경품 당첨 기회

www.LEGO.com/productfeedback

페이지로 이동하여 이 레고® 세트에 대한 간략한 피드백을 보내 주시고 멋진 레고 경품을 탈 수 있는 기회도 잡으십시오

약관 적용

ЗАПОЛНИ АНКЕТУ И ПОЛУЧИ ПРИЗ

Перейди по ссылке www.LEGO.com/productfeedback

ответь всего на несколько вопросов об этом наборе LEGO®, и у тебя появится шанс выиграть замечательный приз от компании LEGO.

Применяются Условия и правила участия

